

## **General Class License Manual (GCLM) and Tech Q&A – Errata and Corrections**

The following material supports or corrects the following publications:

GCLM 9th edition – First Printing  
GCLM Q&A 6th edition – First Printing

Determine the version of the manual you are using by referring to the first page of the preface inside your copy. Look for the text box with the copyright information where you'll also find the edition and printing information. (If the edition number is not followed by printing information, the book is the first printing.) The ARRL wishes to thank readers who sent feedback about errors.

New items added in this version of the document are in **red**.

The current question pool for the General Class license took effect on July 1, 2019.

### **Question Pool Changes**

None

### **SUPPLEMENTAL INFORMATION**

#### *General Class License Manual*

Question G1E11 gives the correct answer as “(D) Anywhere in the 6 meter or shorter wavelength bands, and in limited segments of some of the HF bands”. The question assumes that “anywhere” refers to “anywhere RTTY and data emissions are permitted”. RTTY and data emissions are allowed on 6 meters from 50.1-54.0 MHz. (Note that Table 6.3 shows a range of 50.1-50.4 MHz which is incorrect.)

Page 3-2 – The Volunteer Monitor Program (VMP - [www.arrl.org/volunteer-monitor-program](http://www.arrl.org/volunteer-monitor-program)) is in full operation as of 1 Oct 2019. The Official Observer program was terminated on 30 Sep 2019.

Page 6-5 – Question G8A06 includes a comparison of bandwidth between the digital modes BPSK31 and QPSK31. The simplest and most common version of PSK31 that uses a single audio tone should be abbreviated as BPSK31 (binary PSK31).

**Page 11-37 – Question G4E07 is more easily understood as “Which of the following are common sources of received interference in a radio installed in a vehicle?”**

## ERRATA

### *General Class License Manual*

Page 1-9, 1-12, 1-13 – References to receiving a paper license are obsolete. The FCC no longer mails paper copies of license but you can download and print copies of your license from the FCC’s ULS website. The FCC website is available via the ARRL website at [www.arrl.org/fcc-license-info-and-forms](http://www.arrl.org/fcc-license-info-and-forms).

Page 2-9 – in the paragraph about CW, the second sentence should read, “It’s often forgotten that CW can be transmitted anywhere on the HF bands (including on the five 60 meter channels), including the portion allocated to phone operation!”

Page 3-2 – the reference to Part 97.305 (f) (11) should be to Part 97.307 (f) (11).

Page 3-7 – in the list of questions for section 3.3, question G1A04 should read “Which of the following amateur bands is restricted to communication only on specific channels, rather than frequency ranges?”

Page 3-8 – Under “Frequency Privileges” and referencing question G1A15, the allowed frequencies for repeater operation on the 10 meter band are 29.5 to 29.7 MHz.

Page 4-2 – In the example for G5B05, remember that 1.25 k $\Omega$  and 1250  $\Omega$  are equivalent.

Page 4-7 – The equation for PEP should be:

$$PEP = \frac{\left[ \frac{V_{P-P}}{2} \times 0.707 \right]^2}{R} = \frac{(PEV \times 0.707)^2}{R} = \frac{V_{RMS}^2}{R}$$

This equation should be used for the calculations supporting questions G5B06 and G5B14 lower on the page. The equations in the *General Q&A* are correct.

Page 4-11 – Example 18 should begin with the conversion from microhenries ( $\mu$ H) to nanohenries (nH) as follows: 6.8  $\mu$ H = 6.8  $\times$  1000 = 6800 nH. The conversion from  $\mu$ H to mH is correct.

Page 4-10, Example 16 – the first converted value should be 2,200,000  $\Omega$ .

Page 4-18, Example 20 – the equation should read:  
 $C_{EQU} = 5000 + 5000 + 750 = 10,750$  pF = 10.75 nF [G3C08]

Page 4-20, Example 26 – there is a typo in the equation which should show the inductor value of 10  $\mu$ H as ( $1 \times 10^{-5}$ ) not ( $1 \times 10^{-6}$ ) which would be 1  $\mu$ H. The reactance of 314  $\Omega$  is correct.

Page 4-35, Question G6A02 – change “ssbatteries” to “batteries”.

Page 5-15 – in the list of questions for section 5.4, question G4D04 should read “What does an S-meter measure?”

(eBook version only) Figure 5.17 is a duplicate of Figure 5.16. Here is the correct graphic:

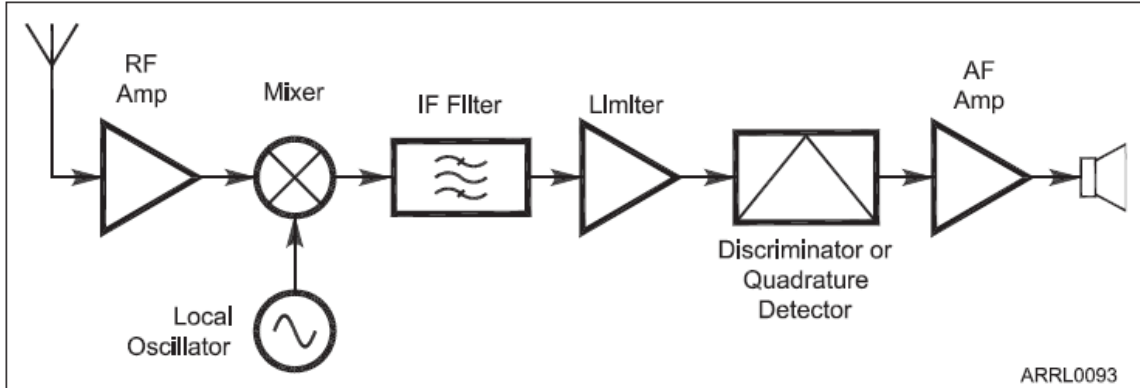

Page 6-9 – the first sentence of section 6.4 should read, “Most digital modes on HF are transmitted as USB signals except for RTTY which uses LSB.”

Page 6-10 – in the section “Staying in the Band” the calculation should be  $18103 - 2.295 = 18100.705$  kHz.

Page 6-13 – in Table 6.3 “Automatic Control Band Segments for RTTY and Data” the entry for 6 meters should be 50.1 – 54.0 MHz.

(eBook version only) Table 6.2 is shown as Figure 6.2. Here is the correct table:

**Table 6.2**  
**Bandwidth Comparison of Digital Modes**

<i>Mode</i>	<i>Bandwidth (Hz)</i>
PSK31	50
FT8	50
RTTY	200
MFSK16	300
JT65	350
DominoEX	524
Olivia	1000
WINMOR	1600
MT63	2000
FACTOR-III	2300
FACTOR-4	2300

Bandwidths are approximate for the highest commonly used symbol rate and are not specifications

Page 7-5 – In the second paragraph of the section Effects of Ground, both instances of “1/2 wavelength” should be “1/4 wavelength”.

Page 7-12 – In the second full paragraph, the beta or hairpin match figure reference should be to Figure 7.9C instead of 7.9B.

Page 7-21 – In Example 4, the equation should be:

$$SWR = \frac{200}{50} = 4 : 1$$

### *General Q&A*

Question G2C10 – the correct answer is D and is shown correctly in the main manual.

Question G5C07 – in the turns-ratio calculation, the correct value of 600 / 4 is 150, not 125.

Question G5C08 – in answer D, the value should be 10.750 not 10,750. 10.75 nF is equal to 10,7500 pF.

Question G7A03 – the correct answer is A and is shown correctly in the main manual.