

Study Guide for Exam Questions



Study Guide to Exam Questions

This version of the Question Pool has been rearranged to follow the topics as presented in the ARRL *General Class License Manual*, 8th edition. See the printed book for a version of the Question Pool arranged by Subelement, as released by the NCVEC Question Pool Committee. As you study, cover the answer key provided at the margin to test your knowledge. (Please note: Answer selections may be presented in a different order on the actual exam.)

Chapter 2 Section 2.1

G1B08

When choosing a transmitting frequency, what should you do to comply with good amateur practice?

- A. Insure that the frequency and mode selected are within your license class privileges
- B. Follow generally accepted band plans agreed to by the Amateur Radio community
- C. Monitor the frequency before transmitting
- D. All of these choices are correct

G2A01

Which sideband is most commonly used for voice communications on frequencies of 14 MHz or higher?

- A. Upper sideband
- B. Lower sideband
- C. Vestigial sideband
- D. Double sideband

G2A02

Which of the following modes is most commonly used for voice communications on the 160-meter, 75-meter, and 40-meter bands?

- A. Upper sideband
- B. Lower sideband
- C. Vestigial sideband
- D. Double sideband

G1B08
(D)
[97.101(a)]
Page 2-3

G2A01
(A)
Page 2-8

G2A02
(B)
Page 2-8

G2A03
(A)
Page 2-8

G2A03

Which of the following is most commonly used for SSB voice communications in the VHF and UHF bands?

- A. Upper sideband
- B. Lower sideband
- C. Vestigial sideband
- D. Double sideband

G2A04
(A)
Page 2-8

G2A04

Which mode is most commonly used for voice communications on the 17-meter and 12-meter bands?

- A. Upper sideband
- B. Lower sideband
- C. Vestigial sideband
- D. Double sideband

G2A05
(C)
Page 2-7

G2A05

Which mode of voice communication is most commonly used on the HF amateur bands?

- A. Frequency modulation
- B. Double sideband
- C. Single sideband
- D. Phase modulation

G2A06
(B)
Page 2-7

G2A06

Which of the following is an advantage when using single sideband as compared to other analog voice modes on the HF amateur bands?

- A. Very high fidelity voice modulation
- B. Less bandwidth used and greater power efficiency
- C. Ease of tuning on receive and immunity to impulse noise
- D. Less subject to interference from atmospheric static crashes

G2A07
(B)
Page 2-7

G2A07

Which of the following statements is true of the single sideband voice mode?

- A. Only one sideband and the carrier are transmitted; the other sideband is suppressed
- B. Only one sideband is transmitted; the other sideband and carrier are suppressed
- C. SSB is the only voice mode that is authorized on the 20-meter, 15-meter, and 10-meter amateur bands
- D. SSB is the only voice mode that is authorized on the 160-meter, 75-meter and 40-meter amateur bands

G2A08
(B)
Page 2-2

G2A08

Which of the following is a recommended way to break into a contact when using phone?

- A. Say "QRZ" several times followed by your call sign
- B. Say your call sign during a break between transmissions by the other stations
- C. Say "Break Break Break" and wait for a response
- D. Say "CQ" followed by the call sign of either station

G2A09

Why do most amateur stations use lower sideband on the 160-meter, 75-meter and 40-meter bands?

- A. Lower sideband is more efficient than upper sideband at these frequencies
- B. Lower sideband is the only sideband legal on these frequency bands
- C. Because it is fully compatible with an AM detector
- D. Current amateur practice is to use lower sideband on these frequency bands

G2A09

(D)

Page 2-8

G2A10

Which of the following statements is true of voice VOX operation versus PTT operation?

- A. The received signal is more natural sounding
- B. It allows “hands free” operation
- C. It occupies less bandwidth
- D. It provides more power output

G2A10

(B)

Page 2-10

G2A11

What does the expression “CQ DX” usually indicate?

- A. A general call for any station
- B. The caller is listening for a station in Germany
- C. The caller is looking for any station outside their own country
- D. A distress call

G2A11

(C)

Page 2-2

G2B01

Which of the following is true concerning access to frequencies in non-emergency situations?

- A. Nets always have priority
- B. QSOs in progress always have priority
- C. Except during FCC declared emergencies, no one has priority access to frequencies
- D. Contest operations must always yield to non-contest use of frequencies

G2B01

(C)

Page 2-3

G2B03

If propagation changes during your contact and you notice increasing interference from other activity on the same frequency, what should you do?

- A. Tell the interfering stations to change frequency
- B. Report the interference to your local Amateur Auxiliary Coordinator
- C. As a common courtesy, move your contact to another frequency
- D. Increase power to overcome interference

G2B03

(C)

Page 2-7

G2B04

When selecting a CW transmitting frequency, what minimum separation should be used to minimize interference to stations on adjacent frequencies?

- A. 5 to 50 Hz
- B. 150 to 500 Hz
- C. 1 to 3 kHz
- D. 3 to 6 kHz

G2B04

(B)

Page 2-3

G2B05
(B)
Page 2-3

G2B05
What is the customary minimum frequency separation between SSB signals under normal conditions?
A. Between 150 and 500 Hz
B. Approximately 3 kHz
C. Approximately 6 kHz
D. Approximately 10 kHz

G2B06
(A)
Page 2-3

G2B06
What is a practical way to avoid harmful interference on an apparently clear frequency before calling CQ on CW or phone?
A. Send "QRL?" on CW, followed by your call sign; or, if using phone, ask if the frequency is in use, followed by your call sign
B. Listen for 2 minutes before calling CQ
C. Send the letter "V" in Morse code several times and listen for a response or say "test" several times and listen for a response
D. Send "QSY" on CW or if using phone, announce "the frequency is in use", then give your call and listen for a response

G2B07
(C)
Page 2-2

G2B07
Which of the following complies with good amateur practice when choosing a frequency on which to initiate a call?
A. Check to see if the channel is assigned to another station
B. Identify your station by transmitting your call sign at least 3 times
C. Follow the voluntary band plan for the operating mode you intend to use
D. All of these choices are correct

G2B08
(A)
Page 2-4

G2B08
What is the "DX window" in a voluntary band plan?
A. A portion of the band that should not be used for contacts between stations within the 48 contiguous United States
B. An FCC rule that prohibits contacts between stations within the United States and possessions in that portion of the band
C. An FCC rule that allows only digital contacts in that portion of the band
D. A portion of the band that has been voluntarily set aside for digital contacts only

G2C01
(D)
Page 2-12

G2C01
Which of the following describes full break-in telegraphy (QSK)?
A. Breaking stations send the Morse code prosign BK
B. Automatic keyers are used to send Morse code instead of hand keys
C. An operator must activate a manual send/receive switch before and after every transmission
D. Transmitting stations can receive between code characters and elements

G2C02
(A)
Page 2-12

G2C02
What should you do if a CW station sends "QRS"?
A. Send slower
B. Change frequency
C. Increase your power
D. Repeat everything twice

G2C03

What does it mean when a CW operator sends “KN” at the end of a transmission?

- A. Listening for novice stations
- B. Operating full break-in
- C. Listening only for a specific station or stations
- D. Closing station now

G2C03

(C)

Page 2-12

G2C04

What does the Q signal “QRL?” mean?

- A. “Will you keep the frequency clear?”
- B. “Are you operating full break-in” or “Can you operate full break-in?”
- C. “Are you listening only for a specific station?”
- D. “Are you busy?”, or “Is this frequency in use?”

G2C04

(D)

Page 2-3

G2C05

What is the best speed to use when answering a CQ in Morse code?

- A. The fastest speed at which you are comfortable copying
- B. The speed at which the CQ was sent
- C. A slow speed until contact is established
- D. At the standard calling speed of 5 wpm

G2C05

(B)

Page 2-12

G2C06

What does the term “zero beat” mean in CW operation?

- A. Matching the speed of the transmitting station
- B. Operating split to avoid interference on frequency
- C. Sending without error
- D. Matching your transmit frequency to the frequency of a received signal

G2C06

(D)

Page 2-12

G2C07

When sending CW, what does a “C” mean when added to the RST report?

- A. Chirpy or unstable signal
- B. Report was read from an S meter rather than estimated
- C. 100 percent copy
- D. Key clicks

G2C07

(A)

Page 2-11

G2C08

What prosign is sent to indicate the end of a formal message when using CW?

- A. SK
- B. BK
- C. AR
- D. KN

G2C08

(C)

Page 2-12

G2C09

What does the Q signal “QSL” mean?

- A. Send slower
- B. We have already confirmed by card
- C. I acknowledge receipt
- D. We have worked before

G2C09

(C)

Page 2-12

G2C10
(B)
Page 2-9

G2C10
What does the Q signal “QRN” mean?
A. Send more slowly
B. I am troubled by static
C. Zero beat my signal
D. Stop sending

G2C11
(D)
Page 2-12

G2C11
What does the Q signal “QRV” mean?
A. You are sending too fast
B. There is interference on the frequency
C. I am quitting for the day
D. I am ready to receive messages

G2D08
(D)
Page 2-5

G2D08
What is a reason why many amateurs keep a station log?
A. The ITU requires a log of all international contacts
B. The ITU requires a log of all international third party traffic
C. The log provides evidence of operation needed to renew a license without retest
D. To help with a reply if the FCC requests information

G2D09
(D)
Page 2-5

G2D09
What information is traditionally contained in a station log?
A. Date and time of contact
B. Band and/or frequency of the contact
C. Call sign of station contacted and the signal report given
D. All of these choices are correct

G4A10
(B)
Page 2-11

G4A10
What is the purpose of an electronic keyer?
A. Automatic transmit/receive switching
B. Automatic generation of strings of dots and dashes for CW operation
C. VOX operation
D. Computer interface for PSK and RTTY operation

Section 2.2

G1B04
(A)
[97.113(b)]
Page 2-13

G1B04
Which of the following must be true before amateur stations may provide communications to broadcasters for dissemination to the public?
A. The communications must directly relate to the immediate safety of human life or protection of property and there must be no other means of communication reasonably available before or at the time of the event
B. The communications must be approved by a local emergency preparedness official and conducted on officially designated frequencies
C. The FCC must have declared a state of emergency
D. All of these choices are correct

G2B02

What is the first thing you should do if you are communicating with another amateur station and hear a station in distress break in?

- A. Continue your communication because you were on the frequency first
- B. Acknowledge the station in distress and determine what assistance may be needed
- C. Change to a different frequency
- D. Immediately cease all transmissions

G2B02

(B)

Page 2-15

G2B09

Who may be the control operator of an amateur station transmitting in RACES to assist relief operations during a disaster?

- A. Only a person holding an FCC issued amateur operator license
- B. Only a RACES net control operator
- C. A person holding an FCC issued amateur operator license or an appropriate government official
- D. Any control operator when normal communication systems are operational

G2B09

(A)

[97.407(a)]

Page 2-13

G2B10

When may the FCC restrict normal frequency operations of amateur stations participating in RACES?

- A. When they declare a temporary state of communication emergency
- B. When they seize your equipment for use in disaster communications
- C. Only when all amateur stations are instructed to stop transmitting
- D. When the President's War Emergency Powers have been invoked

G2B10

(D)

[97.407(b)]

Page 2-14

G2B11

What frequency should be used to send a distress call?

- A. Whichever frequency has the best chance of communicating the distress message
- B. Only frequencies authorized for RACES or ARES stations
- C. Only frequencies that are within your operating privileges
- D. Only frequencies used by police, fire or emergency medical services

G2B11

(A)

[97.405]

Page 2-16

G2B12

When is an amateur station allowed to use any means at its disposal to assist another station in distress?

- A. Only when transmitting in RACES
- B. At any time when transmitting in an organized net
- C. At any time during an actual emergency
- D. Only on authorized HF frequencies

G2B12

(C)

[97.405(b)]

Page 2-16

Chapter 3

Section 3.1

G1A14
(B)
[97.301(d)]
Page 3-2

G1A14

In what ITU region is operation in the 7.175 to 7.300 MHz band permitted for a control operator holding an FCC issued General Class license?

- A. Region 1
- B. Region 2
- C. Region 3
- D. All three regions

G1B01
(C)
[97.15(a)]
Page 3-2

G1B01

What is the maximum height above ground to which an antenna structure may be erected without requiring notification to the FAA and registration with the FCC, provided it is not at or near a public use airport?

- A. 50 feet
- B. 100 feet
- C. 200 feet
- D. 300 feet

G2D01
(A)
Page 3-2

G2D01

What is the Amateur Auxiliary to the FCC?

- A. Amateur volunteers who are formally enlisted to monitor the airwaves for rules violations
- B. Amateur volunteers who conduct amateur licensing examinations
- C. Amateur volunteers who conduct frequency coordination for amateur VHF repeaters
- D. Amateur volunteers who use their station equipment to help civil defense organizations in times of emergency

G2D02
(B)
Page 3-2

G2D02

Which of the following are objectives of the Amateur Auxiliary?

- A. To conduct efficient and orderly amateur licensing examinations
- B. To encourage self-regulation and compliance with the rules by radio amateur operators
- C. To coordinate repeaters for efficient and orderly spectrum usage
- D. To provide emergency and public safety communications

G2D03
(B)
Page 3-2

G2D03

What skills learned during hidden transmitter hunts are of help to the Amateur Auxiliary?

- A. Identification of out of band operation
- B. Direction finding used to locate stations violating FCC Rules
- C. Identification of different call signs
- D. Hunters have an opportunity to transmit on non-amateur frequencies

Section 3.2

G1D01

Who may receive credit for the elements represented by an expired amateur radio license?

- A. Any person who can demonstrate that they once held an FCC issued General, Advanced, or Amateur Extra class license that was not revoked by the FCC
- B. Anyone who held an FCC issued amateur radio license that has been expired for not less than 5 years and not more than 15 years
- C. Any person who previously held an amateur license issued by another country, but only if that country has a current reciprocal licensing agreement with the FCC
- D. Only persons who once held an FCC issued Novice, Technician, or Technician Plus license

G1D01

(A)

[97.501, 97.505(a)]

Page 3-3

G1D02

What license examinations may you administer when you are an accredited VE holding a General Class operator license?

- A. General and Technician
- B. General only
- C. Technician only
- D. Extra, General and Technician

G1D02

(C)

[97.509(b)(3)(i)]

Page 3-4

G1D03

On which of the following band segments may you operate if you are a Technician Class operator and have a CSCE for General Class privileges?

- A. Only the Technician band segments until your upgrade is posted in the FCC database
- B. Only on the Technician band segments until your license arrives in the mail
- C. On any General or Technician Class band segment
- D. On any General or Technician Class band segment except 30-meters and 60-meters

G1D03

(C)

[97.9(b)]

Page 3-6

G1D04

Which of the following is a requirement for administering a Technician Class license examination?

- A. At least three General Class or higher VEs must observe the examination
- B. At least two General Class or higher VEs must be present
- C. At least two General Class or higher VEs must be present, but only one need be Extra Class
- D. At least three VEs of Technician Class or higher must observe the examination

G1D04

(A)

[97.509(a),(b)]

Page 3-4

G1D05

Which of the following must a person have before they can be an administering VE for a Technician Class license examination?

- A. Notification to the FCC that you want to give an examination
- B. Receipt of a CSCE for General Class
- C. Possession of a properly obtained telegraphy license
- D. An FCC General Class or higher license and VEC accreditation

G1D05

(D)

[97.509(b)(3)(i)]

Page 3-3

G1D06
(A)
[97.119(f)(2)]
Page 3-6

G1D06

When must you add the special identifier “AG” after your call sign if you are a Technician Class licensee and have a CSCE for General Class operator privileges, but the FCC has not yet posted your upgrade on its website?

- A. Whenever you operate using General Class frequency privileges
- B. Whenever you operate on any amateur frequency
- C. Whenever you operate using Technician frequency privileges
- D. A special identifier is not required as long as your General Class license application has been filed with the FCC

G1D07
(C)
[97.509(b)(1)]
Page 3-3

G1D07

Volunteer Examiners are accredited by what organization?

- A. The Federal Communications Commission
- B. The Universal Licensing System
- C. A Volunteer Examiner Coordinator
- D. The Wireless Telecommunications Bureau

G1D08
(B)
[97.509(b)(3)]
Page 3-3

G1D08

Which of the following criteria must be met for a non-U.S. citizen to be an accredited Volunteer Examiner?

- A. The person must be a resident of the U.S. for a minimum of 5 years
- B. The person must hold an FCC granted Amateur Radio license of General Class or above
- C. The person’s home citizenship must be in ITU region 2
- D. None of these choices is correct; a non-U.S. citizen cannot be a Volunteer Examiner

G1D09
(C)
[97.9(b)]
Page 3-4

G1D09

How long is a Certificate of Successful Completion of Examination (CSCE) valid for exam element credit?

- A. 30 days
- B. 180 days
- C. 365 days
- D. For as long as your current license is valid

G1D10
(B)
[97.509(b)(2)]
Page 3-3

G1D10

What is the minimum age that one must be to qualify as an accredited Volunteer Examiner?

- A. 12 years
- B. 18 years
- C. 21 years
- D. There is no age limit

G1D11
(D)
Page 3-3

G1D11

If a person has an expired FCC issued amateur radio license of General Class or higher, what is required before they can receive a new license?

- A. They must have a letter from the FCC showing they once held an amateur or commercial license
- B. There are no requirements other than being able to show a copy of the expired license
- C. The applicant must be able to produce a copy of a page from a call book published in the USA showing his or her name and address
- D. The applicant must pass the current element 2 exam

G1E09

What language must be used when identifying your station if you are using a language other than English in making a contact using phone emission?

- A. The language being used for the contact
- B. Any language recognized by the United Nations
- C. English only
- D. English, Spanish, French, or German

G1E09

(C)
[97.119(b)(2)]
Page 3-6

Section 3.3

G1A01

On which of the following bands is a General Class license holder granted all amateur frequency privileges?

- A. 60, 20, 17, and 12 meters
- B. 160, 80, 40, and 10 meters
- C. 160, 60, 30, 17, 12, and 10 meters
- D. 160, 30, 17, 15, 12, and 10 meters

G1A01

(C)
[97.301(d)]
Page 3-8

G1A02

On which of the following bands is phone operation prohibited?

- A. 160 meters
- B. 30 meters
- C. 17 meters
- D. 12 meters

G1A02

(B)
[97.305]
Page 3-8

G1A03

On which of the following bands is image transmission prohibited?

- A. 160 meters
- B. 30 meters
- C. 20 meters
- D. 12 meters

G1A03

(B)
[97.305]
Page 3-8

G1A04

Which of the following amateur bands is restricted to communication on only specific channels, rather than frequency ranges?

- A. 11 meters
- B. 12 meters
- C. 30 meters
- D. 60 meters

G1A04

(D)
[97.303 (h)]
Page 3-8

G1A05

Which of the following frequencies is in the General Class portion of the 40-meter band?

- A. 7.250 MHz
- B. 7.500 MHz
- C. 40.200 MHz
- D. 40.500 MHz

G1A05

(A)
[97.301(d)]
Page 3-7

G1A06
(C)
[97.301(d)]
Page 3-8

G1A06
Which of the following frequencies is within the General Class portion of the 75-meter phone band?
A. 1875 kHz
B. 3750 kHz
C. 3900 kHz
D. 4005 kHz

G1A07
(C)
[97.301(d)]
Page 3-7

G1A07
Which of the following frequencies is within the General Class portion of the 20-meter phone band?
A. 14005 kHz
B. 14105 kHz
C. 14305 kHz
D. 14405 kHz

G1A08
(C)
[97.301(d)]
Page 3-7

G1A08
Which of the following frequencies is within the General Class portion of the 80-meter band?
A. 1855 kHz
B. 2560 kHz
C. 3560 kHz
D. 3650 kHz

G1A09
(C)
[97.301(d)]
Page 3-7

G1A09
Which of the following frequencies is within the General Class portion of the 15-meter band?
A. 14250 kHz
B. 18155 kHz
C. 21300 kHz
D. 24900 kHz

G1A10
(D)
[97.301(d)]
Page 3-7

G1A10
Which of the following frequencies is available to a control operator holding a General Class license?
A. 28.020 MHz
B. 28.350 MHz
C. 28.550 MHz
D. All of these choices are correct

G1A11
(B)
[97.301]
Page 3-8

G1A11
When General Class licensees are not permitted to use the entire voice portion of a particular band, which portion of the voice segment is generally available to them?
A. The lower frequency end
B. The upper frequency end
C. The lower frequency end on frequencies below 7.3 MHz and the upper end on frequencies above 14.150 MHz
D. The upper frequency end on frequencies below 7.3 MHz and the lower end on frequencies above 14.150 MHz

G1A12

Which of the following applies when the FCC rules designate the Amateur Service as a secondary user on a band?

- A. Amateur stations must record the call sign of the primary service station before operating on a frequency assigned to that station
- B. Amateur stations are allowed to use the band only during emergencies
- C. Amateur stations are allowed to use the band only if they do not cause harmful interference to primary users
- D. Amateur stations may only operate during specific hours of the day, while primary users are permitted 24 hour use of the band

G1A12
(C)
[97.303]
Page 3-8

G1A13

What is the appropriate action if, when operating on either the 30-meter or 60-meter bands, a station in the primary service interferes with your contact?

- A. Notify the FCC's regional Engineer in Charge of the interference
- B. Increase your transmitter's power to overcome the interference
- C. Attempt to contact the station and request that it stop the interference
- D. Move to a clear frequency or stop transmitting

G1A13
(D)
[97.303(h)(2)(j)]
Page 3-8

G1B02

With which of the following conditions must beacon stations comply?

- A. A beacon station may not use automatic control
- B. The frequency must be coordinated with the National Beacon Organization
- C. The frequency must be posted on the Internet or published in a national periodical
- D. There must be no more than one beacon signal transmitting in the same band from the same station location

G1B02
(D)
[97.203(b)]
Page 3-9

G1B03

Which of the following is a purpose of a beacon station as identified in the FCC rules?

- A. Observation of propagation and reception
- B. Automatic identification of repeaters
- C. Transmission of bulletins of general interest to Amateur Radio licensees
- D. Identifying net frequencies

G1B03
(A)
[97.3(a)(9)]
Page 3-8

G1B05

When may music be transmitted by an amateur station?

- A. At any time, as long as it produces no spurious emissions
- B. When it is unintentionally transmitted from the background at the transmitter
- C. When it is transmitted on frequencies above 1215 MHz
- D. When it is an incidental part of a manned space craft retransmission

G1B05
(D)
[97.113(c)]
Page 3-10

G1B06

When is an amateur station permitted to transmit secret codes?

- A. During a declared communications emergency
- B. To control a space station
- C. Only when the information is of a routine, personal nature
- D. Only with Special Temporary Authorization from the FCC

G1B06
(B)
[97.113(a)(4)
and 97.207(f)]
Page 3-11

<p>G1B07 (B) [97.113(a)(4)] Page 3-11</p>	<p>G1B07 What are the restrictions on the use of abbreviations or procedural signals in the Amateur Service? A. Only “Q” signals are permitted B. They may be used if they do not obscure the meaning of a message C. They are not permitted D. Only “10 codes” are permitted</p>
<p>G1B09 (A) [97.113(a)(3)] Page 3-12</p>	<p>G1B09 When may an amateur station transmit communications in which the licensee or control operator has a pecuniary (monetary) interest? A. When other amateurs are being notified of the sale of apparatus normally used in an amateur station and such activity is not done on a regular basis B. Only when there is no other means of communications readily available C. When other amateurs are being notified of the sale of any item with a monetary value less than \$200 and such activity is not done on a regular basis D. Never</p>
<p>G1B10 (C) [97.203(c)] Page 3-9</p>	<p>G1B10 What is the power limit for beacon stations? A. 10 watts PEP output B. 20 watts PEP output C. 100 watts PEP output D. 200 watts PEP output</p>
<p>G1E01 (A) [97.115(b)(2)] Page 3-10</p>	<p>G1E01 Which of the following would disqualify a third party from participating in stating a message over an amateur station? A. The third party’s amateur license has been revoked and not reinstated B. The third party is not a U.S. citizen C. The third party is a licensed amateur D. The third party is speaking in a language other than English</p>
<p>G1E02 (D) [97.205(a)] Page 3-12</p>	<p>G1E02 When may a 10-meter repeater retransmit the 2-meter signal from a station having a Technician Class control operator? A. Under no circumstances B. Only if the station on 10-meters is operating under a Special Temporary Authorization allowing such retransmission C. Only during an FCC declared general state of communications emergency D. Only if the 10-meter repeater control operator holds at least a General Class license</p>
<p>G1E04 (D) [97.13(b), 97.303, 97.311(b)] Page 3-9</p>	<p>G1E04 Which of the following conditions require a licensed Amateur Radio operator to take specific steps to avoid harmful interference to other users or facilities? A. When operating within one mile of an FCC Monitoring Station B. When using a band where the Amateur Service is secondary C. When a station is transmitting spread spectrum emissions D. All of these choices are correct</p>

G1E05

What types of messages for a third party in another country may be transmitted by an amateur station?

- A. Any message, as long as the amateur operator is not paid
- B. Only messages for other licensed amateurs
- C. Only messages relating to Amateur Radio or remarks of a personal character, or messages relating to emergencies or disaster relief
- D. Any messages, as long as the text of the message is recorded in the station log

G1E05

(C)
[97.115(a)(2),97.117]
Page 3-9

G1E06

Which of the following applies in the event of interference between a coordinated repeater and an uncoordinated repeater?

- A. The licensee of the uncoordinated repeater has primary responsibility to resolve the interference
- B. The licensee of the coordinated repeater has primary responsibility to resolve the interference
- C. Both repeater licensees share equal responsibility to resolve the interference
- D. The frequency coordinator bears primary responsibility to resolve the interference

G1E06

(A)
[97.205(c)]
Page 3-9

G1E07

With which foreign countries is third party traffic prohibited, except for messages directly involving emergencies or disaster relief communications?

- A. Countries in ITU Region 2
- B. Countries in ITU Region 1
- C. Every foreign country, unless there is a third party agreement in effect with that country
- D. Any country which is not a member of the International Amateur Radio Union (IARU)

G1E07

(C)
[97.115(a)(2)]
Page 3-10

G1E08

Which of the following is a requirement for a non-licensed person to communicate with a foreign Amateur Radio station from a station with an FCC-granted license at which an FCC licensed control operator is present?

- A. Information must be exchanged in English
- B. The foreign amateur station must be in a country with which the United States has a third party agreement
- C. The control operator must have at least a General Class license
- D. All of these choices are correct

G1E08

(B)
[97.115(a)(b)]
Page 3-10

G2D05

When is it permissible to communicate with amateur stations in countries outside the areas administered by the Federal Communications Commission?

- A. Only when the foreign country has a formal third party agreement filed with the FCC
- B. When the contact is with amateurs in any country except those whose administrations have notified the ITU that they object to such communications
- C. When the contact is with amateurs in any country as long as the communication is conducted in English
- D. Only when the foreign country is a member of the International Amateur Radio Union

G2D05

(B)
[97.111(a)(1)]
Page 3-9

G2D07

Which of the following is required by the FCC rules when operating in the 60-meter band?

- A. If you are using other than a dipole antenna, you must keep a record of the gain of your antenna
- B. You must keep a record of the date, time, frequency, power level and stations worked
- C. You must keep a record of all third party traffic
- D. You must keep a record of the manufacturer of your equipment and the antenna used

G2D07

(A)
[97.303(i)]
Page 3-12

Section 3.4

G1B11 (C) [97.101(a)] Page 3-13	G1B11 How does the FCC require an amateur station to be operated in all respects not specifically covered by the Part 97 rules? A. In conformance with the rules of the IARU B. In conformance with Amateur Radio custom C. In conformance with good engineering and good amateur practice D. All of these choices are correct
G1B12 (A) [97.101(a)] Page 3-13	G1B12 Who or what determines “good engineering and good amateur practice” as applied to the operation of an amateur station in all respects not covered by the Part 97 rules? A. The FCC B. The Control Operator C. The IEEE D. The ITU
G1C01 (A) [97.313(c)(1)] Page 3-13	G1C01 What is the maximum transmitting power an amateur station may use on 10.140 MHz? A. 200 watts PEP output B. 1000 watts PEP output C. 1500 watts PEP output D. 2000 watts PEP output
G1C02 (C) [97.313(a),(b)] Page 3-13	G1C02 What is the maximum transmitting power an amateur station may use on the 12-meter band? A. 50 watts PEP output B. 200 watts PEP output C. 1500 watts PEP output D. An effective radiated power equivalent to 100 watts from a half-wave dipole
G1C03 (A) [97.303(h)(1)] Page 3-14	G1C03 What is the maximum bandwidth permitted by FCC rules for Amateur Radio stations transmitting on USB frequencies in the 60-meter band? A. 2.8 kHz B. 5.6 kHz C. 1.8 kHz D. 3 kHz
G1C04 (A) [97.313(a)] Page 3-14	G1C04 Which of the following limitations apply to transmitter power on every amateur band? A. Only the minimum power necessary to carry out the desired communications should be used B. Power must be limited to 200 watts when transmitting between 14.100 MHz and 14.150 MHz C. Power should be limited as necessary to avoid interference to another radio service on the frequency D. Effective radiated power cannot exceed 1500 watts

G1C05

Which of the following is a limitation on transmitter power on the 28 MHz band for a General Class control operator?

- A. 100 watts PEP output
- B. 1000 watts PEP output
- C. 1500 watts PEP output
- D. 2000 watts PEP output

G1C05

(C)

[97.313(c)(2)]

Page 3-13

G1C06

Which of the following is a limitation on transmitter power on the 1.8 MHz band?

- A. 200 watts PEP output
- B. 1000 watts PEP output
- C. 1200 watts PEP output
- D. 1500 watts PEP output

G1C06

(D)

[97.313]

Page 3-13

G1C07

What is the maximum symbol rate permitted for RTTY or data emission transmission on the 20-meter band?

- A. 56 kilobaud
- B. 19.6 kilobaud
- C. 1200 baud
- D. 300 baud

G1C07

(D)

[97.305(c), 97.307(f)

(3)]

Page 3-14

G1C08

What is the maximum symbol rate permitted for RTTY or data emission transmitted at frequencies below 28 MHz?

- A. 56 kilobaud
- B. 19.6 kilobaud
- C. 1200 baud
- D. 300 baud

G1C08

(D)

[97.307(f)(3)]

Page 3-14

G1C09

What is the maximum symbol rate permitted for RTTY or data emission transmitted on the 1.25-meter and 70-centimeter bands?

- A. 56 kilobaud
- B. 19.6 kilobaud
- C. 1200 baud
- D. 300 baud

G1C09

(A)

[97.305(c) and

97.307(f)(5)]

Page 3-14

G1C10

What is the maximum symbol rate permitted for RTTY or data emission transmissions on the 10-meter band?

- A. 56 kilobaud
- B. 19.6 kilobaud
- C. 1200 baud
- D. 300 baud

G1C10

(C)

[97.305(c) and

97.307(f)(4)]

Page 3-14

G1C11
(B)
[97.305(c) and
97.307(f)(5)]
Page 3-14

G1C11
What is the maximum symbol rate permitted for RTTY or data emission transmissions on the 2-meter band?
A. 56 kilobaud
B. 19.6 kilobaud
C. 1200 baud
D. 300 baud

G2D10
(B)
Page 3-13

G2D10
What is QRP operation?
A. Remote piloted model control
B. Low power transmit operation
C. Transmission using Quick Response Protocol
D. Traffic relay procedure net operation

Chapter 4

Section 4.1

G5B01
(B)
Page 4-3

G5B01
What dB change represents a two-times increase or decrease in power?
A. Approximately 2 dB
B. Approximately 3 dB
C. Approximately 6 dB
D. Approximately 12 dB

G5B03
(B)
Page 4-2

G5B03
How many watts of electrical power are used if 400 VDC is supplied to an 800 ohm load?
A. 0.5 watts
B. 200 watts
C. 400 watts
D. 3200 watts

G5B04
(A)
Page 4-2

G5B04
How many watts of electrical power are used by a 12 VDC light bulb that draws 0.2 amperes?
A. 2.4 watts
B. 24 watts
C. 6 watts
D. 60 watts

G5B05
(A)
Page 4-2

G5B05
How many watts are dissipated when a current of 7.0 milliamperes flows through 1.25 kilohms resistance?
A. Approximately 61 milliwatts
B. Approximately 61 watts
C. Approximately 11 milliwatts
D. Approximately 11 watts

G5B10

What percentage of power loss would result from a transmission line loss of 1 dB?

- A. 10.9 percent
- B. 12.2 percent
- C. 20.5 percent
- D. 25.9 percent

G5B10

(C)

Page 4-4

Section 4.2

G5B06

What is the output PEP from a transmitter if an oscilloscope measures 200 volts peak-to-peak across a 50 ohm dummy load connected to the transmitter output?

- A. 1.4 watts
- B. 100 watts
- C. 353.5 watts
- D. 400 watts

G5B06

(B)

Page 4-6

G5B07

What value of an AC signal produces the same power dissipation in a resistor as a DC voltage of the same value?

- A. The peak-to-peak value
- B. The peak value
- C. The RMS value
- D. The reciprocal of the RMS value

G5B07

(C)

Page 4-5

G5B09

What is the RMS voltage of a sine wave with a value of 17 volts peak?

- A. 8.5 volts
- B. 12 volts
- C. 24 volts
- D. 34 volts

G5B09

(B)

Page 4-6

G5B11

What is the ratio of peak envelope power to average power for an unmodulated carrier?

- A. 0.707
- B. 1.00
- C. 1.414
- D. 2.00

G5B11

(B)

Page 4-7

G5B12

What would be the RMS voltage across a 50 ohm dummy load dissipating 1200 watts?

- A. 173 volts
- B. 245 volts
- C. 346 volts
- D. 692 volts

G5B12

(B)

Page 4-6

G5B13
(B)
Page 4-7

G5B13

What is the output PEP of an unmodulated carrier if an average reading wattmeter connected to the transmitter output indicates 1060 watts?

- A. 530 watts
- B. 1060 watts
- C. 1500 watts
- D. 2120 watts

G5B14
(B)
Page 4-6

G5B14

What is the output PEP from a transmitter if an oscilloscope measures 500 volts peak-to-peak across a 50 ohm resistive load connected to the transmitter output?

- A. 8.75 watts
- B. 625 watts
- C. 2500 watts
- D. 5000 watts

Section 4.3

G5B02
(C)
Page 4-12

G5B02

How does the total current relate to the individual currents in each branch of a purely resistive parallel circuit?

- A. It equals the average of each branch current
- B. It decreases as more parallel branches are added to the circuit
- C. It equals the sum of the currents through each branch
- D. It is the sum of the reciprocal of each individual voltage drop

G5C01
(C)
Page 4-15

G5C01

What causes a voltage to appear across the secondary winding of a transformer when an AC voltage source is connected across its primary winding?

- A. Capacitive coupling
- B. Displacement current coupling
- C. Mutual inductance
- D. Mutual capacitance

G5C02
(A)
Page 4-16

G5C02

What happens if you reverse the primary and secondary windings of a 4:1 voltage step down transformer?

- A. The secondary voltage becomes 4 times the primary voltage
- B. The transformer no longer functions as it is a unidirectional device
- C. Additional resistance must be added in series with the primary to prevent overload
- D. Additional resistance must be added in parallel with the secondary to prevent overload

G5C03

Which of the following components should be added to an existing resistor to increase the resistance?

- A. A resistor in parallel
- B. A resistor in series
- C. A capacitor in series
- D. A capacitor in parallel

G5C03

(B)

Page 4-13

G5C04

What is the total resistance of three 100 ohm resistors in parallel?

- A. 0.30 ohms
- B. 0.33 ohms
- C. 33.3 ohms
- D. 300 ohms

G5C04

(C)

Page 4-14

G5C05

If three equal value resistors in series produce 450 ohms, what is the value of each resistor?

- A. 1500 ohms
- B. 90 ohms
- C. 150 ohms
- D. 175 ohms

G5C05

(C)

Page 4-15

G5C06

What is the RMS voltage across a 500-turn secondary winding in a transformer if the 2250-turn primary is connected to 120 VAC?

- A. 2370 volts
- B. 540 volts
- C. 26.7 volts
- D. 5.9 volts

G5C06

(C)

Page 4-16

G5C08

What is the equivalent capacitance of two 5.0 nanofarad capacitors and one 750 picofarad capacitor connected in parallel?

- A. 576.9 nanofarads
- B. 1733 picofarads
- C. 3583 picofarads
- D. 10.750 nanofarads

G5C08

(D)

Page 4-15

G5C09

What is the capacitance of three 100 microfarad capacitors connected in series?

- A. 0.30 microfarads
- B. 0.33 microfarads
- C. 33.3 microfarads
- D. 300 microfarads

G5C09

(C)

Page 4-14

G5C10
(C)
Page 4-14

G5C10
What is the inductance of three 10 millihenry inductors connected in parallel?
A. 0.30 henrys
B. 3.3 henrys
C. 3.3 millihenrys
D. 30 millihenrys

G5C11
(C)
Page 4-14

G5C11
What is the inductance of a 20 millihenry inductor connected in series with a 50 millihenry inductor?
A. 0.07 millihenrys
B. 14.3 millihenrys
C. 70 millihenrys
D. 1000 millihenrys

G5C12
(B)
Page 4-14

G5C12
What is the capacitance of a 20 microfarad capacitor connected in series with a 50 microfarad capacitor?
A. 0.07 microfarads
B. 14.3 microfarads
C. 70 microfarads
D. 1000 microfarads

G5C13
(C)
Page 4-13

G5C13
Which of the following components should be added to a capacitor to increase the capacitance?
A. An inductor in series
B. A resistor in series
C. A capacitor in parallel
D. A capacitor in series

G5C14
(D)
Page 4-13

G5C14
Which of the following components should be added to an inductor to increase the inductance?
A. A capacitor in series
B. A resistor in parallel
C. An inductor in parallel
D. An inductor in series

G5C15
(A)
Page 4-14

G5C15
What is the total resistance of a 10 ohm, a 20 ohm, and a 50 ohm resistor connected in parallel?
A. 5.9 ohms
B. 0.17 ohms
C. 10000 ohms
D. 80 ohms

G5C16

Why is the conductor of the primary winding of many voltage step up transformers larger in diameter than the conductor of the secondary winding?

- A. To improve the coupling between the primary and secondary
- B. To accommodate the higher current of the primary
- C. To prevent parasitic oscillations due to resistive losses in the primary
- D. To insure that the volume of the primary winding is equal to the volume of the secondary winding

G5C16
(B)
Page 4-15

G5C17

What is the value in nanofarads (nF) of a 22,000 pF capacitor?

- A. 0.22 nF
- B. 2.2 nF
- C. 22 nF
- D. 220 nF

G5C17
(C)
Page 4-7

G5C18

What is the value in microfarads of a 4700 nanofarad (nF) capacitor?

- A. 47 μ F
- B. 0.47 μ F
- C. 47,000 μ F
- D. 4.7 μ F

G5C18
(D)
Page 4-7

G6A13

Why is the polarity of applied voltages important for polarized capacitors?

- A. Incorrect polarity can cause the capacitor to short-circuit
- B. Reverse voltages can destroy the dielectric layer of an electrolytic capacitor
- C. The capacitor could overheat and explode
- D. All of these choices are correct

G6A13
(D)
Page 4-12

G6A14

Which of the following is an advantage of ceramic capacitors as compared to other types of capacitors?

- A. Tight tolerance
- B. High stability
- C. High capacitance for given volume
- D. Comparatively low cost

G6A14
(D)
Page 4-11

G6A15

Which of the following is an advantage of an electrolytic capacitor?

- A. Tight tolerance
- B. Much less leakage than any other type
- C. High capacitance for a given volume
- D. Inexpensive RF capacitor

G6A15
(C)
Page 4-11

G6A16
(C)
Page 4-9

G6A16

What will happen to the resistance if the temperature of a resistor is increased?

- A. It will change depending on the resistor's reactance coefficient
- B. It will stay the same
- C. It will change depending on the resistor's temperature coefficient
- D. It will become time dependent

G6A17
(B)
Page 4-9

G6A17

Which of the following is a reason not to use wire-wound resistors in an RF circuit?

- A. The resistor's tolerance value would not be adequate for such a circuit
- B. The resistor's inductance could make circuit performance unpredictable
- C. The resistor could overheat
- D. The resistor's internal capacitance would detune the circuit

G6A18
(D)
Page 4-11

G6A18

What is an advantage of using a ferrite core toroidal inductor?

- A. Large values of inductance may be obtained
- B. The magnetic properties of the core may be optimized for a specific range of frequencies
- C. Most of the magnetic field is contained in the core
- D. All of these choices are correct

G6A19
(C)
Page 4-10

G6A19

How should the winding axes of two solenoid inductors be oriented to minimize their mutual inductance?

- A. In line
- B. Parallel to each other
- C. At right angles to each other
- D. Interleaved

Figure G7-1
 — This figure
 is used for
 questions G7A09
 through G7A13.

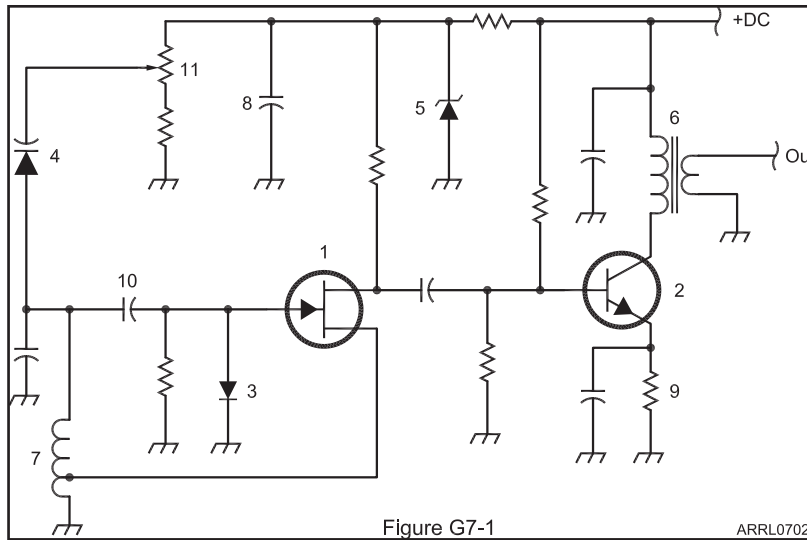

G7A09

Which symbol in figure G7-1 represents a field effect transistor?

- A. Symbol 2
- B. Symbol 5
- C. Symbol 1
- D. Symbol 4

G7A09

(C)

Page 4-7

G7A10

Which symbol in figure G7-1 represents a Zener diode?

- A. Symbol 4
- B. Symbol 1
- C. Symbol 11
- D. Symbol 5

G7A10

(D)

Page 4-7

G7A11

Which symbol in figure G7-1 represents an NPN junction transistor?

- A. Symbol 1
- B. Symbol 2
- C. Symbol 7
- D. Symbol 11

G7A11

(B)

Page 4-7

G7A12

Which symbol in Figure G7-1 represents a multiple-winding transformer?

- A. Symbol 4
- B. Symbol 7
- C. Symbol 6
- D. Symbol 1

G7A12

(C)

Page 4-7

G7A13

Which symbol in Figure G7-1 represents a tapped inductor?

- A. Symbol 7
- B. Symbol 11
- C. Symbol 6
- D. Symbol 1

G7A13

(A)

Page 4-7

Section 4.4

G5A01
(C)
Page 4-18

G5A01
What is impedance?
A. The electric charge stored by a capacitor
B. The inverse of resistance
C. The opposition to the flow of current in an AC circuit
D. The force of repulsion between two similar electric fields

G5A02
(B)
Page 4-16

G5A02
What is reactance?
A. Opposition to the flow of direct current caused by resistance
B. Opposition to the flow of alternating current caused by capacitance or inductance
C. A property of ideal resistors in AC circuits
D. A large spark produced at switch contacts when an inductor is de-energized

G5A03
(D)
Page 4-16

G5A03
Which of the following causes opposition to the flow of alternating current in an inductor?
A. Conductance
B. Reluctance
C. Admittance
D. Reactance

G5A04
(C)
Page 4-16

G5A04
Which of the following causes opposition to the flow of alternating current in a capacitor?
A. Conductance
B. Reluctance
C. Reactance
D. Admittance

G5A05
(D)
Page 4-18

G5A05
How does an inductor react to AC?
A. As the frequency of the applied AC increases, the reactance decreases
B. As the amplitude of the applied AC increases, the reactance increases
C. As the amplitude of the applied AC increases, the reactance decreases
D. As the frequency of the applied AC increases, the reactance increases

G5A06
(A)
Page 4-17

G5A06
How does a capacitor react to AC?
A. As the frequency of the applied AC increases, the reactance decreases
B. As the frequency of the applied AC increases, the reactance increases
C. As the amplitude of the applied AC increases, the reactance increases
D. As the amplitude of the applied AC increases, the reactance decreases

G5A07

What happens when the impedance of an electrical load is equal to the output impedance of a power source, assuming both impedances are resistive?

- A. The source delivers minimum power to the load
- B. The electrical load is shorted
- C. No current can flow through the circuit
- D. The source can deliver maximum power to the load

G5A07

(D)

Page 4-19

G5A08

Why is impedance matching important?

- A. So the source can deliver maximum power to the load
- B. So the load will draw minimum power from the source
- C. To ensure that there is less resistance than reactance in the circuit
- D. To ensure that the resistance and reactance in the circuit are equal

G5A08

(A)

Page 4-19

G5A09

What unit is used to measure reactance?

- A. Farad
- B. Ohm
- C. Ampere
- D. Siemens

G5A09

(B)

Page 4-16

G5A10

What unit is used to measure impedance?

- A. Volt
- B. Ohm
- C. Ampere
- D. Watt

G5A10

(B)

Page 4-18

G5A11

Which of the following describes one method of impedance matching between two AC circuits?

- A. Insert an LC network between the two circuits
- B. Reduce the power output of the first circuit
- C. Increase the power output of the first circuit
- D. Insert a circulator between the two circuits

G5A11

(A)

Page 4-19

G5A12

What is one reason to use an impedance matching transformer?

- A. To minimize transmitter power output
- B. To maximize the transfer of power
- C. To reduce power supply ripple
- D. To minimize radiation resistance

G5A12

(B)

Page 4-20

G5A13
(D)
Page 4-20

G5A13
Which of the following devices can be used for impedance matching at radio frequencies?
A. A transformer
B. A Pi-network
C. A length of transmission line
D. All of these choices are correct

G5C07
(A)
Page 4-19

G5C07
What is the turns ratio of a transformer used to match an audio amplifier having 600 ohm output impedance to a speaker having 4 ohm impedance?
A. 12.2 to 1
B. 24.4 to 1
C. 150 to 1
D. 300 to 1

Section 4.5

G6A03
(B)
Page 4-20

G6A03
What is the approximate junction threshold voltage of a germanium diode?
A. 0.1 volt
B. 0.3 volts
C. 0.7 volts
D. 1.0 volts

G6A05
(C)
Page 4-20

G6A05
What is the approximate junction threshold voltage of a conventional silicon diode?
A. 0.1 volt
B. 0.3 volts
C. 0.7 volts
D. 1.0 volts

G6A06
(A)
Page 4-21

G6A06
Which of the following is an advantage of using a Schottky diode in an RF switching circuit rather than a standard silicon diode?
A. Lower capacitance
B. Lower inductance
C. Longer switching times
D. Higher breakdown voltage

G6A07
(A)
Page 4-23

G6A07
What are the stable operating points for a bipolar transistor used as a switch in a logic circuit?
A. Its saturation and cutoff regions
B. Its active region (between the cutoff and saturation regions)
C. Its peak and valley current points
D. Its enhancement and depletion modes

G6A08

Why must the cases of some large power transistors be insulated from ground?

- A. To increase the beta of the transistor
- B. To improve the power dissipation capability
- C. To reduce stray capacitance
- D. To avoid shorting the collector or drain voltage to ground

G6A08
(D)
Page 4-23

G6A09

Which of the following describes the construction of a MOSFET?

- A. The gate is formed by a back-biased junction
- B. The gate is separated from the channel with a thin insulating layer
- C. The source is separated from the drain by a thin insulating layer
- D. The source is formed by depositing metal on silicon

G6A09
(B)
Page 4-22

G6A10

Which element of a triode vacuum tube is used to regulate the flow of electrons between cathode and plate?

- A. Control grid
- B. Heater
- C. Screen Grid
- D. Trigger electrode

G6A10
(A)
Page 4-23

G6A11

Which of the following solid state devices is most like a vacuum tube in its general operating characteristics?

- A. A bipolar transistor
- B. A field effect transistor
- C. A tunnel diode
- D. A varistor

G6A11
(B)
Page 4-23

G6A12

What is the primary purpose of a screen grid in a vacuum tube?

- A. To reduce grid-to-plate capacitance
- B. To increase efficiency
- C. To increase the control grid resistance
- D. To decrease plate resistance

G6A12
(A)
Page 4-23

G6B01

Which of the following is an analog integrated circuit?

- A. NAND Gate
- B. Microprocessor
- C. Frequency Counter
- D. Linear voltage regulator

G6B01
(D)
Page 4-24

G6B02

What is meant by the term MMIC?

- A. Multi Megabyte Integrated Circuit
- B. Monolithic Microwave Integrated Circuit
- C. Military Manufactured Integrated Circuit
- D. Mode Modulated Integrated Circuit

G6B02
(B)
Page 4-26

G6B03
(A)
Page 4-24

G6B03

Which of the following is an advantage of CMOS integrated circuits compared to TTL integrated circuits?

- A. Low power consumption
- B. High power handling capability
- C. Better suited for RF amplification
- D. Better suited for power supply regulation

G6B04
(B)
Page 4-27

G6B04

What is meant by the term ROM?

- A. Resistor Operated Memory
- B. Read Only Memory
- C. Random Operational Memory
- D. Resistant to Overload Memory

G6B05
(C)
Page 4-27

G6B05

What is meant when memory is characterized as non-volatile?

- A. It is resistant to radiation damage
- B. It is resistant to high temperatures
- C. The stored information is maintained even if power is removed
- D. The stored information cannot be changed once written

G6B06
(D)
Page 4-24

G6B06

What kind of device is an integrated circuit operational amplifier?

- A. Digital
- B. MMIC
- C. Programmable Logic
- D. Analog

G6B07
(D)
Page 4-28

G6B07

Which of the following is an advantage of an LED indicator compared to an incandescent indicator?

- A. Lower power consumption
- B. Faster response time
- C. Longer life
- D. All of these choices are correct

G6B08
(D)
Page 4-28

G6B08

How is an LED biased when emitting light?

- A. Beyond cutoff
- B. At the Zener voltage
- C. Reverse Biased
- D. Forward Biased

G6B09
(A)
Page 4-28

G6B09

Which of the following is a characteristic of a liquid crystal display?

- A. It requires ambient or back lighting
- B. It offers a wide dynamic range
- C. It has a wide viewing angle
- D. All of these choices are correct

G6B10

What two devices in an Amateur Radio station might be connected using a USB interface?

- A. Computer and transceiver
- B. Microphone and transceiver
- C. Amplifier and antenna
- D. Power supply and amplifier

G6B10

(A)

Page 4-27

G6B11

What is a microprocessor?

- A. A low power analog signal processor used as a microwave detector
- B. A computer on a single integrated circuit
- C. A microwave detector, amplifier, and local oscillator on a single integrated circuit
- D. A low voltage amplifier used in a microwave transmitter modulator stage

G6B11

(B)

Page 4-26

G7B01

Complex digital circuitry can often be replaced by what type of integrated circuit?

- A. Microcontroller
- B. Charge-coupled device
- C. Phase detector
- D. Window comparator

G7B01

(A)

Page 4-26

G7B02

Which of the following is an advantage of using the binary system when processing digital signals?

- A. Binary “ones” and “zeros” are easy to represent by an “on” or “off” state
- B. The binary number system is most accurate
- C. Binary numbers are more compatible with analog circuitry
- D. All of these choices are correct

G7B02

(A)

Page 4-24

G7B03

Which of the following describes the function of a two input AND gate?

- A. Output is high when either or both inputs are low
- B. Output is high only when both inputs are high
- C. Output is low when either or both inputs are high
- D. Output is low only when both inputs are high

G7B03

(B)

Page 4-25

G7B04

Which of the following describes the function of a two input NOR gate?

- A. Output is high when either or both inputs are low
- B. Output is high only when both inputs are high
- C. Output is low when either or both inputs are high
- D. Output is low only when both inputs are high

G7B04

(C)

Page 4-25

G7B05

How many states does a 3-bit binary counter have?

- A. 3
- B. 6
- C. 8
- D. 16

G7B05

(C)

Page 4-26

G7B06
(A)
Page 4-26

- G7B06
- What is a shift register?
- A. A clocked array of circuits that passes data in steps along the array
 - B. An array of operational amplifiers used for tri-state arithmetic operations
 - C. A digital mixer
 - D. An analog mixer

Section 4.6

G4E08
(A)
Page 4-33

- G4E08
- What is the name of the process by which sunlight is changed directly into electricity?
- A. Photovoltaic conversion
 - B. Photon emission
 - C. Photosynthesis
 - D. Photon decomposition

G4E09
(B)
Page 4-33

- G4E09
- What is the approximate open-circuit voltage from a fully illuminated silicon photovoltaic cell?
- A. 0.02 VDC
 - B. 0.5 VDC
 - C. 0.2 VDC
 - D. 1.38 VDC

G4E10
(B)
Page 4-34

- G4E10
- What is the reason that a series diode is connected between a solar panel and a storage battery that is being charged by the panel?
- A. The diode serves to regulate the charging voltage to prevent overcharge
 - B. The diode prevents self-discharge of the battery through the panel during times of low or no illumination
 - C. The diode limits the current flowing from the panel to a safe value
 - D. The diode greatly increases the efficiency during times of high illumination

G4E11
(C)
Page 4-33

- G4E11
- Which of the following is a disadvantage of using wind as the primary source of power for an emergency station?
- A. The conversion efficiency from mechanical energy to electrical energy is less than 2 percent
 - B. The voltage and current ratings of such systems are not compatible with amateur equipment
 - C. A large energy storage system is needed to supply power when the wind is not blowing
 - D. All of these choices are correct

G6A01
(C)
Page 4-32

- G6A01
- What is the minimum allowable discharge voltage for maximum life of a standard 12 volt lead acid battery?
- A. 6 volts
 - B. 8.5 volts
 - C. 10.5 volts
 - D. 12 volts

G6A02

What is an advantage of the low internal resistance of nickel-cadmium batteries?

- A. Long life
- B. High discharge current
- C. High voltage
- D. Rapid recharge

G6A02
(B)
Page 4-33

G6A04

When is it acceptable to recharge a carbon-zinc primary cell?

- A. As long as the voltage has not been allowed to drop below 1.0 volt
- B. When the cell is kept warm during the recharging period
- C. When a constant current charger is used
- D. Never

G6A04
(D)
Page 4-33

G6B12

Which of the following connectors would be a good choice for a serial data port?

- A. PL-259
- B. Type N
- C. Type SMA
- D. DE-9

G6B12
(D)
Page 4-36

G6B13

Which of these connector types is commonly used for RF connections at frequencies up to 150 MHz?

- A. Octal
- B. RJ-11
- C. PL-259
- D. DB-25

G6B13
(C)
Page 4-36

G6B14

Which of these connector types is commonly used for audio signals in Amateur Radio stations?

- A. PL-259
- B. BNC
- C. RCA Phono
- D. Type N

G6B14
(C)
Page 4-35

G6B15

What is the main reason to use keyed connectors instead of non-keyed types?

- A. Prevention of use by unauthorized persons
- B. Reduced chance of incorrect mating
- C. Higher current carrying capacity
- D. All of these choices are correct

G6B15
(B)
Page 4-34

G6B16

Which of the following describes a type N connector?

- A. A moisture-resistant RF connector useful to 10 GHz
- B. A small bayonet connector used for data circuits
- C. A threaded connector used for hydraulic systems
- D. An audio connector used in surround-sound installations

G6B16
(A)
Page 4-36

G6B17
(C)
Page 4-35

G6B17

What is the general description of a DIN type connector?

- A. A special connector for microwave interfacing
- B. A DC power connector rated for currents between 30 and 50 amperes
- C. A family of multiple circuit connectors suitable for audio and control signals
- D. A special watertight connector for use in marine applications

G6B18
(B)
Page 4-36

G6B18

What is a type SMA connector?

- A. A large bayonet connector usable at power levels in excess of 1 KW
- B. A small threaded connector suitable for signals up to several GHz
- C. A connector designed for serial multiple access signals
- D. A type of push-on connector intended for high voltage applications

G7A01
(B)
Page 4-31

G7A01

What useful feature does a power supply bleeder resistor provide?

- A. It acts as a fuse for excess voltage
- B. It ensures that the filter capacitors are discharged when power is removed
- C. It removes shock hazards from the induction coils
- D. It eliminates ground loop current

G7A02
(D)
Page 4-30

G7A02

Which of the following components are used in a power supply filter network?

- A. Diodes
- B. Transformers and transducers
- C. Quartz crystals
- D. Capacitors and inductors

G7A03
(D)
Page 4-30

G7A03

What is the peak-inverse-voltage across the rectifiers in a full-wave bridge power supply?

- A. One-quarter the normal output voltage of the power supply
- B. Half the normal output voltage of the power supply
- C. Double the normal peak output voltage of the power supply
- D. Equal to the normal peak output voltage of the power supply

G7A04
(D)
Page 4-30

G7A04

What is the peak-inverse-voltage across the rectifier in a half-wave power supply?

- A. One-half the normal peak output voltage of the power supply
- B. One-half the normal output voltage of the power supply
- C. Equal to the normal output voltage of the power supply
- D. Two times the normal peak output voltage of the power supply

G7A05
(B)
Page 4-28

G7A05

What portion of the AC cycle is converted to DC by a half-wave rectifier?

- A. 90 degrees
- B. 180 degrees
- C. 270 degrees
- D. 360 degrees

G7A06

What portion of the AC cycle is converted to DC by a full-wave rectifier?

- A. 90 degrees
- B. 180 degrees
- C. 270 degrees
- D. 360 degrees

G7A06

(D)

Page 4-29

G7A07

What is the output waveform of an unfiltered full-wave rectifier connected to a resistive load?

- A. A series of DC pulses at twice the frequency of the AC input
- B. A series of DC pulses at the same frequency as the AC input
- C. A sine wave at half the frequency of the AC input
- D. A steady DC voltage

G7A07

(A)

Page 4-29

G7A08

Which of the following is an advantage of a switchmode power supply as compared to a linear power supply?

- A. Faster switching time makes higher output voltage possible
- B. Fewer circuit components are required
- C. High frequency operation allows the use of smaller components
- D. All of these choices are correct

G7A08

(C)

Page 4-32

Section 4.7

G4B01

What item of test equipment contains horizontal and vertical channel amplifiers?

- A. An ohmmeter
- B. A signal generator
- C. An ammeter
- D. An oscilloscope

G4B01

(D)

Page 4-38

G4B02

Which of the following is an advantage of an oscilloscope versus a digital voltmeter?

- A. An oscilloscope uses less power
- B. Complex impedances can be easily measured
- C. Input impedance is much lower
- D. Complex waveforms can be measured

G4B02

(D)

Page 4-38

G4B03

Which of the following is the best instrument to use when checking the keying waveform of a CW transmitter?

- A. An oscilloscope
- B. A field strength meter
- C. A sidetone monitor
- D. A wavemeter

G4B03

(A)

Page 4-38

<p>G4B04 (D) Page 4-38</p>	<p>G4B04</p> <p>What signal source is connected to the vertical input of an oscilloscope when checking the RF envelope pattern of a transmitted signal?</p> <ul style="list-style-type: none"> A. The local oscillator of the transmitter B. An external RF oscillator C. The transmitter balanced mixer output D. The attenuated RF output of the transmitter
<p>G4B05 (D) Page 4-38</p>	<p>G4B05</p> <p>Why is high input impedance desirable for a voltmeter?</p> <ul style="list-style-type: none"> A. It improves the frequency response B. It decreases battery consumption in the meter C. It improves the resolution of the readings D. It decreases the loading on circuits being measured
<p>G4B06 (C) Page 4-37</p>	<p>G4B06</p> <p>What is an advantage of a digital voltmeter as compared to an analog voltmeter?</p> <ul style="list-style-type: none"> A. Better for measuring computer circuits B. Better for RF measurements C. Better precision for most uses D. Faster response
<p>G4B08 (A) Page 4-39</p>	<p>G4B08</p> <p>Which of the following instruments may be used to monitor relative RF output when making antenna and transmitter adjustments?</p> <ul style="list-style-type: none"> A. A field strength meter B. An antenna noise bridge C. A multimeter D. A Q meter
<p>G4B09 (B) Page 4-39</p>	<p>G4B09</p> <p>Which of the following can be determined with a field strength meter?</p> <ul style="list-style-type: none"> A. The radiation resistance of an antenna B. The radiation pattern of an antenna C. The presence and amount of phase distortion of a transmitter D. The presence and amount of amplitude distortion of a transmitter
<p>G4B10 (A) Page 4-40</p>	<p>G4B10</p> <p>Which of the following can be determined with a directional wattmeter?</p> <ul style="list-style-type: none"> A. Standing wave ratio B. Antenna front-to-back ratio C. RF interference D. Radio wave propagation

G4B11

Which of the following must be connected to an antenna analyzer when it is being used for SWR measurements?

- A. Receiver
- B. Transmitter
- C. Antenna and feed line
- D. All of these choices are correct

G4B11

(C)

Page 4-39

G4B12

What problem can occur when making measurements on an antenna system with an antenna analyzer?

- A. Permanent damage to the analyzer may occur if it is operated into a high SWR
- B. Strong signals from nearby transmitters can affect the accuracy of measurements
- C. The analyzer can be damaged if measurements outside the ham bands are attempted
- D. Connecting the analyzer to an antenna can cause it to absorb harmonics

G4B12

(B)

Page 4-39

G4B13

What is a use for an antenna analyzer other than measuring the SWR of an antenna system?

- A. Measuring the front to back ratio of an antenna
- B. Measuring the turns ratio of a power transformer
- C. Determining the impedance of an unknown or unmarked coaxial cable
- D. Determining the gain of a directional antenna

G4B13

(C)

Page 4-39

G4B14

What is an instance in which the use of an instrument with analog readout may be preferred over an instrument with a digital readout?

- A. When testing logic circuits
- B. When high precision is desired
- C. When measuring the frequency of an oscillator
- D. When adjusting tuned circuits

G4B14

(D)

Page 4-37

Chapter 5

Section 5.1

G8A02

What is the name of the process that changes the phase angle of an RF wave to convey information?

- A. Phase convolution
- B. Phase modulation
- C. Angle convolution
- D. Radian inversion

G8A02

(B)

Page 5-2

G8A03

What is the name of the process that changes the instantaneous frequency of an RF wave to convey information?

- A. Frequency convolution
- B. Frequency transformation
- C. Frequency conversion
- D. Frequency modulation

G8A03

(D)

Page 5-2

G8A05
(D)
Page 5-2

G8A05
What type of modulation varies the instantaneous power level of the RF signal?
A. Frequency shift keying
B. Phase modulation
C. Frequency modulation
D. Amplitude modulation

G8A07
(A)
Page 5-2

G8A07
Which of the following phone emissions uses the narrowest bandwidth?
A. Single sideband
B. Double sideband
C. Phase modulation
D. Frequency modulation

Section 5.2

G4D08
(C)
Page 5-5

G4D08
What frequency range is occupied by a 3 kHz LSB signal when the displayed carrier frequency is set to 7.178 MHz?
A. 7.178 to 7.181 MHz
B. 7.178 to 7.184 MHz
C. 7.175 to 7.178 MHz
D. 7.1765 to 7.1795 MHz

G4D09
(B)
Page 5-5

G4D09
What frequency range is occupied by a 3 kHz USB signal with the displayed carrier frequency set to 14.347 MHz?
A. 14.347 to 14.647 MHz
B. 14.347 to 14.350 MHz
C. 14.344 to 14.347 MHz
D. 14.3455 to 14.3485 MHz

G4D10
(A)
Page 5-5

G4D10
How close to the lower edge of the 40-meter General Class phone segment should your displayed carrier frequency be when using 3 kHz wide LSB?
A. At least 3 kHz above the edge of the segment
B. At least 3 kHz below the edge of the segment
C. Your displayed carrier frequency may be set at the edge of the segment
D. At least 1 kHz above the edge of the segment

G4D11
(B)
Page 5-5

G4D11
How close to the upper edge of the 20-meter General Class band should your displayed carrier frequency be when using 3 kHz wide USB?
A. At least 3 kHz above the edge of the band
B. At least 3 kHz below the edge of the band
C. Your displayed carrier frequency may be set at the edge of the band
D. At least 1 kHz below the edge of the segment

G7B07

What are the basic components of virtually all sine wave oscillators?

- A. An amplifier and a divider
- B. A frequency multiplier and a mixer
- C. A circulator and a filter operating in a feed-forward loop
- D. A filter and an amplifier operating in a feedback loop

G7B07

(D)

Page 5-3

G7B09

What determines the frequency of an LC oscillator?

- A. The number of stages in the counter
- B. The number of stages in the divider
- C. The inductance and capacitance in the tank circuit
- D. The time delay of the lag circuit

G7B09

(C)

Page 5-3

G7C05

Which of the following is an advantage of a transceiver controlled by a direct digital synthesizer (DDS)?

- A. Wide tuning range and no need for band switching
- B. Relatively high power output
- C. Relatively low power consumption
- D. Variable frequency with the stability of a crystal oscillator

G7C05

(D)

Page 5-4

G8A04

What emission is produced by a reactance modulator connected to a transmitter RF amplifier stage?

- A. Multiplex modulation
- B. Phase modulation
- C. Amplitude modulation
- D. Pulse modulation

G8A04

(B)

Page 5-6

G8A06

What is one advantage of carrier suppression in a single sideband phone transmission versus full carrier amplitude modulation?

- A. Audio fidelity is improved
- B. Greater modulation percentage is obtainable with lower distortion
- C. Available transmitter power can be used more effectively
- D. Simpler receiving equipment can be used

G8A06

(C)

Page 5-6

G8B01

What receiver stage combines a 14.250 MHz input signal with a 13.795 MHz oscillator signal to produce a 455 kHz intermediate frequency (IF) signal?

- A. Mixer
- B. BFO
- C. VFO
- D. Discriminator

G8B01

(A)

Page 5-4

G8B03
(A)
Page 5-4

G8B03
What is another term for the mixing of two RF signals?
A. Heterodyning
B. Synthesizing
C. Cancellation
D. Phase inverting

G8B04
(D)
Page 5-4

G8B04
What is the stage in a VHF FM transmitter that generates a harmonic of a lower frequency signal to reach the desired operating frequency?
A. Mixer
B. Reactance modulator
C. Pre-emphasis network
D. Multiplier

Section 5.3

G4A03
(C)
Page 5-8

G4A03
What is normally meant by operating a transceiver in “split” mode?
A. The radio is operating at half power
B. The transceiver is operating from an external power source
C. The transceiver is set to different transmit and receive frequencies
D. The transmitter is emitting an SSB signal, as opposed to DSB operation

G4A04
(B)
Page 5-13

G4A04
What reading on the plate current meter of a vacuum tube RF power amplifier indicates correct adjustment of the plate tuning control?
A. A pronounced peak
B. A pronounced dip
C. No change will be observed
D. A slow, rhythmic oscillation

G4A05
(C)
Page 5-13

G4A05
What is a reason to use Automatic Level Control (ALC) with an RF power amplifier?
A. To balance the transmitter audio frequency response
B. To reduce harmonic radiation
C. To reduce distortion due to excessive drive
D. To increase overall efficiency

G4A07
(D)
Page 5-13

G4A07
What condition can lead to permanent damage to a solid-state RF power amplifier?
A. Insufficient drive power
B. Low input SWR
C. Shorting the input signal to ground
D. Excessive drive power

G4A08

What is the correct adjustment for the load or coupling control of a vacuum tube RF power amplifier?

- A. Minimum SWR on the antenna
- B. Minimum plate current without exceeding maximum allowable grid current
- C. Highest plate voltage while minimizing grid current
- D. Maximum power output without exceeding maximum allowable plate current

G4A08
(D)
Page 5-13

G4A09

Why is a time delay sometimes included in a transmitter keying circuit?

- A. To prevent stations from interfering with one another
- B. To allow the transmitter power regulators to charge properly
- C. To allow time for transmit-receive changeover operations to complete properly before RF output is allowed
- D. To allow time for a warning signal to be sent to other stations

G4A09
(C)
Page 5-13

G4A12

Which of the following is a common use for the dual VFO feature on a transceiver?

- A. To allow transmitting on two frequencies at once
- B. To permit full duplex operation, that is transmitting and receiving at the same time
- C. To permit monitoring of two different frequencies
- D. To facilitate computer interface

G4A12
(C)
Page 5-8

G4B07

What signals are used to conduct a two-tone test?

- A. Two audio signals of the same frequency shifted 90 degrees
- B. Two non-harmonically related audio signals
- C. Two swept frequency tones
- D. Two audio frequency range square wave signals of equal amplitude

G4B07
(B)
Page 5-11

G4B15

What type of transmitter performance does a two-tone test analyze?

- A. Linearity
- B. Percentage of suppression of carrier and undesired sideband for SSB
- C. Percentage of frequency modulation
- D. Percentage of carrier phase shift

G4B15
(A)
Page 5-11

G4D01

What is the purpose of a speech processor as used in a modern transceiver?

- A. Increase the intelligibility of transmitted phone signals during poor conditions
- B. Increase transmitter bass response for more natural sounding SSB signals
- C. Prevent distortion of voice signals
- D. Decrease high-frequency voice output to prevent out of band operation

G4D01
(A)
Page 5-11

<p>G4D02 (B) Page 5-11</p>	<p>G4D02 Which of the following describes how a speech processor affects a transmitted single sideband phone signal? A. It increases peak power B. It increases average power C. It reduces harmonic distortion D. It reduces intermodulation distortion</p>
<p>G4D03 (D) Page 5-11</p>	<p>G4D03 Which of the following can be the result of an incorrectly adjusted speech processor? A. Distorted speech B. Splatter C. Excessive background pickup D. All of these choices are correct</p>
<p>G7B08 (B) Page 5-13</p>	<p>G7B08 How is the efficiency of an RF power amplifier determined? A. Divide the DC input power by the DC output power B. Divide the RF output power by the DC input power C. Multiply the RF input power by the reciprocal of the RF output power D. Add the RF input power to the DC output power</p>
<p>G7B10 (D) Page 5-12</p>	<p>G7B10 Which of the following is a characteristic of a Class A amplifier? A. Low standby power B. High Efficiency C. No need for bias D. Low distortion</p>
<p>G7B11 (B) Page 5-13</p>	<p>G7B11 For which of the following modes is a Class C power stage appropriate for amplifying a modulated signal? A. SSB B. CW C. AM D. All of these choices are correct</p>
<p>G7B12 (D) Page 5-13</p>	<p>G7B12 Which of these classes of amplifiers has the highest efficiency? A. Class A B. Class B C. Class AB D. Class C</p>
<p>G7B13 (B) Page 5-14</p>	<p>G7B13 What is the reason for neutralizing the final amplifier stage of a transmitter? A. To limit the modulation index B. To eliminate self-oscillations C. To cut off the final amplifier during standby periods D. To keep the carrier on frequency</p>

G7B14

Which of the following describes a linear amplifier?

- A. Any RF power amplifier used in conjunction with an amateur transceiver
- B. An amplifier in which the output preserves the input waveform
- C. A Class C high efficiency amplifier
- D. An amplifier used as a frequency multiplier

G7B14

(B)

Page 5-12

G7C01

Which of the following is used to process signals from the balanced modulator then send them to the mixer in some single sideband phone transmitters?

- A. Carrier oscillator
- B. Filter
- C. IF amplifier
- D. RF amplifier

G7C01

(B)

Page 5-8

G7C02

Which circuit is used to combine signals from the carrier oscillator and speech amplifier then send the result to the filter in some single sideband phone transmitters?

- A. Discriminator
- B. Detector
- C. IF amplifier
- D. Balanced modulator

G7C02

(D)

Page 5-8

G8A08

Which of the following is an effect of overmodulation?

- A. Insufficient audio
- B. Insufficient bandwidth
- C. Frequency drift
- D. Excessive bandwidth

G8A08

(D)

Page 5-12

G8A09

What control is typically adjusted for proper ALC setting on an amateur single sideband transceiver?

- A. The RF clipping level
- B. Transmit audio or microphone gain
- C. Antenna inductance or capacitance
- D. Attenuator level

G8A09

(B)

Page 5-11

G8A10

What is meant by the term flat-topping when referring to a single sideband phone transmission?

- A. Signal distortion caused by insufficient collector current
- B. The transmitter's automatic level control (ALC) is properly adjusted
- C. Signal distortion caused by excessive drive
- D. The transmitter's carrier is properly suppressed

G8A10

(C)

Page 5-11

G8A11
(A)
Page 5-10

G8A11
What is the modulation envelope of an AM signal?
A. The waveform created by connecting the peak values of the modulated signal
B. The carrier frequency that contains the signal
C. Spurious signals that envelop nearby frequencies
D. The bandwidth of the modulated signal

G8B06
(D)
Page 5-9

G8B06
What is the total bandwidth of an FM phone transmission having 5 kHz deviation and 3 kHz modulating frequency?
A. 3 kHz
B. 5 kHz
C. 8 kHz
D. 16 kHz

G8B07
(B)
Page 5-9

G8B07
What is the frequency deviation for a 12.21 MHz reactance modulated oscillator in a 5 kHz deviation, 146.52 MHz FM phone transmitter?
A. 101.75 Hz
B. 416.7 Hz
C. 5 kHz
D. 60 kHz

Section 5.4

G4A01
(B)
Page 5-16

G4A01
What is the purpose of the “notch filter” found on many HF transceivers?
A. To restrict the transmitter voice bandwidth
B. To reduce interference from carriers in the receiver passband
C. To eliminate receiver interference from impulse noise sources
D. To enhance the reception of a specific frequency on a crowded band

G4A02
(C)
Page 5-16

G4A02
What is one advantage of selecting the opposite or “reverse” sideband when receiving CW signals on a typical HF transceiver?
A. Interference from impulse noise will be eliminated
B. More stations can be accommodated within a given signal passband
C. It may be possible to reduce or eliminate interference from other signals
D. Accidental out of band operation can be prevented

G4A11
(A)
Page 5-16

G4A11
Which of the following is a use for the IF shift control on a receiver?
A. To avoid interference from stations very close to the receive frequency
B. To change frequency rapidly
C. To permit listening on a different frequency from that on which you are transmitting
D. To tune in stations that are slightly off frequency without changing your transmit frequency

G4A13

What is one reason to use the attenuator function that is present on many HF transceivers?

- A. To reduce signal overload due to strong incoming signals
- B. To reduce the transmitter power when driving a linear amplifier
- C. To reduce power consumption when operating from batteries
- D. To slow down received CW signals for better copy

G4A13

(A)

Page 5-18

G4C11

Which of the following is a function of a digital signal processor?

- A. To provide adequate grounding
- B. To remove noise from received signals
- C. To increase antenna gain
- D. To increase antenna bandwidth

G4C11

(B)

Page 5-17

G4C12

Which of the following is an advantage of a receiver DSP IF filter as compared to an analog filter?

- A. A wide range of filter bandwidths and shapes can be created
- B. Fewer digital components are required
- C. Mixing products are greatly reduced
- D. The DSP filter is much more effective at VHF frequencies

G4C12

(A)

Page 5-17

G4C13

Which of the following can perform automatic notching of interfering carriers?

- A. Bandpass tuning
- B. A Digital Signal Processor (DSP) filter
- C. Balanced mixing
- D. A noise limiter

G4C13

(B)

Page 5-17

G4D04

What does an S meter measure?

- A. Conductance
- B. Impedance
- C. Received signal strength
- D. Transmitter power output

G4D04

(C)

Page 5-18

G4D05

How does a signal that reads 20 dB over S9 compare to one that reads S9 on a receiver, assuming a properly calibrated S meter?

- A. It is 10 times less powerful
- B. It is 20 times less powerful
- C. It is 20 times more powerful
- D. It is 100 times more powerful

G4D05

(D)

Page 5-18

G4D06

Where is an S meter found?

- A. In a receiver
- B. In an SWR bridge
- C. In a transmitter
- D. In a conductance bridge

G4D06

(A)

Page 5-18

G4D07
(C)
Page 5-18

G4D07

How much must the power output of a transmitter be raised to change the S meter reading on a distant receiver from S8 to S9?

- A. Approximately 1.5 times
- B. Approximately 2 times
- C. Approximately 4 times
- D. Approximately 8 times

G7C03
(C)
Page 5-14

G7C03

What circuit is used to process signals from the RF amplifier and local oscillator then send the result to the IF filter in a superheterodyne receiver?

- A. Balanced modulator
- B. IF amplifier
- C. Mixer
- D. Detector

G7C04
(D)
Page 5-15

G7C04

What circuit is used to combine signals from the IF amplifier and BFO and send the result to the AF amplifier in some single sideband receivers?

- A. RF oscillator
- B. IF filter
- C. Balanced modulator
- D. Product detector

G7C07
(C)
Page 5-14

G7C07

What is the simplest combination of stages that implement a superheterodyne receiver?

- A. RF amplifier, detector, audio amplifier
- B. RF amplifier, mixer, IF discriminator
- C. HF oscillator, mixer, detector
- D. HF oscillator, prescaler, audio amplifier

G7C08
(D)
Page 5-15

G7C08

What type of circuit is used in many FM receivers to convert signals coming from the IF amplifier to audio?

- A. Product detector
- B. Phase inverter
- C. Mixer
- D. Discriminator

G7C09
(D)
Page 5-16

G7C09

Which of the following is needed for a Digital Signal Processor IF filter?

- A. An analog to digital converter
- B. A digital to analog converter
- C. A digital processor chip
- D. All of the these choices are correct

G7C10

How is Digital Signal Processor filtering accomplished?

- A. By using direct signal phasing
- B. By converting the signal from analog to digital and using digital processing
- C. By differential spurious phasing
- D. By converting the signal from digital to analog and taking the difference of mixing products

G7C10
(B)
Page 5-16

G7C11

What is meant by the term “software defined radio” (SDR)?

- A. A radio in which most major signal processing functions are performed by software
- B. A radio that provides computer interface for automatic logging of band and frequency
- C. A radio that uses crystal filters designed using software
- D. A computer model that can simulate performance of a radio to aid in the design process

G7C11
(A)
Page 5-17

G8B02

If a receiver mixes a 13.800 MHz VFO with a 14.255 MHz received signal to produce a 455 kHz intermediate frequency (IF) signal, what type of interference will a 13.345 MHz signal produce in the receiver?

- A. Quadrature noise
- B. Image response
- C. Mixer interference
- D. Intermediate interference

G8B02
(B)
Page 5-16

G8B09

Why is it good to match receiver bandwidth to the bandwidth of the operating mode?

- A. It is required by FCC rules
- B. It minimizes power consumption in the receiver
- C. It improves impedance matching of the antenna
- D. It results in the best signal to noise ratio

G8B09
(D)
Page 5-16

Section 5.5

G4A15

Which of the following can be a symptom of transmitted RF being picked up by an audio cable carrying AFSK data signals between a computer and a transceiver?

- A. The VOX circuit does not un-key the transmitter
- B. The transmitter signal is distorted
- C. Frequent connection timeouts
- D. All of these choices are correct

G4A15
(D)
Page 5-20

G4C01

Which of the following might be useful in reducing RF interference to audio frequency devices?

- A. Bypass inductor
- B. Bypass capacitor
- C. Forward-biased diode
- D. Reverse-biased diode

G4C01
(B)
Page 5-22

G4C02
(C)
Page 5-22

G4C02
Which of the following could be a cause of interference covering a wide range of frequencies?
A. Not using a balun or line isolator to feed balanced antennas
B. Lack of rectification of the transmitter's signal in power conductors
C. Arcing at a poor electrical connection
D. Using a balun to feed an unbalanced antenna

G4C03
(C)
Page 5-22

G4C03
What sound is heard from an audio device or telephone if there is interference from a nearby single sideband phone transmitter?
A. A steady hum whenever the transmitter is on the air
B. On-and-off humming or clicking
C. Distorted speech
D. Clearly audible speech

G4C04
(A)
Page 5-22

G4C04
What is the effect on an audio device or telephone system if there is interference from a nearby CW transmitter?
A. On-and-off humming or clicking
B. A CW signal at a nearly pure audio frequency
C. A chirpy CW signal
D. Severely distorted audio

G4C05
(D)
Page 5-21

G4C05
What might be the problem if you receive an RF burn when touching your equipment while transmitting on an HF band, assuming the equipment is connected to a ground rod?
A. Flat braid rather than round wire has been used for the ground wire
B. Insulated wire has been used for the ground wire
C. The ground rod is resonant
D. The ground wire has high impedance on that frequency

G4C06
(C)
Page 5-21

G4C06
What effect can be caused by a resonant ground connection?
A. Overheating of ground straps
B. Corrosion of the ground rod
C. High RF voltages on the enclosures of station equipment
D. A ground loop

G4C07
(A)
Page 5-20

G4C07
What is one good way to avoid unwanted effects of stray RF energy in an amateur station?
A. Connect all equipment grounds together
B. Install an RF filter in series with the ground wire
C. Use a ground loop for best conductivity
D. Install a few ferrite beads on the ground wire where it connects to your station

G4C08

Which of the following would reduce RF interference caused by common-mode current on an audio cable?

- A. Placing a ferrite choke around the cable
- B. Adding series capacitors to the conductors
- C. Adding shunt inductors to the conductors
- D. Adding an additional insulating jacket to the cable

G4C08
(A)
Page 5-22

G4C09

How can a ground loop be avoided?

- A. Connect all ground conductors in series
- B. Connect the AC neutral conductor to the ground wire
- C. Avoid using lock washers and star washers when making ground connections
- D. Connect all ground conductors to a single point

G4C09
(D)
Page 5-21

G4C10

What could be a symptom of a ground loop somewhere in your station?

- A. You receive reports of “hum” on your station’s transmitted signal
- B. The SWR reading for one or more antennas is suddenly very high
- C. An item of station equipment starts to draw excessive amounts of current
- D. You receive reports of harmonic interference from your station

G4C10
(A)
Page 5-21

G4E03

Which of the following direct, fused power connections would be the best for a 100 watt HF mobile installation?

- A. To the battery using heavy gauge wire
- B. To the alternator or generator using heavy gauge wire
- C. To the battery using resistor wire
- D. To the alternator or generator using resistor wire

G4E03
(A)
Page 5-19

G4E04

Why is it best NOT to draw the DC power for a 100 watt HF transceiver from a vehicle’s auxiliary power socket?

- A. The socket is not wired with an RF-shielded power cable
- B. The socket’s wiring may be inadequate for the current drawn by the transceiver
- C. The DC polarity of the socket is reversed from the polarity of modern HF transceivers
- D. Drawing more than 50 watts from this socket could cause the engine to overheat

G4E04
(B)
Page 5-19

G4E05

Which of the following most limits the effectiveness of an HF mobile transceiver operating in the 75-meter band?

- A. “Picket Fencing” signal variation
- B. The wire gauge of the DC power line to the transceiver
- C. The antenna system
- D. FCC rules limiting mobile output power on the 75-meter band

G4E05
(C)
Page 5-19

G4E07
(D)
Page 5-20

G4E07
Which of the following may cause interference to be heard in the receiver of an HF radio installed in a recent model vehicle?
A. The battery charging system
B. The fuel delivery system
C. The vehicle control computer
D. All of these choices are correct

G7C06
(B)
Page 5-21

G7C06
What should be the impedance of a low-pass filter as compared to the impedance of the transmission line into which it is inserted?
A. Substantially higher
B. About the same
C. Substantially lower
D. Twice the transmission line impedance

Chapter 6

Section 6.1

G2E04
(B)
Page 6-1

G2E04
What segment of the 20-meter band is most often used for digital transmissions?
A. 14.000 – 14.050 MHz
B. 14.070 – 14.100 MHz
C. 14.150 – 14.225 MHz
D. 14.275 – 14.350 MHz

G2E07
(A)
Page 6-1

G2E07
What segment of the 80-meter band is most commonly used for digital transmissions?
A. 3570 – 3600 kHz
B. 3500 – 3525 kHz
C. 3700 – 3750 kHz
D. 3775 – 3825 kHz

G2E08
(D)
Page 6-1

G2E08
In what segment of the 20-meter band are most PSK31 operations commonly found?
A. At the bottom of the slow-scan TV segment, near 14.230 MHz
B. At the top of the SSB phone segment, near 14.325 MHz
C. In the middle of the CW segment, near 14.100 MHz
D. Below the RTTY segment, near 14.070 MHz

G2E13
(A)
Page 6-2

G2E13
Which communication system sometimes uses the Internet to transfer messages?
A. Winlink
B. RTTY
C. ARES
D. Skywarn

G8C01

Which of the following digital modes is designed to operate at extremely low signal strength on the HF bands?

- A. FSK441 and Hellschreiber
- B. JT9 and JT65
- C. Clover
- D. RTTY

G8C01
(B)
Page 6-3

Section 6.2

G8A01

How is an FSK signal generated?

- A. By keying an FM transmitter with a sub-audible tone
- B. By changing an oscillator's frequency directly with a digital control signal
- C. By using a transceiver's computer data interface protocol to change frequencies
- D. By reconfiguring the CW keying input to act as a tone generator

G8A01
(B)
Page 6-5

G8C11

How are the two separate frequencies of a Frequency Shift Keyed (FSK) signal identified?

- A. Dot and Dash
- B. On and Off
- C. High and Low
- D. Mark and Space

G8C11
(D)
Page 6-5

Section 6.3

G2E06

What is the most common frequency shift for RTTY emissions in the amateur HF bands?

- A. 85 Hz
- B. 170 Hz
- C. 425 Hz
- D. 850 Hz

G2E06
(B)
Page 6-6

G8C02

How many data bits are sent in a single PSK31 character?

- A. The number varies
- B. 5
- C. 7
- D. 8

G8C02
(A)
Page 6-7

G8C04

Which of the following describes Baudot code?

- A. A 7-bit code with start, stop and parity bits
- B. A code using error detection and correction
- C. A 5-bit code with additional start and stop bits
- D. A code using SELCAL and LISTEN

G8C04
(C)
Page 6-6

G8C08
(B)
Page 6-7

G8C08
Which of the following statements is true about PSK31?
A. Upper case letters make the signal stronger
B. Upper case letters use longer Varicode signals and thus slow down transmission
C. Varicode Error Correction is used to ensure accurate message reception
D. Higher power is needed as compared to RTTY for similar error rates

G8C09
(A)
Page 6-6

G8C09
What does the number 31 represent in “PSK31”?
A. The approximate transmitted symbol rate
B. The version of the PSK protocol
C. The year in which PSK31 was invented
D. The number of characters that can be represented by PSK31

G8C12
(A)
Page 6-7

G8C12
Which type of code is used for sending characters in a PSK31 signal?
A. Varicode
B. Viterbi
C. Volumetric
D. Binary

Section 6.4

G2E02
(B)
Page 6-8

G2E02
How can a PACTOR modem or controller be used to determine if the channel is in use by other PACTOR stations?
A. Unplug the data connector temporarily and see if the channel-busy indication is turned off
B. Put the modem or controller in a mode which allows monitoring communications without a connection
C. Transmit UI packets several times and wait to see if there is a response from another PACTOR station
D. Send the message: “Is this frequency in use?”

G2E09
(C)
Page 6-8

G2E09
How do you join a contact between two stations using the PACTOR protocol?
A. Send broadcast packets containing your call sign while in MONITOR mode
B. Transmit a steady carrier until the PACTOR protocol times out and disconnects
C. Joining an existing contact is not possible, PACTOR connections are limited to two stations
D. Send a NAK response continuously so that the sending station has to pause

G8C03
(C)
Page 6-7

G8C03
What part of a data packet contains the routing and handling information?
A. Directory
B. Preamble
C. Header
D. Footer

G8C05

In the PACTOR protocol, what is meant by an NAK response to a transmitted packet?

- A. The receiver is requesting the packet be retransmitted
- B. The receiver is reporting the packet was received without error
- C. The receiver is busy decoding the packet
- D. The entire file has been received correctly

G8C05
(A)
Page 6-8

G8C07

How does the receiving station respond to an ARQ data mode packet containing errors?

- A. It terminates the contact
- B. It requests the packet be retransmitted
- C. It sends the packet back to the transmitting station
- D. It requests a change in transmitting protocol

G8C07
(B)
Page 6-8

G8C10

How does forward error correction (FEC) allow the receiver to correct errors in received data packets?

- A. By controlling transmitter output power for optimum signal strength
- B. By using the varicode character set
- C. By transmitting redundant information with the data
- D. By using a parity bit with each character

G8C10
(C)
Page 6-8

Section 6.5

G2E01

Which mode is normally used when sending an RTTY signal via AFSK with an SSB transmitter?

- A. USB
- B. DSB
- C. CW
- D. LSB

G2E01
(D)
Page 6-9

G2E05

What is the standard sideband used to generate a JT65 or JT9 digital signal when using AFSK in any amateur band?

- A. LSB
- B. USB
- C. DSB
- D. SSB

G2E05
(B)
Page 6-9

G2E11

What is indicated on a waterfall display by one or more vertical lines adjacent to a PSK31 signal?

- A. Long Path propagation
- B. Backscatter propagation
- C. Insufficient modulation
- D. Overmodulation

G2E11
(D)
Page 6-11

G2E14
(D)
Page 6-9

G2E14

What could be wrong if you cannot decode an RTTY or other FSK signal even though it is apparently tuned in properly?

- A. The mark and space frequencies may be reversed
- B. You may have selected the wrong baud rate
- C. You may be listening on the wrong sideband
- D. All of these choices are correct

G4A14
(B)
Page 6-11

G4A14

What is likely to happen if a transceiver's ALC system is not set properly when transmitting AFSK signals with the radio using single sideband mode?

- A. ALC will invert the modulation of the AFSK mode
- B. Improper action of ALC distorts the signal and can cause spurious emissions
- C. When using digital modes, too much ALC activity can cause the transmitter to overheat
- D. All of these choices are correct

G8B05
(D)
Page 6-9

G8B05

What is the approximate bandwidth of a PACTOR3 signal at maximum data rate?

- A. 31.5 Hz
- B. 500 Hz
- C. 1800 Hz
- D. 2300 Hz

G8B08
(B)
Page 6-10

G8B08

Why is it important to know the duty cycle of the mode you are using when transmitting?

- A. To aid in tuning your transmitter
- B. Some modes have high duty cycles which could exceed the transmitter's average power rating.
- C. To allow time for the other station to break in during a transmission
- D. All of these choices are correct

G8B10
(B)
Page 6-9

G8B10

What is the relationship between transmitted symbol rate and bandwidth?

- A. Symbol rate and bandwidth are not related
- B. Higher symbol rates require wider bandwidth
- C. Lower symbol rates require wider bandwidth
- D. Bandwidth is always half the symbol rate

Section 6.6

G1E03
(A)
[97.221]
Page 6-12

G1E03

What is required to conduct communications with a digital station operating under automatic control outside the automatic control band segments?

- A. The station initiating the contact must be under local or remote control
- B. The interrogating transmission must be made by another automatically controlled station
- C. No third party traffic maybe be transmitted
- D. The control operator of the interrogating station must hold an Extra Class license

G1E11

Which of the following is the FCC term for an unattended digital station that transfers messages to and from the Internet?

- A. Locally controlled station
- B. Robotically controlled station
- C. Automatically controlled digital station
- D. Fail-safe digital station

G1E11
(C)
[97.221]
Page 6-12

G1E12

Under what circumstances are messages that are sent via digital modes exempt from Part 97 third party rules that apply to other modes of communication?

- A. Under no circumstances
- B. When messages are encrypted
- C. When messages are not encrypted
- D. When under automatic control

G1E12
(A)
[97.115]
Page 6-12

G1E13

On what bands may automatically controlled stations transmitting RTTY or data emissions communicate with other automatically controlled digital stations?

- A. On any band segment where digital operation is permitted
- B. Anywhere in the non-phone segments of the 10-meter or shorter wavelength bands
- C. Only in the non-phone Extra Class segments of the bands
- D. Anywhere in the 1.25-meter or shorter wavelength bands, and in specified segments of the 80-meter through 2-meter bands

G1E13
(D)
[97.221,
97.305]
Page 6-13

G2E03

What symptoms may result from other signals interfering with a PACTOR or WINMOR transmission?

- A. Frequent retries or timeouts
- B. Long pauses in message transmission
- C. Failure to establish a connection between stations
- D. All of these choices are correct

G2E03
(D)
Page 6-13

G2E10

Which of the following is a way to establish contact with a digital messaging system gateway station?

- A. Send an email to the system control operator
- B. Send QRL in Morse code
- C. Respond when the station broadcasts its SSID
- D. Transmit a connect message on the station's published frequency

G2E10
(D)
Page 6-12

G2E12

Which of the following describes a waterfall display?

- A. Frequency is horizontal, signal strength is vertical, time is intensity
- B. Frequency is vertical, signal strength is intensity, time is horizontal
- C. Frequency is horizontal, signal strength is intensity, time is vertical
- D. Frequency is vertical, signal strength is horizontal, time is intensity

G2E12
(C)
Page 6-12

G8C06
(B)
Page 6-13

G8C06

What action results from a failure to exchange information due to excessive transmission attempts when using PACTOR or WINMOR?

- A. The checksum overflows
- B. The connection is dropped
- C. Packets will be routed incorrectly
- D. Encoding reverts to the default character set

Chapter 7

Section 7.1

No questions

Section 7.2

G4E01
(C)
Page 7-5

G4E01

What is the purpose of a capacitance hat on a mobile antenna?

- A. To increase the power handling capacity of a whip antenna
- B. To allow automatic band changing
- C. To electrically lengthen a physically short antenna
- D. To allow remote tuning

G4E02
(D)
Page 7-5

G4E02

What is the purpose of a corona ball on a HF mobile antenna?

- A. To narrow the operating bandwidth of the antenna
- B. To increase the “Q” of the antenna
- C. To reduce the chance of damage if the antenna should strike an object
- D. To reduce high voltage discharge from the tip of the antenna

G4E06
(C)
Page 7-5

G4E06

What is one disadvantage of using a shortened mobile antenna as opposed to a full size antenna?

- A. Short antennas are more likely to cause distortion of transmitted signals
- B. Short antennas can only receive circularly polarized signals
- C. Operating bandwidth may be very limited
- D. Harmonic radiation may increase

G9B01
(B)
Page 7-5

G9B01

What is one disadvantage of a directly fed random-wire HF antenna?

- A. It must be longer than 1 wavelength
- B. You may experience RF burns when touching metal objects in your station
- C. It produces only vertically polarized radiation
- D. It is more effective on the lower HF bands than on the higher bands

G9B02

Which of the following is a common way to adjust the feed point impedance of a quarter wave ground plane vertical antenna to be approximately 50 ohms?

- A. Slope the radials upward
- B. Slope the radials downward
- C. Lengthen the radials
- D. Shorten the radials

G9B02

(B)

Page 7-4

G9B03

What happens to the feed point impedance of a ground plane antenna when its radials are changed from horizontal to sloping downward?

- A. It decreases
- B. It increases
- C. It stays the same
- D. It reaches a maximum at an angle of 45 degrees

G9B03

(B)

Page 7-4

G9B04

What is the radiation pattern of a dipole antenna in free space in the plane of the conductor?

- A. It is a figure-eight at right angles to the antenna
- B. It is a figure-eight off both ends of the antenna
- C. It is a circle (equal radiation in all directions)
- D. It has a pair of lobes on one side of the antenna and a single lobe on the other side

G9B04

(A)

Page 7-2

G9B05

How does antenna height affect the horizontal (azimuthal) radiation pattern of a horizontal dipole HF antenna?

- A. If the antenna is too high, the pattern becomes unpredictable
- B. Antenna height has no effect on the pattern
- C. If the antenna is less than 1/2 wavelength high, the azimuthal pattern is almost omnidirectional
- D. If the antenna is less than 1/2 wavelength high, radiation off the ends of the wire is eliminated

G9B05

(C)

Page 7-6

G9B06

Where should the radial wires of a ground-mounted vertical antenna system be placed?

- A. As high as possible above the ground
- B. Parallel to the antenna element
- C. On the surface of the Earth or buried a few inches below the ground
- D. At the center of the antenna

G9B06

(C)

Page 7-4

G9B07

How does the feed point impedance of a 1/2 wave dipole antenna change as the antenna is lowered below 1/4 wave above ground?

- A. It steadily increases
- B. It steadily decreases
- C. It peaks at about 1/8 wavelength above ground
- D. It is unaffected by the height above ground

G9B07

(B)

Page 7-6

G9B08
(A)
Page 7-2

G9B08

How does the feed point impedance of a 1/2 wave dipole change as the feed point is moved from the center toward the ends?

- A. It steadily increases
- B. It steadily decreases
- C. It peaks at about 1/8 wavelength from the end
- D. It is unaffected by the location of the feed point

G9B09
(A)
Page 7-7

G9B09

Which of the following is an advantage of a horizontally polarized as compared to a vertically polarized HF antenna?

- A. Lower ground reflection losses
- B. Lower feed point impedance
- C. Shorter Radials
- D. Lower radiation resistance

G9B10
(D)
Page 7-3

G9B10

What is the approximate length for a 1/2 wave dipole antenna cut for 14.250 MHz?

- A. 8 feet
- B. 16 feet
- C. 24 feet
- D. 32 feet

G9B11
(C)
Page 7-3

G9B11

What is the approximate length for a 1/2 wave dipole antenna cut for 3.550 MHz?

- A. 42 feet
- B. 84 feet
- C. 131 feet
- D. 263 feet

G9B12
(A)
Page 7-4

G9B12

What is the approximate length for a 1/4 wave vertical antenna cut for 28.5 MHz?

- A. 8 feet
- B. 11 feet
- C. 16 feet
- D. 21 feet

G9C19
(B)
Page 7-2

G9C19

How does antenna gain stated in dBi compare to gain stated in dBd for the same antenna?

- A. dBi gain figures are 2.15 dB lower than dBd gain figures
- B. dBi gain figures are 2.15 dB higher than dBd gain figures
- C. dBi gain figures are the same as the square root of dBd gain figures multiplied by 2.15
- D. dBi gain figures are the reciprocal of dBd gain figures + 2.15 dB

G9C20
(A)
Page 7-2

G9C20

What is meant by the terms dBi and dBd when referring to antenna gain?

- A. dBi refers to an isotropic antenna, dBd refers to a dipole antenna
- B. dBi refers to an ionospheric reflecting antenna, dBd refers to a dissipative antenna
- C. dBi refers to an inverted-vee antenna, dBd refers to a downward reflecting antenna
- D. dBi refers to an isometric antenna, dBd refers to a discone antenna

Section 7.3

G2D04
(B)
Page 7-7

G2D04

Which of the following describes an azimuthal projection map?

- A. A map that shows accurate land masses
- B. A map that shows true bearings and distances from a particular location
- C. A map that shows the angle at which an amateur satellite crosses the equator
- D. A map that shows the number of degrees longitude that an amateur satellite appears to move westward at the equator with each orbit

G2D11

Which HF antenna would be the best to use for minimizing interference?

- A. A quarter-wave vertical antenna
- B. An isotropic antenna
- C. A directional antenna
- D. An omnidirectional antenna

G2D11
(C)
Page 7-8

G9C01

Which of the following would increase the bandwidth of a Yagi antenna?

- A. Larger diameter elements
- B. Closer element spacing
- C. Loading coils in series with the element
- D. Tapered-diameter elements

G9C01
(A)
Page 7-10

G9C02

What is the approximate length of the driven element of a Yagi antenna?

- A. 1/4 wavelength
- B. 1/2 wavelength
- C. 3/4 wavelength
- D. 1 wavelength

G9C02
(B)
Page 7-9

G9C03

Which statement about a three-element, single-band Yagi antenna is true?

- A. The reflector is normally the shortest element
- B. The director is normally the shortest element
- C. The driven element is the longest element
- D. Low feed point impedance increases bandwidth

G9C03
(B)
Page 7-9

G9C04

Which statement about a three-element, single-band Yagi antenna is true?

- A. The reflector is normally the longest element
- B. The director is normally the longest element
- C. The reflector is normally the shortest element
- D. All of the elements must be the same length

G9C04
(A)
Page 7-9

G9C05
(A)
Page 7-10

G9C05
How does increasing boom length and adding directors affect a Yagi antenna?
A. Gain increases
B. Beamwidth increases
C. Front to back ratio decreases
D. Front to side ratio decreases

G9C07
(C)
Page 7-9

G9C07
What does “front-to-back ratio” mean in reference to a Yagi antenna?
A. The number of directors versus the number of reflectors
B. The relative position of the driven element with respect to the reflectors and directors
C. The power radiated in the major radiation lobe compared to the power radiated in exactly the opposite direction
D. The ratio of forward gain to dipole gain

G9C08
(D)
Page 7-9

G9C08
What is meant by the “main lobe” of a directive antenna?
A. The magnitude of the maximum vertical angle of radiation
B. The point of maximum current in a radiating antenna element
C. The maximum voltage standing wave point on a radiating element
D. The direction of maximum radiated field strength from the antenna

G9C10
(D)
Page 7-10

G9C10
Which of the following is a Yagi antenna design variable that could be adjusted to optimize forward gain, front-to-back ratio, or SWR bandwidth?
A. The physical length of the boom
B. The number of elements on the boom
C. The spacing of each element along the boom
D. All of these choices are correct

G9C11
(A)
Page 7-10

G9C11
What is the purpose of a gamma match used with Yagi antennas?
A. To match the relatively low feed point impedance to 50 ohms
B. To match the relatively high feed point impedance to 50 ohms
C. To increase the front-to-back ratio
D. To increase the main lobe gain

G9C12
(A)
Page 7-11

G9C12
Which of the following is an advantage of using a gamma match for impedance matching of a Yagi antenna to 50 ohm coax feed line?
A. It does not require that the elements be insulated from the boom
B. It does not require any inductors or capacitors
C. It is useful for matching multiband antennas
D. All of these choices are correct

Section 7.4

G9C06

What configuration of the loops of a two-element quad antenna must be used for the antenna to operate as a beam antenna, assuming one of the elements is used as a reflector?

- A. The driven element must be fed with a balun transformer
- B. There must be an open circuit in the driven element at the point opposite the feed point
- C. The reflector element must be approximately 5 percent shorter than the driven element
- D. The reflector element must be approximately 5 percent longer than the driven element

G9C13

Approximately how long is each side of the driven element of a quad antenna?

- A. 1/4 wavelength
- B. 1/2 wavelength
- C. 3/4 wavelength
- D. 1 wavelength

G9C14

How does the forward gain of a two-element quad antenna compare to the forward gain of a three-element Yagi antenna?

- A. About 2/3 as much
- B. About the same
- C. About 1.5 times as much
- D. About twice as much

G9C15

Approximately how long is each side of the reflector element of a quad antenna?

- A. Slightly less than 1/4 wavelength
- B. Slightly more than 1/4 wavelength
- C. Slightly less than 1/2 wavelength
- D. Slightly more than 1/2 wavelength

G9C16

How does the gain of a two-element delta-loop beam compare to the gain of a two-element quad antenna?

- A. 3 dB higher
- B. 3 dB lower
- C. 2.54 dB higher
- D. About the same

G9C17

Approximately how long is each leg of a symmetrical delta-loop antenna?

- A. 1/4 wavelength
- B. 1/3 wavelength
- C. 1/2 wavelength
- D. 2/3 wavelength

G9C06

(D)

Page 7-12

G9C13

(A)

Page 7-12

G9C14

(B)

Page 7-12

G9C15

(B)

Page 7-12

G9C16

(D)

Page 7-12

G9C17

(B)

Page 7-12

G9C18
(A)
Page 7-13

- G9C18**
- What happens when the feed point of a quad antenna of any shape is moved from the midpoint of the top or bottom to the midpoint of either side?
- A. The polarization of the radiated signal changes from horizontal to vertical
 - B. The polarization of the radiated signal changes from vertical to horizontal
 - C. There is no change in polarization
 - D. The radiated signal becomes circularly polarized

Section 7.5

G9C09
(B)
Page 7-14

- G9C09**
- How does the gain of two 3-element horizontally polarized Yagi antennas spaced vertically 1/2 wavelength apart typically compare to the gain of a single 3-element Yagi?
- A. Approximately 1.5 dB higher
 - B. Approximately 3 dB higher
 - C. Approximately 6 dB higher
 - D. Approximately 9 dB higher

G9D01
(D)
Page 7-13

- G9D01**
- What does the term NVIS mean as related to antennas?
- A. Nearly Vertical Inductance System
 - B. Non-Varying Indicated SWR
 - C. Non-Varying Impedance Smoothing
 - D. Near Vertical Incidence sky-wave

G9D02
(B)
Page 7-13

- G9D02**
- Which of the following is an advantage of an NVIS antenna?
- A. Low vertical angle radiation for working stations out to ranges of several thousand kilometers
 - B. High vertical angle radiation for working stations within a radius of a few hundred kilometers
 - C. High forward gain
 - D. All of these choices are correct

G9D03
(D)
Page 7-14

- G9D03**
- At what height above ground is an NVIS antenna typically installed?
- A. As close to 1/2 wavelength as possible
 - B. As close to one wavelength as possible
 - C. Height is not critical as long as it is significantly more than 1/2 wavelength
 - D. Between 1/10 and 1/4 wavelength

G9D04
(A)
Page 7-16

- G9D04**
- What is the primary purpose of antenna traps?
- A. To permit multiband operation
 - B. To notch spurious frequencies
 - C. To provide balanced feed point impedance
 - D. To prevent out of band operation

G9D05

What is an advantage of vertical stacking of horizontally polarized Yagi antennas?

- A. It allows quick selection of vertical or horizontal polarization
- B. It allows simultaneous vertical and horizontal polarization
- C. It narrows the main lobe in azimuth
- D. It narrows the main lobe in elevation

G9D05

(D)

Page 7-14

G9D06

Which of the following is an advantage of a log periodic antenna?

- A. Wide bandwidth
- B. Higher gain per element than a Yagi antenna
- C. Harmonic suppression
- D. Polarization diversity

G9D06

(A)

Page 7-14

G9D07

Which of the following describes a log periodic antenna?

- A. Length and spacing of the elements increase logarithmically from one end of the boom to the other
- B. Impedance varies periodically as a function of frequency
- C. Gain varies logarithmically as a function of frequency
- D. SWR varies periodically as a function of boom length

G9D07

(A)

Page 7-14

G9D08

Why is a Beverage antenna not used for transmitting?

- A. Its impedance is too low for effective matching
- B. It has high losses compared to other types of antennas
- C. It has poor directivity
- D. All of these choices are correct

G9D08

(B)

Page 7-15

G9D09

Which of the following is an application for a Beverage antenna?

- A. Directional transmitting for low HF bands
- B. Directional receiving for low HF bands
- C. Portable direction finding at higher HF frequencies
- D. Portable direction finding at lower HF frequencies

G9D09

(B)

Page 7-15

G9D10

Which of the following describes a Beverage antenna?

- A. A vertical antenna
- B. A broad-band mobile antenna
- C. A helical antenna for space reception
- D. A very long and low directional receiving antenna

G9D10

(D)

Page 7-15

G9D11

Which of the following is a disadvantage of multiband antennas?

- A. They present low impedance on all design frequencies
- B. They must be used with an antenna tuner
- C. They must be fed with open wire line
- D. They have poor harmonic rejection

G9D11

(D)

Page 7-16

Section 7.6

G4A06
(C)
Page 7-19

G4A06

What type of device is often used to match transmitter output impedance to an impedance not equal to 50 ohms?

- A. Balanced modulator
- B. SWR Bridge
- C. Antenna coupler or antenna tuner
- D. Q Multiplier

G9A01
(A)
Page 7-17

G9A01

Which of the following factors determine the characteristic impedance of a parallel conductor antenna feed line?

- A. The distance between the centers of the conductors and the radius of the conductors
- B. The distance between the centers of the conductors and the length of the line
- C. The radius of the conductors and the frequency of the signal
- D. The frequency of the signal and the length of the line

G9A02
(B)
Page 7-18

G9A02

What are the typical characteristic impedances of coaxial cables used for antenna feed lines at amateur stations?

- A. 25 and 30 ohms
- B. 50 and 75 ohms
- C. 80 and 100 ohms
- D. 500 and 750 ohms

G9A03
(D)
Page 7-18

G9A03

What is the characteristic impedance of flat ribbon TV type twinlead?

- A. 50 ohms
- B. 75 ohms
- C. 100 ohms
- D. 300 ohms

G9A04
(C)
Page 7-18

G9A04

What might cause reflected power at the point where a feed line connects to an antenna?

- A. Operating an antenna at its resonant frequency
- B. Using more transmitter power than the antenna can handle
- C. A difference between feed line impedance and antenna feed point impedance
- D. Feeding the antenna with unbalanced feed line

G9A05
(B)
Page 7-20

G9A05

How does the attenuation of coaxial cable change as the frequency of the signal it is carrying increases?

- A. Attenuation is independent of frequency
- B. Attenuation increases
- C. Attenuation decreases
- D. Attenuation reaches a maximum at approximately 18 MHz

G9A06

In what units is RF feed line loss usually expressed?

- A. Ohms per 1000 feet
- B. Decibels per 1000 feet
- C. Ohms per 100 feet
- D. Decibels per 100 feet

G9A06

(D)

Page 7-20

G9A07

What must be done to prevent standing waves on an antenna feed line?

- A. The antenna feed point must be at DC ground potential
- B. The feed line must be cut to a length equal to an odd number of electrical quarter wavelengths
- C. The feed line must be cut to a length equal to an even number of physical half wavelengths
- D. The antenna feed point impedance must be matched to the characteristic impedance of the feed line

G9A07

(D)

Page 7-19

G9A08

If the SWR on an antenna feed line is 5 to 1, and a matching network at the transmitter end of the feed line is adjusted to 1 to 1 SWR, what is the resulting SWR on the feed line?

- A. 1 to 1
- B. 5 to 1
- C. Between 1 to 1 and 5 to 1 depending on the characteristic impedance of the line
- D. Between 1 to 1 and 5 to 1 depending on the reflected power at the transmitter

G9A08

(B)

Page 7-19

G9A09

What standing wave ratio will result when connecting a 50 ohm feed line to a non-reactive load having 200 ohm impedance?

- A. 4:1
- B. 1:4
- C. 2:1
- D. 1:2

G9A09

(A)

Page 7-18

G9A10

What standing wave ratio will result when connecting a 50 ohm feed line to a non-reactive load having 10 ohm impedance?

- A. 2:1
- B. 50:1
- C. 1:5
- D. 5:1

G9A10

(D)

Page 7-18

G9A11

What standing wave ratio will result when connecting a 50 ohm feed line to a non-reactive load having 50 ohm impedance?

- A. 2:1
- B. 1:1
- C. 50:50
- D. 0:0

G9A11

(B)

Page 7-18

G9A12
(A)
Page 7-18

G9A12

What standing wave ratio will result when connecting a 50 ohm feed line to a non-reactive load having 25 ohm impedance?

- A. 2:1
- B. 2.5:1
- C. 1.25:1
- D. You cannot determine SWR from impedance values

G9A13
(C)
Page 7-18

G9A13

What standing wave ratio will result when connecting a 50 ohm feed line to an antenna that has a purely resistive 300 ohm feed point impedance?

- A. 1.5:1
- B. 3:1
- C. 6:1
- D. You cannot determine SWR from impedance values

G9A14
(B)
Page 7-20

G9A14

What is the interaction between high standing wave ratio (SWR) and transmission line loss?

- A. There is no interaction between transmission line loss and SWR
- B. If a transmission line is lossy, high SWR will increase the loss
- C. High SWR makes it difficult to measure transmission line loss
- D. High SWR reduces the relative effect of transmission line loss

G9A15
(A)
Page 7-20

G9A15

What is the effect of transmission line loss on SWR measured at the input to the line?

- A. The higher the transmission line loss, the more the SWR will read artificially low
- B. The higher the transmission line loss, the more the SWR will read artificially high
- C. The higher the transmission line loss, the more accurate the SWR measurement will be
- D. Transmission line loss does not affect the SWR measurement

Chapter 8

Section 8.1

G2D06

How is a directional antenna pointed when making a “long-path” contact with another station?

- A. Toward the rising Sun
- B. Along the gray line
- C. 180 degrees from its short-path heading
- D. Toward the north

G2D06
(C)
Page 8-5

G3B01

How might a sky-wave signal sound if it arrives at your receiver by both short path and long path propagation?

- A. Periodic fading approximately every 10 seconds
- B. Signal strength increased by 3 dB
- C. The signal might be cancelled causing severe attenuation
- D. A well-defined echo might be heard

G3B01
(D)
Page 8-5

G3B02

Which of the following is a good indicator of the possibility of sky-wave propagation on the 6-meter band?

- A. Short skip sky-wave propagation on the 10-meter band
- B. Long skip sky-wave propagation on the 10-meter band
- C. Severe attenuation of signals on the 10-meter band
- D. Long delayed echoes on the 10-meter band

G3B02
(A)
Page 8-4

G3B05

What usually happens to radio waves with frequencies below the MUF and above the LUF when they are sent into the ionosphere?

- A. They are bent back to the Earth
- B. They pass through the ionosphere
- C. They are amplified by interaction with the ionosphere
- D. They are bent and trapped in the ionosphere to circle the Earth

G3B05
(A)
Page 8-3

G3B09

What is the approximate maximum distance along the Earth’s surface that is normally covered in one hop using the F2 region?

- A. 180 miles
- B. 1,200 miles
- C. 2,500 miles
- D. 12,000 miles

G3B09
(C)
Page 8-4

G3B10

What is the approximate maximum distance along the Earth’s surface that is normally covered in one hop using the E region?

- A. 180 miles
- B. 1,200 miles
- C. 2,500 miles
- D. 12,000 miles

G3B10
(B)
Page 8-4

<p>G3C01 (A) Page 8-1</p>	<p>G3C01</p> <p>Which ionospheric layer is closest to the surface of the Earth?</p> <ul style="list-style-type: none"> A. The D layer B. The E layer C. The F1 layer D. The F2 layer
<p>G3C02 (A) Page 8-3</p>	<p>G3C02</p> <p>Where on the Earth do ionospheric layers reach their maximum height?</p> <ul style="list-style-type: none"> A. Where the Sun is overhead B. Where the Sun is on the opposite side of the Earth C. Where the Sun is rising D. Where the Sun has just set
<p>G3C03 (C) Page 8-4</p>	<p>G3C03</p> <p>Why is the F2 region mainly responsible for the longest distance radio wave propagation?</p> <ul style="list-style-type: none"> A. Because it is the densest ionospheric layer B. Because it does not absorb radio waves as much as other ionospheric regions C. Because it is the highest ionospheric region D. All of these choices are correct
<p>G3C04 (D) Page 8-3</p>	<p>G3C04</p> <p>What does the term “critical angle” mean as used in radio wave propagation?</p> <ul style="list-style-type: none"> A. The long path azimuth of a distant station B. The short path azimuth of a distant station C. The lowest takeoff angle that will return a radio wave to the Earth under specific ionospheric conditions D. The highest takeoff angle that will return a radio wave to the Earth under specific ionospheric conditions
<p>G3C05 (C) Page 8-4</p>	<p>G3C05</p> <p>Why is long distance communication on the 40-meter, 60-meter, 80-meter and 160-meter bands more difficult during the day?</p> <ul style="list-style-type: none"> A. The F layer absorbs signals at these frequencies during daylight hours B. The F layer is unstable during daylight hours C. The D layer absorbs signals at these frequencies during daylight hours D. The E layer is unstable during daylight hours
<p>G3C12 (D) Page 8-4</p>	<p>G3C12</p> <p>Which ionospheric layer is the most absorbent of long skip signals during daylight hours on frequencies below 10 MHz?</p> <ul style="list-style-type: none"> A. The F2 layer B. The F1 layer C. The E layer D. The D layer

Section 8.2

G3A01

What is the significance of the sunspot number with regard to HF propagation?

- A. Higher sunspot numbers generally indicate a greater probability of good propagation at higher frequencies
- B. Lower sunspot numbers generally indicate greater probability of sporadic E propagation
- C. A zero sunspot number indicate radio propagation is not possible on any band
- D. All of these choices are correct.

G3A01
(A)
Page 8-5

G3A02

What effect does a Sudden Ionospheric Disturbance have on the daytime ionospheric propagation of HF radio waves?

- A. It enhances propagation on all HF frequencies
- B. It disrupts signals on lower frequencies more than those on higher frequencies
- C. It disrupts communications via satellite more than direct communications
- D. None, because only areas on the night side of the Earth are affected

G3A02
(B)
Page 8-9

G3A03

Approximately how long does it take the increased ultraviolet and X-ray radiation from solar flares to affect radio propagation on the Earth?

- A. 28 days
- B. 1 to 2 hours
- C. 8 minutes
- D. 20 to 40 hours

G3A03
(C)
Page 8-8

G3A04

Which of the following are least reliable for long distance communications during periods of low solar activity?

- A. 80 meters and 160 meters
- B. 60 meters and 40 meters
- C. 30 meters and 20 meters
- D. 15 meters, 12 meters and 10 meters

G3A04
(D)
Page 8-6

G3A05

What is the solar flux index?

- A. A measure of the highest frequency that is useful for ionospheric propagation between two points on the Earth
- B. A count of sunspots which is adjusted for solar emissions
- C. Another name for the American sunspot number
- D. A measure of solar radiation at 10.7 centimeters wavelength

G3A05
(D)
Page 8-7

G3A06

What is a geomagnetic storm?

- A. A sudden drop in the solar flux index
- B. A thunderstorm which affects radio propagation
- C. Ripples in the ionosphere
- D. A temporary disturbance in the Earth's magnetosphere

G3A06
(D)
Page 8-9

<p>G3A07 (D) Page 8-6</p>	<p>G3A07</p>	<p>At what point in the solar cycle does the 20-meter band usually support worldwide propagation during daylight hours?</p> <p>A. At the summer solstice B. Only at the maximum point of the solar cycle C. Only at the minimum point of the solar cycle D. At any point in the solar cycle</p>
<p>G3A08 (B) Page 8-9</p>	<p>G3A08</p>	<p>Which of the following effects can a geomagnetic storm have on radio propagation?</p> <p>A. Improved high-latitude HF propagation B. Degraded high-latitude HF propagation C. Improved ground-wave propagation D. Improved chances of UHF ducting</p>
<p>G3A09 (C) Page 8-6</p>	<p>G3A09</p>	<p>What effect does a high sunspot number have on radio communications?</p> <p>A. High-frequency radio signals become weak and distorted B. Frequencies above 300 MHz become usable for long-distance communication C. Long-distance communication in the upper HF and lower VHF range is enhanced D. Microwave communications become unstable</p>
<p>G3A10 (C) Page 8-6</p>	<p>G3A10</p>	<p>What causes HF propagation conditions to vary periodically in a 28 day cycle?</p> <p>A. Long term oscillations in the upper atmosphere B. Cyclic variation in the Earth's radiation belts C. The Sun's rotation on its axis D. The position of the Moon in its orbit</p>
<p>G3A11 (D) Page 8-5</p>	<p>G3A11</p>	<p>Approximately how long is the typical sunspot cycle?</p> <p>A. 8 minutes B. 40 hours C. 28 days D. 11 years</p>
<p>G3A12 (B) Page 8-7</p>	<p>G3A12</p>	<p>What does the K-index indicate?</p> <p>A. The relative position of sunspots on the surface of the Sun B. The short term stability of the Earth's magnetic field C. The stability of the Sun's magnetic field D. The solar radio flux at Boulder, Colorado</p>
<p>G3A13 (C) Page 8-7</p>	<p>G3A13</p>	<p>What does the A-index indicate?</p> <p>A. The relative position of sunspots on the surface of the Sun B. The amount of polarization of the Sun's electric field C. The long term stability of the Earth's geomagnetic field D. The solar radio flux at Boulder, Colorado</p>

G3A14

How are radio communications usually affected by the charged particles that reach the Earth from solar coronal holes?

- A. HF communications are improved
- B. HF communications are disturbed
- C. VHF/UHF ducting is improved
- D. VHF/UHF ducting is disturbed

G3A14

(B)

Page 8-9

G3A15

How long does it take charged particles from coronal mass ejections to affect radio propagation on the Earth?

- A. 28 days
- B. 14 days
- C. 4 to 8 minutes
- D. 20 to 40 hours

G3A15

(D)

Page 8-9

G3A16

What is a possible benefit to radio communications resulting from periods of high geomagnetic activity?

- A. Auroras that can reflect VHF signals
- B. Higher signal strength for HF signals passing through the polar regions
- C. Improved HF long path propagation
- D. Reduced long delayed echoes

G3A16

(A)

Page 8-10

G3B03

Which of the following applies when selecting a frequency for lowest attenuation when transmitting on HF?

- A. Select a frequency just below the MUF
- B. Select a frequency just above the LUF
- C. Select a frequency just below the critical frequency
- D. Select a frequency just above the critical frequency

G3B03

(A)

Page 8-8

G3B04

What is a reliable way to determine if the MUF is high enough to support skip propagation between your station and a distant location on frequencies between 14 and 30 MHz?

- A. Listen for signals from an international beacon in the frequency range you plan to use
- B. Send a series of dots on the band and listen for echoes from your signal
- C. Check the strength of TV signals from Western Europe
- D. Check the strength of signals in the MF AM broadcast band

G3B04

(A)

Page 8-8

G3B06

What usually happens to radio waves with frequencies below the LUF?

- A. They are bent back to the Earth
- B. They pass through the ionosphere
- C. They are completely absorbed by the ionosphere
- D. They are bent and trapped in the ionosphere to circle the Earth

G3B06

(C)

Page 8-8

G3B07
(A)
Page 8-7

G3B07
What does LUF stand for?
A. The Lowest Usable Frequency for communications between two points
B. The Longest Universal Function for communications between two points
C. The Lowest Usable Frequency during a 24 hour period
D. The Longest Universal Function during a 24 hour period

G3B08
(B)
Page 8-7

G3B08
What does MUF stand for?
A. The Minimum Usable Frequency for communications between two points
B. The Maximum Usable Frequency for communications between two points
C. The Minimum Usable Frequency during a 24 hour period
D. The Maximum Usable Frequency during a 24 hour period

G3B11
(A)
Page 8-8

G3B11
What happens to HF propagation when the LUF exceeds the MUF?
A. No HF radio frequency will support ordinary sky-wave communications over the path
B. HF communications over the path are enhanced
C. Double hop propagation along the path is more common
D. Propagation over the path on all HF frequencies is enhanced

G3B12
(D)
Page 8-7

G3B12
What factor or factors affect the MUF?
A. Path distance and location
B. Time of day and season
C. Solar radiation and ionospheric disturbances
D. All of these choices are correct

Section 8.3

G3C06
(B)
Page 8-11

G3C06
What is a characteristic of HF scatter signals?
A. They have high intelligibility
B. They have a wavering sound
C. They have very large swings in signal strength
D. All of these choices are correct

G3C07
(D)
Page 8-11

G3C07
What makes HF scatter signals often sound distorted?
A. The ionospheric layer involved is unstable
B. Ground waves are absorbing much of the signal
C. The E-region is not present
D. Energy is scattered into the skip zone through several different radio wave paths

G3C08

Why are HF scatter signals in the skip zone usually weak?

- A. Only a small part of the signal energy is scattered into the skip zone
- B. Signals are scattered from the magnetosphere which is not a good reflector
- C. Propagation is through ground waves which absorb most of the signal energy
- D. Propagations is through ducts in F region which absorb most of the energy

G3C08
(A)
Page 8-11

G3C09

What type of radio wave propagation allows a signal to be detected at a distance too far for ground wave propagation but too near for normal sky-wave propagation?

- A. Faraday rotation
- B. Scatter
- C. Sporadic-E skip
- D. Short-path skip

G3C09
(B)
Page 8-11

G3C10

Which of the following might be an indication that signals heard on the HF bands are being received via scatter propagation?

- A. The communication is during a sunspot maximum
- B. The communication is during a sudden ionospheric disturbance
- C. The signal is heard on a frequency below the Maximum Usable Frequency
- D. The signal is heard on a frequency above the Maximum Usable Frequency

G3C10
(D)
Page 8-11

G3C11

Which of the following antenna types will be most effective for skip communications on 40-meters during the day?

- A. A vertical antenna
- B. A horizontal dipole placed between $1/8$ and $1/4$ wavelength above the ground
- C. A left-hand circularly polarized antenna
- D. A right-hand circularly polarized antenna

G3C11
(B)
Page 8-11

G3C13

What is Near Vertical Incidence Sky-wave (NVIS) propagation?

- A. Propagation near the MUF
- B. Short distance MF or HF propagation using high elevation angles
- C. Long path HF propagation at sunrise and sunset
- D. Double hop propagation near the LUF

G3C13
(B)
Page 8-11

Chapter 9

Section 9.1

G0B01
(A)
Page 9-5

G0B01

Which wire or wires in a four-conductor connection should be attached to fuses or circuit breakers in a device operated from a 240 VAC single phase source?

- A. Only the two wires carrying voltage
- B. Only the neutral wire
- C. Only the ground wire
- D. All wires

G0B02
(C)
Page 9-4

G0B02

What is the minimum wire size that may be safely used for a circuit that draws up to 20 amperes of continuous current?

- A. AWG number 20
- B. AWG number 16
- C. AWG number 12
- D. AWG number 8

G0B03
(D)
Page 9-4

G0B03

Which size of fuse or circuit breaker would be appropriate to use with a circuit that uses AWG number 14 wiring?

- A. 100 amperes
- B. 60 amperes
- C. 30 amperes
- D. 15 amperes

G0B04
(A)
Page 9-6

G0B04

Which of the following is a primary reason for not placing a gasoline-fueled generator inside an occupied area?

- A. Danger of carbon monoxide poisoning
- B. Danger of engine over torque
- C. Lack of oxygen for adequate combustion
- D. Lack of nitrogen for adequate combustion

G0B05
(B)
Page 9-5

G0B05

Which of the following conditions will cause a Ground Fault Circuit Interrupter (GFCI) to disconnect the 120 or 240 Volt AC line power to a device?

- A. Current flowing from one or more of the voltage-carrying wires to the neutral wire
- B. Current flowing from one or more of the voltage-carrying wires directly to ground
- C. Overvoltage on the voltage-carrying wires
- D. All of these choices are correct

G0B06

Why must the metal enclosure of every item of station equipment be grounded?

- A. It prevents a blown fuse in the event of an internal short circuit
- B. It prevents signal overload
- C. It ensures that the neutral wire is grounded
- D. It ensures that hazardous voltages cannot appear on the chassis

G0B06
(D)
Page 9-4

G0B09

Why should soldered joints not be used with the wires that connect the base of a tower to a system of ground rods?

- A. The resistance of solder is too high
- B. Solder flux will prevent a low conductivity connection
- C. Solder has too high a dielectric constant to provide adequate lightning protection
- D. A soldered joint will likely be destroyed by the heat of a lightning strike

G0B09
(D)
Page 9-7

G0B10

Which of the following is a danger from lead-tin solder?

- A. Lead can contaminate food if hands are not washed carefully after handling the solder
- B. High voltages can cause lead-tin solder to disintegrate suddenly
- C. Tin in the solder can “cold flow” causing shorts in the circuit
- D. RF energy can convert the lead into a poisonous gas

G0B10
(A)
Page 9-2

G0B11

Which of the following is good practice for lightning protection grounds?

- A. They must be bonded to all buried water and gas lines
- B. Bends in ground wires must be made as close as possible to a right angle
- C. Lightning grounds must be connected to all ungrounded wiring
- D. They must be bonded together with all other grounds

G0B11
(D)
Page 9-7

G0B12

What is the purpose of a power supply interlock?

- A. To prevent unauthorized changes to the circuit that would void the manufacturer’s warranty
- B. To shut down the unit if it becomes too hot
- C. To ensure that dangerous voltages are removed if the cabinet is opened
- D. To shut off the power supply if too much voltage is produced

G0B12
(C)
Page 9-5

G0B13

What must you do when powering your house from an emergency generator?

- A. Disconnect the incoming utility power feed
- B. Insure that the generator is not grounded
- C. Insure that all lightning grounds are disconnected
- D. All of these choices are correct

G0B13
(A)
Page 9-6

G0B14

Which of the following is covered by the National Electrical Code?

- A. Acceptable bandwidth limits
- B. Acceptable modulation limits
- C. Electrical safety inside the ham shack
- D. RF exposure limits of the human body

G0B14
(C)
Page 9-3

G0B15
(A)
Page 9-6

G0B15

Which of the following is true of an emergency generator installation?

- A. The generator should be located in a well-ventilated area
- B. The generator must be insulated from ground
- C. Fuel should be stored near the generator for rapid refueling in case of an emergency
- D. All of these choices are correct

Section 9.2

G0A01
(A)
Page 9-8

G0A01

What is one way that RF energy can affect human body tissue?

- A. It heats body tissue
- B. It causes radiation poisoning
- C. It causes the blood count to reach a dangerously low level
- D. It cools body tissue

G0A02
(D)
Page 9-7

G0A02

Which of the following properties is important in estimating whether an RF signal exceeds the maximum permissible exposure (MPE)?

- A. Its duty cycle
- B. Its frequency
- C. Its power density
- D. All of these choices are correct

G0A03
(D)
[97.13(c)(1)]
Page 9-10

G0A03

How can you determine that your station complies with FCC RF exposure regulations?

- A. By calculation based on FCC OET Bulletin 65
- B. By calculation based on computer modeling
- C. By measurement of field strength using calibrated equipment
- D. All of these choices are correct

G0A04
(D)
Page 9-9

G0A04

What does “time averaging” mean in reference to RF radiation exposure?

- A. The average amount of power developed by the transmitter over a specific 24 hour period
- B. The average time it takes RF radiation to have any long-term effect on the body
- C. The total time of the exposure
- D. The total RF exposure averaged over a certain time

G0A05
(A)
Page 9-11

G0A05

What must you do if an evaluation of your station shows RF energy radiated from your station exceeds permissible limits?

- A. Take action to prevent human exposure to the excessive RF fields
- B. File an Environmental Impact Statement (EIS-97) with the FCC
- C. Secure written permission from your neighbors to operate above the controlled MPE limits
- D. All of these choices are correct

G0A06

What precaution should be taken when installing a ground-mounted antenna?

- A. It should not be installed higher than you can reach
- B. It should not be installed in a wet area
- C. It should be limited to 10 feet in height
- D. It should be installed such that it is protected against unauthorized access

G0A06

(D)

Page 9-11

G0A07

What effect does transmitter duty cycle have when evaluating RF exposure?

- A. A lower transmitter duty cycle permits greater short-term exposure levels
- B. A higher transmitter duty cycle permits greater short-term exposure levels
- C. Low duty cycle transmitters are exempt from RF exposure evaluation requirements
- D. High duty cycle transmitters are exempt from RF exposure requirements

G0A07

(A)

Page 9-9

G0A08

Which of the following steps must an amateur operator take to ensure compliance with RF safety regulations when transmitter power exceeds levels specified in FCC Part 97.13?

- A. Post a copy of FCC Part 97.13 in the station
- B. Post a copy of OET Bulletin 65 in the station
- C. Perform a routine RF exposure evaluation
- D. All of these choices are correct

G0A08

(C)

Page 9-10

G0A09

What type of instrument can be used to accurately measure an RF field?

- A. A receiver with an S meter
- B. A calibrated field strength meter with a calibrated antenna
- C. An SWR meter with a peak-reading function
- D. An oscilloscope with a high-stability crystal marker generator

G0A09

(B)

Page 9-10

G0A10

What is one thing that can be done if evaluation shows that a neighbor might receive more than the allowable limit of RF exposure from the main lobe of a directional antenna?

- A. Change to a non-polarized antenna with higher gain
- B. Post a warning sign that is clearly visible to the neighbor
- C. Use an antenna with a higher front-to-back ratio
- D. Take precautions to ensure that the antenna cannot be pointed in their direction

G0A10

(D)

Page 9-11

G0A11

What precaution should you take if you install an indoor transmitting antenna?

- A. Locate the antenna close to your operating position to minimize feed line radiation
- B. Position the antenna along the edge of a wall to reduce parasitic radiation
- C. Make sure that MPE limits are not exceeded in occupied areas
- D. Make sure the antenna is properly shielded

G0A11

(C)

Page 9-12

Section 9.3

G0A12
(B)
Page 9-13

G0A12

What precaution should you take whenever you make adjustments or repairs to an antenna?

- A. Ensure that you and the antenna structure are grounded
- B. Turn off the transmitter and disconnect the feed line
- C. Wear a radiation badge
- D. All of these choices are correct

G0B07
(B)
Page 9-14

G0B07

Which of these choices should be observed when climbing a tower using a safety belt or harness?

- A. Never lean back and rely on the belt alone to support your weight
- B. Confirm that the belt is rated for the weight of the climber and that it is within its allowable service life
- C. Ensure that all heavy tools are securely fastened to the belt D-ring
- D. All of these choices are correct

G0B08
(B)
Page 9-13

G0B08

What should be done by any person preparing to climb a tower that supports electrically powered devices?

- A. Notify the electric company that a person will be working on the tower
- B. Make sure all circuits that supply power to the tower are locked out and tagged
- C. Unground the base of the tower
- D. All of these choices are correct