

# Test Procedures Manual

by Bob Allison, WB1GCM, ARRL Test Engineer  
Michael Tracy, KC1SX, ARRL Technical Advisor  
Mike Gruber, W1MG, ARRL EMC/RFI Engineer

## **Revision history:**

Initial document: September 1990  
Revision A, October 1992, updates and corrections  
Revision B, January 1996, major revision, additional tests added  
Revision C, April 1997, updates and corrections  
Revision D, November 1997, new graphics, updates and corrections  
Revision E, August 1998, expanded test information added  
Revision F, June 2000, BER test box changes added  
Revision G, January 2002, new schematics added to Appendix A  
Revision H, June 2004, updates for new test equipment added  
Revision I, January 2009, major revision, additional tests added  
Revision J, June 2009, updates and corrections



## TABLE OF CONTENTS

I. PURPOSE AND SCOPE.....	4
II. LIST OF FIGURES.....	5
III. LIST OF REQUIRED TEST INSTRUMENTS.....	6
IV. TRANSMITTER TESTS.....	7
4.1 OUTPUT POWER TEST.....	8
4.2 TRANSMIT FREQUENCY RANGE TEST.....	10
4.3 CW TRANSMIT-FREQUENCY ACCURACY TEST.....	12
4.4 SPECTRAL PURITY TEST.....	14
4.5 TWO-TONE TRANSMIT IMD TEST.....	17
4.6 SSB CARRIER AND UNWANTED SIDEBAND SUPPRESSION AT 14.250 MHz.....	19
4.7 CW KEYING WAVEFORM TEST.....	21
4.8 PTT TO SSB/FM RF OUTPUT TEST.....	24
4.9 TRANSMIT/RECEIVE TURN-AROUND TEST.....	26
4.10 KEYSER SPEED AND SIDETONE FREQUENCY TEST.....	29
4.11 COMPOSITE NOISE TEST.....	31
V. RECEIVER TESTS.....	34
5.1 NOISE FLOOR TEST.....	35
5.2 AM RECEIVE SENSITIVITY TEST.....	37
5.3 FM SINAD AND QUIETING TEST.....	39
5.4 RECEIVE FREQUENCY RANGE TEST.....	42
5.5 FIRST IF AND IMAGE REJECTION TEST.....	44
5.6 ANTENNA PORT ISOLATION TEST.....	47
5.7 BLOCKING GAIN COMPRESSION.....	49
5.7A RECIPROCAL MIXING.....	52
5.8 TWO-TONE 2ND AND 3RD ORDER DYNAMIC RANGE TEST.....	54
5.9 FM ADJACENT-CHANNEL SELECTIVITY TEST.....	59
5.10 FM TWO-TONE 3RD ORDER DYNAMIC RANGE TEST.....	63
5.11 AUDIO POWER OUTPUT TEST.....	66
5.12 AUDIO AND IF FREQUENCY RESPONSE TEST.....	68
5.13 SQUELCH SENSITIVITY TEST.....	71
5.14 S METER TEST.....	73
5.15 IN BAND IMD TEST.....	75
5.16 NOTCH FILTER TEST.....	78
5.17 EQUIVALENT RECTANGULAR BANDWIDTH TEST.....	83
5.18 NOISE FIGURE CALCULATION.....	83
VI. NON-STANDARD AND SPECIAL PURPOSE TESTS.....	84
6.1 LOW VOLTAGE AND TEMPERATURE CHAMBER TEST.....	84
6.2 DSP NOISE REDUCTION TEST.....	86
6.3 RECEIVER BIT-ERROR RATE TEST.....	89
6.4 TRANSMITTER BIT-ERROR RATE TEST.....	92
6.6 POWER METER TEST.....	94
DATA SHEETS.....	100
6.7 HF LINEAR AMPLIFIER TEST.....	126
6.7B LINEAR AMPLIFIER IMD TEST.....	128
LINEAR AMPLIFIER DATA SHEET.....	131
ABOUT THE LINEAR AMPLIFIER IMD TEST FIXTURE.....	132
VII. APPENDIX A: ARRL CUSTOM TEST CIRCUITS.....	133
VIII. APPENDIX B: FORMULAS FOR QST PRODUCT REVIEW CALCULATIONS.....	158

## **PURPOSE AND SCOPE**

### **1.1 PURPOSE**

The purpose of this manual is to ensure that all ARRL testing of HF transceivers, transmitters, and receivers will be conducted in a consistent and well-defined manner. The procedures used for this testing have been broken down into clear, step-by-step instructions. All testing should be "done by the book" in order to guarantee that all equipment is evaluated to the same standards.

This manual contains three major sections: Transmitter tests (Chapter 4), Receiver tests (Chapter 5) and Data Sheets (Chapter 6). The data sheets are arranged to allow test results to be recorded in the same order that measurements are taken.

### **1.2 SCOPE**

This manual is designed to cover a wide range of amateur HF equipment. It is not intended to replace common sense or the expertise of an experienced test engineer. It is important, therefore, for the test engineer to be familiar with the Lab test equipment and the Device Under Test (DUT). The manufacturer's manual for the DUT should be completely read and understood before any testing is performed. At no time should any equipment be operated in a manner that is inconsistent with the manufacturer's recommended procedures or published limits. Failure to understand the unit under test could result in test error or, even worse, damage to the equipment, or worst of all, damage to the test engineer.

## II. LIST OF FIGURES

Figure	Description
4-1	Power Output Test Hook-Up
4-2	Transmit Frequency Range Test Hook-Up (no changes from 4-1)
4-3	CW Transmit Accuracy Test Hook-Up
4-4	Spectral Purity Test Hook-Up
4-4A	Example Spectral Purity Plot
4-5	Two-Tone Transmit IMD Test Hook-Up
4-6	SSB Carrier and Unwanted Sideband Suppression Test Hook-Up (no changes from 4-5)
4-7	CW Keying Waveform Test Hook-Up
4-7A	Example Scope Trace of RF Output CW Keying Waveform
4-8	PTT SSB/FM RF Output Test Hook-Up
4-9	Transmit/Receive Turn-Around Time Test Hook-Up
4-10	Keyer Speed and Sidetone Frequency Test Hook-Up
4-11	Composite Noise Test Hook-Up
5-1	CW Minimum Discernible Signal (MDS) Test Hook-Up
5-2	AM Receive Sensitivity Test Hook-Up
5-3	FM SINAD and Quieting Test Hook-Up
5-4	Receive Frequency Range Test Hook-Up
5-5	First IF and Image Rejection Test Hook-Up
5-6	Antenna Port Isolation Test Hook-Up
5-7	Blocking Gain Compression Test Hook-Up
5-7A	Reciprocal Mixing Test Hook-Up
5-8	Two-Tone, 3rd Order Dynamic Range Test Hook-Up
5-9	FM Adjacent Channel Selectivity Test Hook-Up
5-10	FM Two-Tone, 3rd Order Dynamic Range Test Hook-Up
5-11	Audio Power Output Test Hook-Up
5-12	Audio and IF Frequency Response Test Hook-Up
5-13	Squelch Sensitivity Test Hook-Up
5-14	S-Meter Test Hook-Up
5-15	In-Band IMD Test Hook-Up
5-16	Notch Filter Test Hook-Up
5-17	Equivalent Rectangular Bandwidth Test Hook-Up
6-1	Low Voltage and Temperature Chamber Test Hook-Up
6-2	DSP Noise Reduction Test Hook-Up
6-3	Receiver Bit-Error-Rate (BER) Test Hook-Up
6-4	Transmitter Bit-Error-Rate (BER) Test Hook-Up
6-5	Receiver Phase-Noise Test Hook-Up

## II. LIST OF REQUIRED TEST INSTRUMENTS

Instrument (or equivalent)	Manufacturer	Model	Qty.
Spectrum Analyzer	HP	HP8563E	1
Distortion/Audio Meter	HP	339A	1
RF Signal Generator	IFR	2041	1
RF Signal Generator	Marconi	2041	1
In-line RF Wattmeter	BIRD	4381	1
RF Signal Generator	Rhode&Schwarz		
Digital Phosphor Oscilloscope	Tektronix	3052B	1
Two-Tone Audio Generator	ARRL	N/A	1
Power Attenuator	BIRD	8329	1
Keying-Test Generator	ARRL	N/A	1
Adjustable RF Attenuators	HP	355C/D	1
Hybrid Combiner	Ten-Tec	651 (2-60 MHz)	1
Voltmeter	Bench	N/A	1
Ammeter	Bench	N/A	1
Phase-Noise Mixer	ARRL	N/A	1
14.025 MHz Low-Noise Osc.	ARRL	N/A	1
Power Supply	HP	6268B	1
Telegraph Key	Any	N/A	1
Attenuators	BIRD	8340-100 or similar	As R'qd
HI-Z Audio Monitor Amp	ARRL	N/A	1
Wideband Noise Generator	Elecraft	N-gen	1

Rhode & Schwarz CMT 54 RF Signal Generator

## IV. TRANSMITTER TESTS

4.0.1 As shown in the Table of Contents, there are 11 transmitter tests outlined in this chapter. They have been arranged to minimize the required number of hook-up changes and modifications. However, each hook-up is shown complete, with all changes from the previous test clearly indicated. A block diagram accompanies each hook-up and any changes from the previous test are shown within a dotted rectangle. This affords the flexibility to easily start anywhere within the test plan and to perform these tests in any desired order.

4.0.2 Before any transmitter testing is performed, it is essential for the test engineer to be completely familiar with the Device Under Test (DUT) and the test equipment that will be used. The transmitter output power must not exceed the limitations of any test equipment used or the manufacturer's specifications for the DUT – *including duty cycle or time*. The transmitter must be operated in a manner exactly as specified and be properly tuned. Any test in this manual that would cause a piece of equipment to be operated in a manner inconsistent with its manual must be accordingly modified as required by the test engineer.

4.0.2.1 Other considerations are as follows:

### *Spectrum Analyzer/Frequency Counter*

The input to the spectrum analyzer or frequency counter should not exceed the range of  $-5$  dBm to 0 dBm. Therefore, it is necessary to attenuate the output of transmitters or amplifiers down to this level. For example, if a particular transmitter is rated at 100 watts output, it will be necessary to use 50 dB of attenuation to obtain a level of 0 dBm.

### *RF Power Meter*

The necessary element for the inline RF-power meter must be selected for the expected power and frequency. There are also multiplier switches on the wattmeter. Select the combination of switches that equals the power rating of the element.

### *RF Power and Step Attenuators*

RF power attenuators have an INPUT and an OUTPUT. Make sure that the RF source is connected to the INPUT of the power attenuator. Connecting RF power to the OUTPUT of the attenuator will result in damage to the attenuator or to the transceiver. The attenuators have a power rating, which must be observed. It is always best to be conservative.

## 4.1 OUTPUT POWER TEST

4.1.1 The purpose of the Transmitter Output Power Test is to measure the RF output power of the DUT across each band in each of its available modes. A two-tone audio input, at a level within the manufacturer's microphone-input specifications, will be used for the SSB mode. No modulation will be used in the AM and FM modes. DC current consumption at the manufacturer's specified supply voltage is also measured, if applicable.

4.1.2 Test hook-up (See Fig. 4-1)

4.1.2.1 With all test equipment and DUT power switches in the OFF position and the transceiver in the receive mode, connect the following:

<u>Connection</u>	<u>Connectors</u>	<u>Cable Type</u>
DUT RF OUTPUT to Wattmeter INPUT	As Required to Type N	50-Ohm Coax
Wattmeter OUTPUT to RF Power Attenuator	Type N to Type N	50-Ohm Coax
Two-Tone Audio Generator to DUT Microphone INPUT	Banana or BNC to As Required	Coax
Telegraph Key to DUT KEY INPUT	As Required	As Required
AC power Only/AC Source to DUT Power Input	As Supplied with DUT	As Supplied with DUT
DC Power Only	As Required	As Required

- 1) Power supply to AC source.
- 2) Power supply OUT to voltmeter and ammeter.
- 3) Set power supply to specified voltage and connect to DUT.

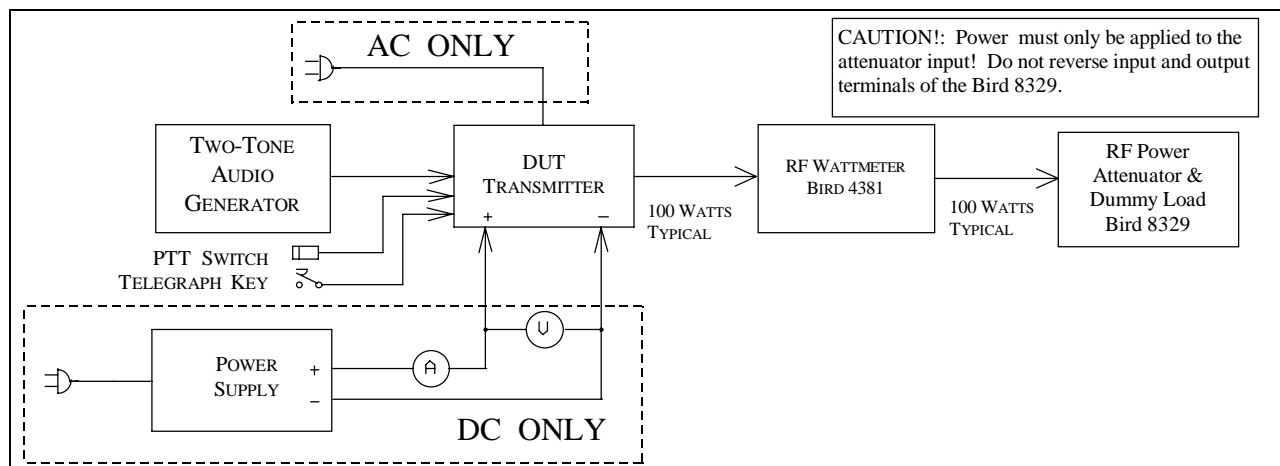

Fig. 4-1 Power Output Test Hook-Up

### 4.1.3 Test Procedure

4.1.3.1 Turn the DUT and RF wattmeter power switches to ON and set the following controls:

<u>Instrument</u>	<u>Control</u>	<u>Position</u>
Two-Tone Audio Generator	TONE A	OFF
	TONE B	OFF
	HI-Z/LO-Z	As Required
	BALANCE	Center
	LEVEL	Full CCW
	Attenuator	-30 dB
RF Wattmeter	Mode Select Button	FWD PEP
	Element	As Required
	Forward Element Range	As Required
DUT	Mode	CW
	BAND Selector	Lowest Available
	XMIT/RCV	Receive
	DRIVE or RF LEVEL	Minimum

4.1.3.2 Allow all equipment at least 10 minutes warm-up time before proceeding to step 4.1.3.3

4.1.3.3 Tune the DUT per the operators manual. Put the DUT in the CW transmit mode at minimum DRIVE/RF LEVEL.

**NOTE:** The following three paragraphs, 4.1.3.4 , 4.1.3.5 and 4.1.3.6 apply only to transceivers with a DC power supply. Skip these paragraphs if testing an ac-powered DUT and make a note of the power type on Data Sheet.

4.1.3.4 Depress telegraph key. Observe that some minimum level of RF power is shown by the DUT Power Output Meter and Bird Wattmeter. Increase the RF DRIVE/LEVEL control if necessary. Record the power-supply ammeter and voltmeter values in 4.1.3.4 of the data sheet.

4.1.3.5 Increase RF DRIVE/LEVEL control to the maximum allowed by the manufacturer. Again, depress the telegraph key and record the power-supply meter readings in 4.1.3.5 of the data sheet. Decrease the RF DRIVE control to minimum. Release the telegraph key.

4.1.3.6 Increase the DUT AF gain control to maximum. (There should be no input signal.) Any light or display illumination should be in the default position. Measure and record the power supply readings as in the previous step.

4.1.3.7 Depress the key and observe the DUT power output meter and wattmeter indications. Slowly tune the DUT to the upper band edge while observing these meters. Release the key and record the maximum value observed on the wattmeter in 4.1.3.7 of the data sheet.

4.1.3.8 Increase the DRIVE/RF LEVEL control to the maximum allowed. Depress the telegraph key. Slowly tune the DUT down to the lower band edge while observing both the DUT power output meter and wattmeter as in the previous step. Release the telegraph key and record the minimum wattmeter values observed in 4.1.3.8 of the data sheet. Return the DRIVE/RF LEVEL control to minimum.

4.1.3.9 Set the DUT for the lower edge of the 80-meter band and retune as necessary. Repeat steps 4.1.3.7 and 4.1.3.8. Record all values in 4.1.3.9 of the data sheet. Repeat this procedure for all the remaining bands. Record both the DUT power output meter and wattmeter indications for the 20-meter band. Note any significant deviations in the DUT meter indication observed between bands.

4.1.3.10 Return the transmitter to the lower edge of the 20-meter band and retune as necessary. Set the two-tone audio generator power switch to ON. Adjust for proper balance between both tones by setting the BALANCE control to the position so indicated. Adjust the generator LEVEL control for maximum specified ALC. Set the RF wattmeter to FWD PEP. Place the DUT in the USB mode and tune as required with the DUT mic gain control set about half-way. Adjust the audio generator for maximum audio as specified by the manufacturer's manual with the DUT mic gain control set about half-way.

4.1.3.11 Repeat steps 4.1.3.7 and 4.1.3.8 and using the PTT switch to key the transmitter. Verify similar power output performance with the DUT in the LSB mode. Note any significant deviation from the USB mode. Record DUT power output meter and wattmeter indications in 4.1.3.11 of the Data Sheets.

4.1.3.12 Set the RF Wattmeter to FWD CW and the two-tone generator power switch to OFF. Return the transmitter to the lower edge of the 80-meter band. Place the DUT in the AM mode. Repeat steps 4.1.3.7 and 4.1.3.8 using the PTT switch to key the transmitter. *Be sure not to exceed the maximum power output specified by the manufacturer for this mode.* Record DUT power output meter and wattmeter indications in 4.1.3.12 of the Data Sheets.

4.1.3.13 Return the transmitter to the lower edge of the 10-meter band. Place the DUT in the FM mode. Repeat steps 4.1.3.7 and 4.1.3.8 for this mode. *Be sure not to exceed the maximum power output specified by the manufacturer for this mode.*

**NOTE:** Proceed to the following step *only* if the DUT has a transverter output.

4.1.3.14 Put the DUT into the CW mode and activate the transverter function.. Set to the 15 meter band. Connect the HP-437 microwatt meter and any needed attenuation to the transverter output. (Input to the microwatt meter must not exceed +20 dBm.) Repeat steps 4.1.3.7 and 4.1.3.8. Record on Data Sheet. Also observe and record any RF output that may appear at the normal antenna output.

## 4.2 TRANSMIT FREQUENCY RANGE TEST

4.2.1 The purpose of the Transmit Frequency Range Test is to determine the range of frequencies, including those outside amateur bands, for which the transmitter may be used.

4.2.2 Test Hook-up (See Fig. 4-2)

**NOTE:** No further hook-up changes are required if proceeding directly from the previous Power Output Test. This hook-up procedure, therefore, does not apply in this case and you may now proceed to step 4.2.3.1.

4.2.2.1 Connect the following with all power switches in the OFF position and the transceiver in the receive mode:

<u>Connection</u>	<u>Connectors</u>	<u>Cable Type</u>
DUT RF OUTPUT to Wattmeter INPUT	As Required to Type N	50-Ohm Coax
Wattmeter OUTPUT to RF Power Attenuator	Type N to Type N	50-Ohm Coax
Telegraph Key to DUT KEY INPUT	As Required	As Required
AC power Only/AC Source to DUT Power Input	As Supplied with DUT	As Supplied with DUT
DC Power Only	As Required	As Required
1) Power supply to AC source.		
2) Power supply OUT to voltmeter and ammeter.		

3) Set power supply to specified voltage and connect to DUT.

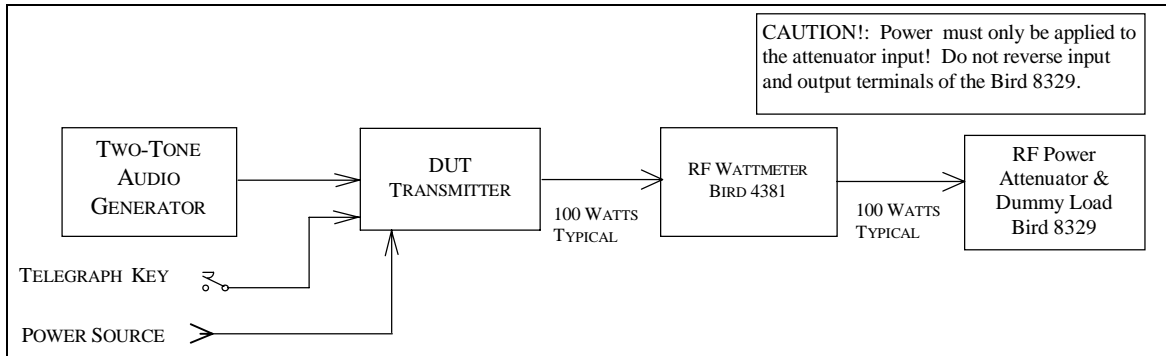

Fig. 4-2 — Transmit Frequency Range Test Hook-up

### 4.2.3 Test Procedure

4.2.3.1 Turn the DUT and RF wattmeter power switches to ON and set the following controls:

<u>Instrument</u>	<u>Control</u>	<u>Position</u>
RF Wattmeter	Mode select button Element Power Range	FWD CW As Required As Required
DUT	Mode Band Selector XMIT/RCV DRIVE/RF OUT	CW Lowest available band RECEIVE Minimum

4.2.3.2 Allow all equipment at least 10 minutes warm up time.

4.2.3.3 Tune the DUT per the operators manual for the lowest available band. Return the DRIVE/RF OUTPUT control to minimum. (The DUT should still be in the CW mode.)

4.2.3.4 Tune down near the low end of the band. Depress the telegraph key. Observe some minimum RF indication on the wattmeter. Slowly tune down until the RF drops out or the manufacturer's specified limit is achieved. Release the key and record this frequency, as indicated by the DUT display in 4.1.3.4 of the data sheet.

4.2.3.5 Tune to the upper limit of the band. Again, depress the telegraph key and slowly tune up until the RF drops out. Release the key and record this frequency in 4.1.3.5 of the data sheet.

4.2.3.6 Repeat steps 4.1.3.3 to 4.1.3.5 for all remaining available bands on the DUT.

## 4.3 CW TRANSMIT-FREQUENCY ACCURACY TEST

4.3.1 The purpose of the CW Transmit-Frequency Accuracy Test is to measure and compare the actual output frequency of the DUT with it's display adjusted for 14.000 MHz down to the least significant available digit.

4.3.2 TEST HOOK-UP (See Fig. 4-3)

**NOTE:** If proceeding directly from the previous Transmit Frequency Range Test, you need only modify the existing hook-up. Proceed to the steps indicated with a dotted line.

4.3.2.1 With all power switches in the OFF position and the transceiver in the receive mode, connect the following:

<u>Connection</u>	<u>Connectors</u>	<u>Cable Type</u>
DUT RF OUTPUT to wattmeter INPUT	As Required to type N	50-Ohm coax
Wattmeter OUTPUT to Power Attn INPUT	Type N to type N	50-Ohm coax
-----		
Pwr Attn OUT to 10-dB step INPUT	Type N to BNC	50-Ohm coax
10-dB step Attn OUT to 1-dB step IN	BNC to BNC	50-Ohm coax
1-dB step ATTN OUT to Freq Counter IN	BNC to BNC	50-Ohm coax
-----		
Telegraph key to DUT KEY INPUT	As Required	As Required
AC or DC power to DUT	As Required	As Required

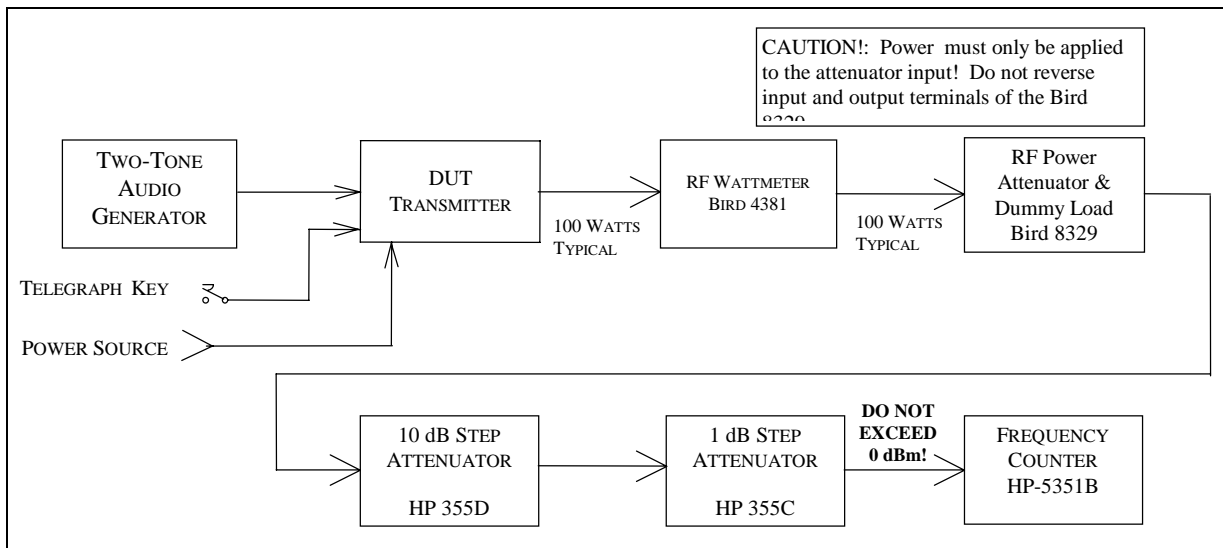

Fig. 4-3 — CW Transmit Accuracy Test Hook-up

### 4.3.3 Test Procedure

4.3.3.1 Turn the DUT, RF wattmeter and frequency counter power switches to ON. Set the following controls:

<u>Instrument</u>	<u>Control</u>	<u>Position</u>
DUT	Mode	CW
	Band Selector	20 Meters
	Frequency	14.000 00 MHz
	XMIT/RCV	RECEIVE
	DRIVE/RF OUT	Minimum
RF Wattmeter	Mode Select Button	FWD CW
	Element	As Required
	Power Range	As Required
10-dB Step Attn	Attenuator	40 dB
1-dB Step Attn	Attenuator	Any
Frequency Counter	50 Ohm	50 Ohm (Depress)

4.3.3.2 Key the transmitter. Observe the minimum output power on the RF wattmeter and unkey the transmitter. Set the step attenuators to provide –5 to 0 dBm input to the frequency counter.

**Do not exceed the maximum input limitation to the Frequency Counter.**

4.3.3.3 Check and readjust, if necessary, the DUT for 14.000 00 MHz as indicated by its display. Record this value if the DUT has a digital type display, or, as best as possible with an analog display.

4.3.3.4 Key the transmitter and note the frequency as indicated by both the DUT and the frequency counter. Place a check mark in 4.3.3.4 of the data sheet if there is any significant deviation from 14.000 00 MHz

4.3.3.5 Increase the step attenuators to 40 dB. Set the transmitter power to the maximum allowed. Key the transmitter and observe the RF output power as shown by the wattmeter. Set the attenuators to provide –5 to 0 dBm input to the counter.

4.3.3.6 Key the transmitter. Record the DUT and Frequency Counter indications in 4.3.3.6 of the Data Sheet. Unkey the transmitter.

4.3.3.7 Reduce the voltage to 12 V dc (if using a DC supply). Again key the transmitter and note the frequency displayed on the DUT and frequency counter. Place a check mark in 4.3.3.7 of the data sheet if there is any significant deviation from initial data.

#### 4.4 SPECTRAL PURITY TEST

4.4.1 The purpose of the Spectral Purity Test is to determine and measure the content of any spurious emissions in the output of the transmitter. Full-power carriers will be examined and minimum power checked on all available bands.

##### 4.4.2 Test hook-up (See Fig. 4-4)

**NOTE:** If proceeding from the previous Transmit Frequency Accuracy Test, skip to the steps indicated with a dotted line.

4.4.2.1 With all power switches in the OFF position and the transceiver in the receive mode, connect the following:

<u>Connection</u>	<u>Connectors</u>	<u>Cable Type</u>
DUT RF OUTPUT to wattmeter INPUT	As Required to type N	50-Ohm coax
Wattmeter OUTPUT to Power Attn INPUT	Type N to type N	50-Ohm coax
Power Attn OUT to 10-dB step INPUT	Type N to BNC	50-Ohm coax
10-dB step Attn OUT to 1-dB step IN	BNC to BNC	50-Ohm coax
-----		
1-dB step Attn OUT to Spec Analyzer IN	BNC to BNC	50-Ohm coax
-----		
Telegraph key to DUT KEY INPUT	As Required	As Required
AC or DC power to DUT	As Required	As Required

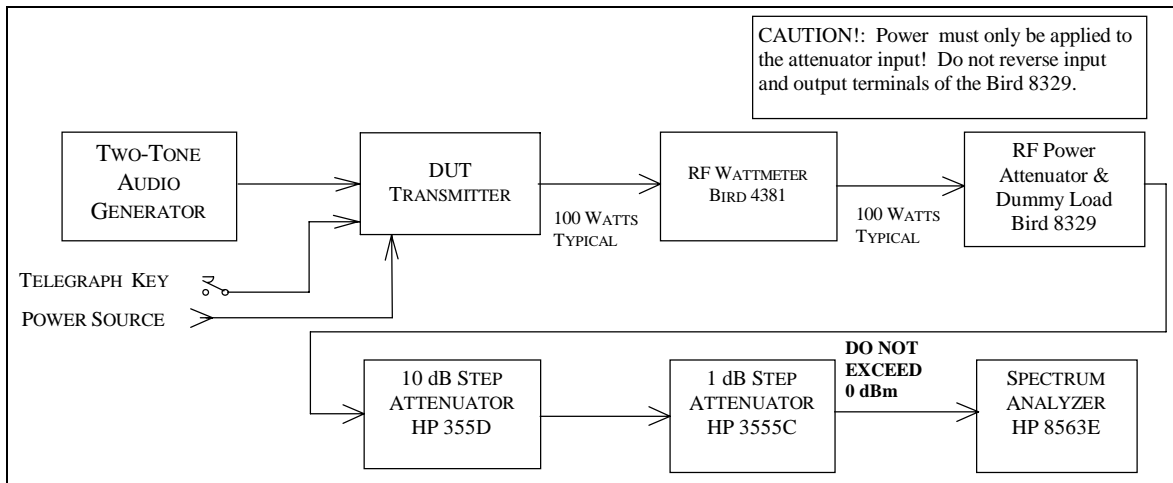

Fig. 4-4 — Spectral Purity Test Hook-up

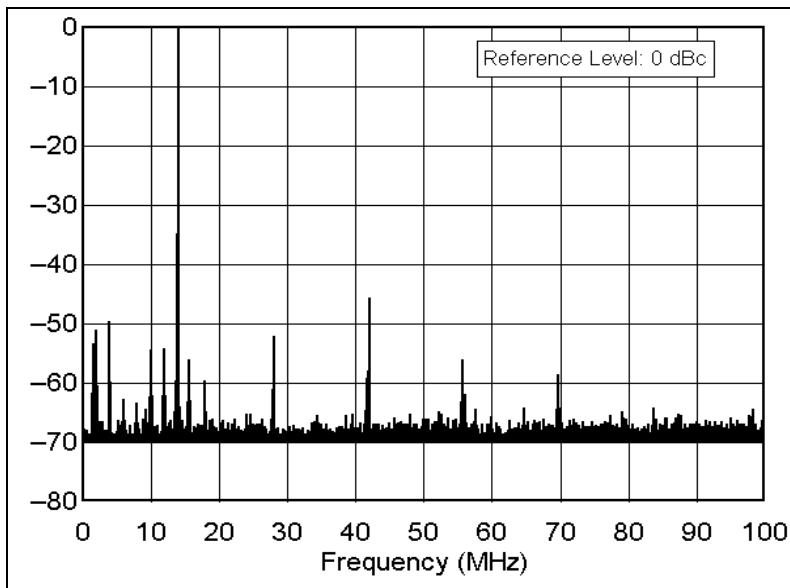

Fig. 4-4A — Example Spectral Purity Plot

#### 4.4.3 Test Procedure

4.4.3.1 Turn the DUT, RF wattmeter and spectrum analyzer power switches to ON and set the following controls:

<u>Instrument</u>	<u>Control</u>	<u>Position</u>
DUT	Mode	CW
	Band Selector	Lowest available
	XMIT/RCV	Receive
	DRIVE/RF LEVEL	Minimum
RF Wattmeter	Push Button Mode Select	FWD CW
	Element	As Required
	Forward Element Range	As Required
10-dB Step Attn	Attenuator	40 dB
1-dB Step Attn	Attenuator	Any
Spectrum Analyzer	START FREQ - STOP FREQ	0 – 50 MHz
	REF LEV (AMPLITUDE)	-10 dBm
	ATTEN (AMPLITUDE)	20 dB
	RES BW (BW)	10 kHz
	VIDEO BW (BW)	30 kHz
	THRESHOLD (DISPLAY)	-80 dBm
	SWP TIME (SWEEP)	AUTO

4.4.3.2 **NOTE:** If proceeding directly from the previous CW Transmit Frequency Accuracy Test, skip this paragraph.

Receiver hiss should be heard; adjust volume to desired level. Allow all equipment at least 10 minutes warm-up time before proceeding to step 4.4.3.3.

4.4.3.3 Tune the DUT per the operator's manual at the low end of the band. Put the DUT in the CW transmit mode at maximum DRIVE/RF LEVEL.

4.4.3.4 Depress the telegraph key and observe the power output shown by the Bird wattmeter. Release the key and set the step attenuators for -10 dBm input to the spectrum analyzer. *CAUTION: The input to the spectrum analyzer at no time should exceed +10 dBm. Damage to this instrument will occur at an input level of +30 dBm or greater.*<sup>1</sup>

4.4.3.5 Key the transmitter. The largest pip to the right of 0 MHz should be the fundamental. (This may be verified by use of the PEAK SEARCH button. With the marker to be at the top of the pip, the indicated marker frequency should be very close to the transmitted frequency.)

4.4.3.6 Adjust the REF LEV control on the spectrum analyzer so that the peak of the fundamental pip is at the Log Ref (0 dB) line on top of the display graticule. (To optimize the display, the FREQ START-FREQ STOP may be set for 0-10 MHz and the RES BW may be set for 30 kHz on the 160-meter band.)

4.4.3.7 The spectrum analyzer is now calibrated. The smaller pips are harmonics or spurs. The level of each spur, in dB below the fundamental, can be read directly from the display graticule. Each horizontal division represents 5 MHz each in the case of a 0-50 MHz frequency range. The frequency range may be adjusted for the specific display being considered, or as deemed appropriate by the test engineer. Each vertical division represents 10 dB.

4.4.3.8 Turn on the crystal calibrator, if the DUT has one, and observe any spurious emissions created by the calibrator. Record in notes section of data sheet and turn off the calibrator.

4.4.3.9 Slowly tune up the band while observing the analyzer display. Retune as necessary if the transmitter is not a broadband type. Note the worst case observed. Record on data sheet.

4.4.3.10 Reduce the transmitter power output to minimum. Again, observe the analyzer display while tuning down to the lower band edge. Note the worst case observed and record on data sheet.

4.4.3.11 Repeat steps 4.4.3.9 and 4.4.3.10 for all remaining available bands on the DUT. The Frequency Range settings for each band are as follows:

1.8 MHz	0-50 MHz
14 MHz	0-100 MHz
28 MHz	0-200 MHz
50 MHz	0-500 MHz
144 MHz	0-1000 MHz
222 MHz	0-1000 MHz
432 MHz:	0-2000 MHz

4.4.3.12 Return the transmitter to the worst case on the worst band. With the all significant spurs visible on the screen, take a single sweep by depressing the SGL SWP button. (Typically, this will be the second or third harmonic, although it is possible for VHF parasitics to be present.) The START FREQ, STOP FREQ and RES BW may be varied as required. Record all information on data sheet and save the plot to an appropriately named file.

---

<sup>1</sup> "Woe be unto he who breaks this thing." — Edward F. Hare, W1RFI

## 4.5 TWO-TONE TRANSMIT IMD TEST

4.5.1 The purpose of the Two-Tone Transmit Test is to measure the intermodulation-distortion (IMD) products present in the RF output of the DUT transmitter. The transmitter will be operated in the SSB mode at 3.900 MHz and 14.250 MHz initially and then on all other available bands subsequently. A two-tone audio input at frequencies of 700 and 1900 Hz, within the manufacturer's amplitude specifications, will be used.

### 4.5.2 Test hook-up (See Fig. 4-5)

**NOTE:** If proceeding in the test series, only the two-tone generator, shown within the dotted line, must be added to the previous Spectral Purity Test hook-up for the IMD Test.

#### 4.5.2.1 With all power switches in the OFF position and the transceiver in the receive mode, connect the following:

<u>Connection</u>	<u>Connectors</u>	<u>Cable Type</u>
DUT RF OUT To Wattmeter IN	As Required To Type N	50-Ohm Coax
Wattmeter OUT To PWR Attn IN	Type N To Type N	50-Ohm Coax
PWR Attn OUT To 10-dB Step IN	Type N To BNC	50-Ohm Coax
10-dB Step OUT To 1-dB Step IN Coax	BNC To BNC	50-Ohm
<hr/>		
<u>Connection</u>	<u>Connectors</u>	<u>Cable Type</u>
1-dB Step OUT To Spectrum Analyzer IN	BNC To BNC	50 Ohm Coax
<hr/>		
Two-Tone Generator OUT To DUT MIC IN	BNC To As Required	Coax
<hr/>		
Power to DUT	As Required	As Required

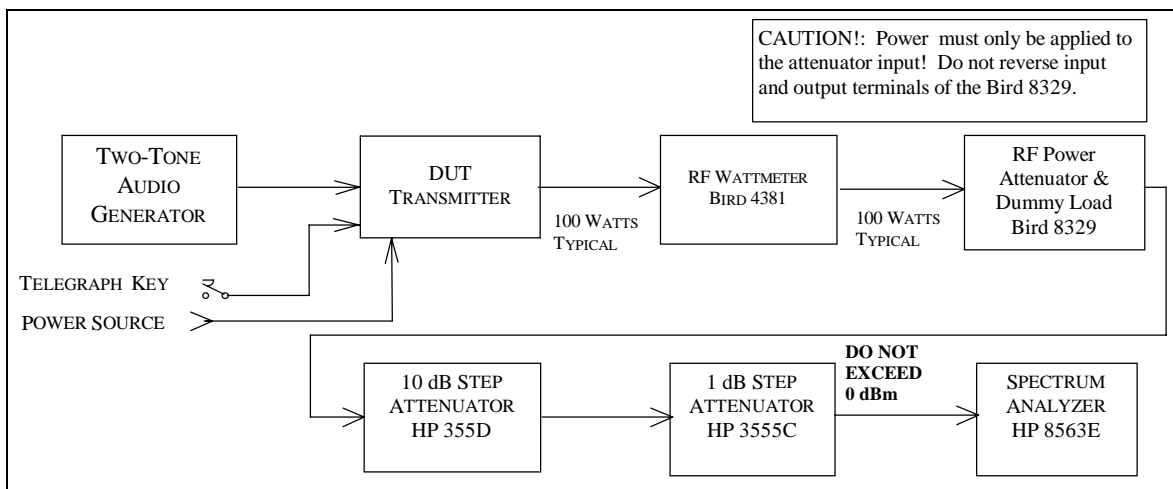

Fig. 4-5 — Two-Tone Transmit IMD Test Hook-up

### 4.5.3 Test Procedure

4.5.3.1 Turn on the DUT, RF wattmeter and spectrum analyzer and set the following controls:

<u>Instrument</u>	<u>Control</u>	<u>Position</u>
DUT	Mode	LSB
	Band Selector	80 Meters

	Frequency	3.900 00 MHz
	XMIT/RCV	RECEIVE
	DRIVE or RF LEVEL	Minimum
	Microphone	Minimum
Two-Tone Generator	TONE A (700 Hz)	OFF
	TONE B (1900 Hz)	OFF
	HI-Z/LO-Z	As Required
	BALANCE	Center
	LEVEL	Full CCW
	Attenuator	-30 dB
RF Wattmeter	Push Button Mode Select	FWD PEP
	Element	As Required
	Forward Element Range	As Required
10-dB Step Attn	Attenuator	-40 dB
1-dB Step Attn	Attenuator	Any
Spectrum Analyzer (Menu in Parentheses)	CENTER FREQ (FREQUENCY)	3.89870 MHz
	SPAN (SPAN)	20 kHz
	REF LEV (AMPLITUDE)	-40 dBm
	ATTEN (AMPLITUDE)	20 dB
	RES BW (BW)	100 Hz
	VIDEO BW (BW)	10 kHz
	THRESHOLD (DISPLAY)	-110 dBm
	SWP TIME (SWEEP)	AUTO

4.5.3.2 **NOTE:** If proceeding from the previous tests, this paragraph may be skipped.

Receiver hiss should be heard; adjust the volume to the desired level. Allow all equipment at least 10 minutes warm-up time before proceeding to step 4.5.3.3.

4.5.3.3 Tune the DUT per the operator's manual for the test frequency of 3.900 MHz. Turn on the two-tone generator and set both tone switches to ON. With the DUT in the LSB mode, set the generator LEVEL and ATTENUATOR controls for the maximum audio input as specified by the manufacturer. If the manufacturer does not list a specification for this figure, adjust the 2-tone generator's amplitude for maximum rated RF output of the transmitter with the transmitter's microphone gain near maximum. Observe the transmitter power as shown by the wattmeter. Ensure that the output power of the DUT is not greater than the manufacture's maximum power output rating. Unkey the transmitter and set the step attenuators for approximately -46 dBm input to the spectrum analyzer.

**CAUTION:** The input to the spectrum analyzer at no time should exceed +10 dBm.

4.5.3.4 Place the DUT in the VOX mode and verify operation with the signal generator. Note on data sheet if VOX does not function correctly. Return the DUT to the PTT mode and key the transmitter. Set the BALANCE control on the generator for equal tone amplitude as shown on the display. Adjust the CENTER FREQ, if necessary, so that the display center is half-way between the two pips. The IMD-distortion products should now be visible.

4.5.3.5 Adjust the REF LEVEL control (and step attenuators, if necessary) for the peak of the two pips to be at -6 dB. The spectrum analyzer is now calibrated. The amplitude of each IMD distortion product may now be read in dB PEP (dB below the peak envelope power) directly from the display.

4.5.3.6 Manipulate, if necessary, the two-tone generator audio LEVEL and the transmitter audio gain and drive control to obtain the lowest possible IMD products. If this is done, the spectrum analyzer REF LEVEL control (and possibly the step attenuators) may need to be reset for tone pips of -6 dB.

4.5.3.7 Set the SWP TIME (in the SWEEP menu) for 6 seconds. Take a single sweep by depressing the SGL SWEEP button. Record all info on data sheet. Print and save to an appropriate file name.

4.5.3.8 Set and tune the transmitter for USB at a frequency of 14.250 MHz. Set the CENTER FREQ for 14.25130 MHz. and return the SWP TIME back to AUTO. Repeat paragraphs 4.5.3.3 to 4.5.3.7 for this frequency.

4.5.3.9 Repeat step 4.5.3.8 for the following frequencies (if applicable to the DUT): 1.850 MHz, 7.250 MHz, 10.120 MHz, 18.120 MHz, 21.250 MHz, 24.950 MHz, 28.350 MHz, 50.200 MHz, 144.200 MHz and 432.200 MHz.

#### **4.6 SSB CARRIER AND UNWANTED SIDEBAND SUPPRESSION AT 14.250 MHz**

4.6.1 The purpose of the SSB Carrier and Unwanted-Sideband Suppression Test is to determine the level of suppression of the unwanted sideband and carrier relative to Peak Envelope Power (PEP). The transmitter output is observed on the spectrum analyzer and the unwanted components are compared to the desired sideband.

4.6.2 Test hook-up (See Fig. 4-6)

**NOTE:** No changes in hook-up are required if proceeding directly from the previous Two-Tone Transmit IMD Test, proceed now, in this case, to paragraph 4.6.3.

4.6.2.1 With all power switches in the OFF position and the transceiver in the receive mode, connect the following:

<u>Connection</u>	<u>Connectors</u>	<u>Cable Type</u>
DUT RF OUT To Wattmeter IN	As Required To Type N	50-Ohm Coax
Wattmeter OUT To PWR Attn IN	Type N To Type N	50-Ohm Coax
PWR Attn OUT To 10-dB Step IN	Type N To BNC	50-Ohm Coax
10-dB Step OUT To 1-dB Step IN	BNC to BNC	50-Ohm Coax
1-dB Step OUT To Spec Analyzer IN	BNC To BNC	50-Ohm Coax
Two-Tone Generator OUT to DUT MIC IN	BNC to As Required	Coax

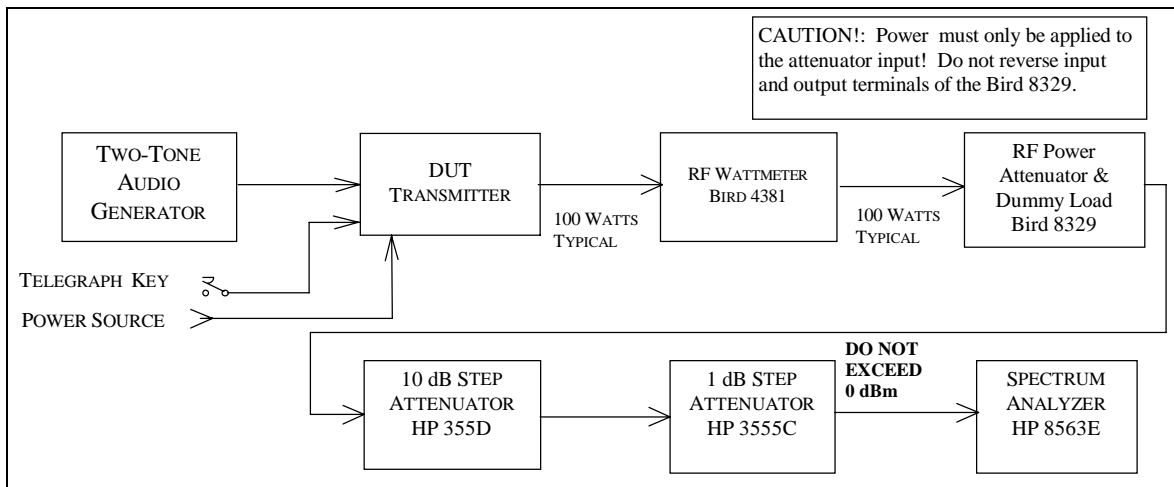

Fig. 4-6 — SSB Carrier and Unwanted Sideband Suppression Test Hook-up

### 4.6.3 Test Procedure

4.6.3.1 Turn the DUT, RF wattmeter and spectrum analyzer power switches to ON and set the following controls:

<u>Instrument</u>	<u>Control</u>	<u>Position</u>
DUT	Mode	USB
	Band Selector	20 Meters
	Frequency	14.250 MHz
	XMIT/RCV	Receive
	DRIVE or RF LEVEL	Minimum
	Microphone	Minimum
<u>Instrument</u> Two-Tone Generator	<u>Control</u> TONE A (700 Hz)	<u>Position</u> OFF
	TONE B (1900 Hz)	OFF
	HI-Z/LO-Z	As Required
	BALANCE	Center
	LEVEL	Full CCW
	Attenuator	-30 dB
RF Wattmeter	Push Button Mode Select	FWD PEP
	Element	As Required
	Forward Element Range	As Required
10-dB Step Attn	Attenuator	-40 dB
1-dB Step Attn	Attenuator	Any
Spectrum Analyzer	CENTER FREQ (FREQUENCY)	14.25130 MHz
	SPAN (SPAN)	20 kHz
	REF LEV (AMPLITUDE)	-40 dBm
	ATTEN (AMPLITUDE)	20 dB
	RES BW (BW)	100 Hz
	VIDEO BW (BW)	10 kHz
	THRESHOLD (DISPLAY)	OFF
	SWP TIME (SWEEP)	AUTO

4.6.3.2 **NOTE:** If proceeding from the previous tests, this paragraph may be skipped.

Receiver hiss should be heard; adjust the volume to the desired level. Allow all equipment at least 10 minutes warm-up time before proceeding to step 4.6.3.3.

4.6.3.3 Tune the DUT per the operator's manual for the test frequency of 14.250 MHz. Turn on the two-tone generator and set the TONE B switch to ON. With the DUT in the USB mode, adjust the MIC gain and set the generator LEVEL and ATTENUATOR controls for the maximum audio input as specified by the manufacturer. Observe the transmitter output power as shown by the wattmeter. Unkey the transmitter and set the step attenuators for -40 dBm input to the spectrum analyzer.

*CAUTION: The input to the spectrum analyzer at no time should exceed +10 dBm. Damage to the instrument will occur at an input level of +30 dBm or greater.*

4.6.3.4 Key the transmitter. Adjust the DUT USB signal frequency to 14.2532 MHz on the spectrum analyzer display.

4.6.3.5 A tiny low level pip may appear 1900 Hz to the left of the USB signal at the center of the spectrum analyzer display. This is the suppressed carrier. Another pip, if visible 3800 Hz to the left of the USB (at 14.2494 MHz) is the unwanted Lower Sideband (LSB). This may be verified by keying the transmitter off and on again. All pips from the DUT will disappear. If necessary, adjust the CENTER FREQ control so that the USB pip is centered (or nearly centered) on the display graticule.

4.6.3.6 Adjust the REF LEV control (and step attenuators if required) so that the peak of the USB pip is at 0 dB. The spectrum analyzer is now calibrated. Press the SGL SWEEP button for a single trace. The amplitude of the unwanted sideband and carrier may now be read in dB below Peak Envelope Power (PEP) directly from the display.

4.6.3.7 Record the value of both the suppressed carrier and the unwanted sideband in 4.6.3.7 of the Data Sheet.

4.6.3.8 Set the transmitter mode switch for LSB. Return the SWP TIME to AUTO. Repeat paragraphs 4.6.3.4 to 4.6.3.7 for the lower sideband at 14.2494 MHz (the suppressed carrier and unwanted upper sideband now appear to the right of the lower sideband at 14.2513 and 14.2532 MHz, respectively). If the pip is lost when the mode is changed, it may also be necessary reset the CENTER FREQ control. Record results in 4.6.3.8 of the data sheet.

4.6.3.9 If the DUT also has any VHF or UHF outputs, set the DUT to approximately 200 kHz above the bottom of each band and repeat paragraphs 4.6.3.3 to 4.6.3.8, adjusting the spectrum analyzer center frequency as appropriate (Examples: for 6M, use a center frequency of 50.2013; the USB signal will appear at 50.2032 and the LSB signal at 50.1994; for 2M, use a center frequency of 144.2013; the USB signal will appear at 144.2032 and the LSB signal at 144.1994).

## **4.7 CW KEYING WAVEFORM TEST**

4.7.1 The purpose of the CW Keying Waveform Test is to photograph the first and second dit in a series of dits with the DUT in the VOX and QSK modes. The keying rate is 20 ms on and 20 ms off, a rate that corresponds to 60 WPM using the PARIS standard. A picture will also be taken of any other test conditions that result in any waveshape that is significantly different from the others (more than 10% difference, spikes, etc.).

4.7.2 Test hook-up (See Fig. 4-7)

**NOTE:** If proceeding from the previous SSB Carrier and Unwanted Sideband Test, only the hook-up modifications indicated with a dotted line need to be implemented for this test.

4.7.2.1 With all power switches in the OFF position and the transceiver in the receive mode, connect the following:

<u>Connection</u>	<u>Connectors</u>	<u>Cable Type</u>
DUT RF OUTPUT to wattmeter INPUT	AS Required to type N	50-Ohm coax
Wattmeter OUTPUT to Power Attn INPUT	Type N to type N	50-Ohm coax
Power Attn OUT to 10-dB step INPUT	Type N to BNC	50-Ohm coax
10-dB step Attn OUT to 1-dB step IN	BNC to BNC	50-Ohm coax
1-dB step Attn OUT to CH2 Scope IN	BNC to BNC	50-Ohm coax
-----		
Key Test Gen OUT to Scope EXT TRIG IN	BNC to BNC	50-Ohm coax
Key Test Gen KEY OUT to DUT KEY IN	BNC to As Required	50-Ohm coax
XMTR Key Line to Scope CH1 INPUT	Probe clip to BNC	10X Probe
Scope GND to XMTR GND	As Required	As Required
-----		
Power to DUT	As Required	As Required

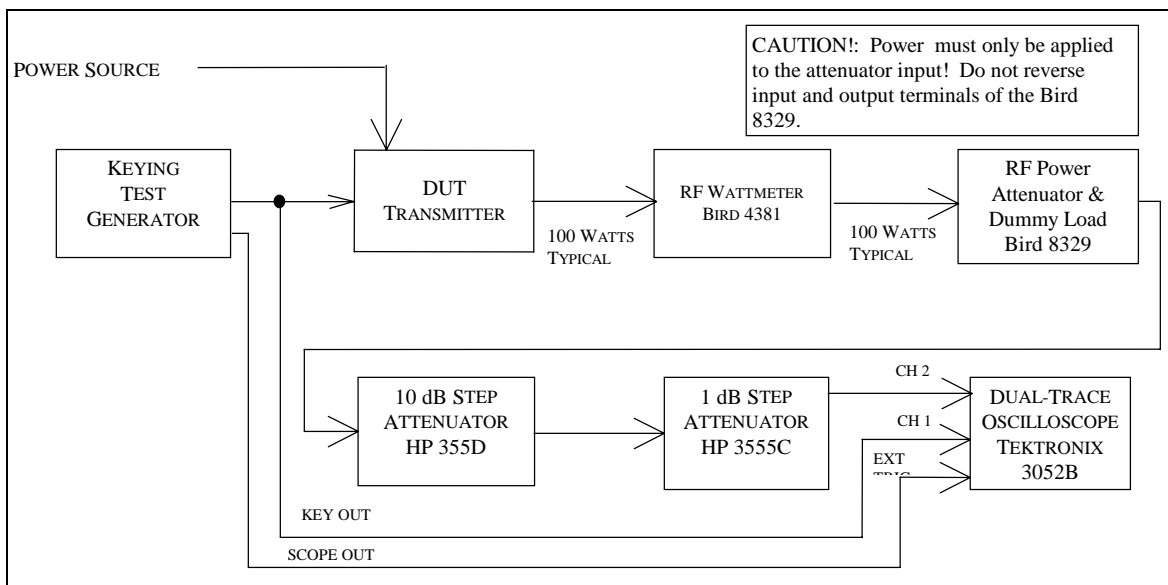

Fig. 4-7 — CW Keying Waveform Test Hook-up

### 4.7.3 Test Procedure

#### 4.7.3.1 Turn the DUT, RF wattmeter and oscilloscope power switches to ON. Set the following controls:

<u>Instrument</u>	<u>Control</u>	<u>Position</u>
DUT	Mode	CW
	Band Selector	20 Meters
	Frequency	14.020 MHz
	XMIT/RCV	Receive
	Drive or RF Level	Maximum
	Keying Mode	VOX
	RF Wattmeter	Push-button Mode Select
	Element	As Required

	Forward Element Range	As Required
10-dB Step Attn	Attenuator	-40 dB
1-dB Step Attn	Attenuator	Any
Keying Test Generator	OUTPUT	OFF
	RANGE	1-99 MS
	KEY DOWN	20
	KEY UP	20
Oscilloscope	CH1 VOLTS/DIV	500 mV
	CH1 Coupling	DC
	CH1 Position	As Needed
	CH2 VOLTS/DIV	1 V
	CH2 Coupling	DC
	CH2 Position	As Needed
	TIME/DIV	10 MS
	Trigger Coupling	DC
	Trigger Source	External
	Trigger Level	As Required

4.7.3.2 Set the keying test generator to ON. Allow all equipment at least 10 minutes warm-up time before proceeding.

4.7.3.3 Tune the DUT, if necessary, *exactly* per the operator's manual for the 14.250 MHz test frequency. Set for maximum power output.

4.7.3.4 Set the keying test generator OUTPUT to ON. Adjust the oscilloscope for a display trace similar to Fig. 4-7A. Note: If the keying generator pulse train shows capacitive shaping, this is due to the configuration of the DUT's keying input circuit and should be considered normal. Be sure that the RF-power level of the dit is approximately the same as the carrier level.

4.7.3.5 Capture the first dit and second dit in a string of dits by using the single-trigger mode of the oscilloscope. Turn the keying generator OFF then ON again to facilitate the string of dits. (NOTE: Some transmitters will lose or chop the first dit of a word).

4.7.3.7 Repeat steps 4.7.3.5 and 4.7.3.6 for QSK ON, and any other keying mode deemed appropriate by the Test Engineer. Also photograph the results of any mode of operation that results in a waveshape that is significantly different (>10% difference, spikes, etc.).

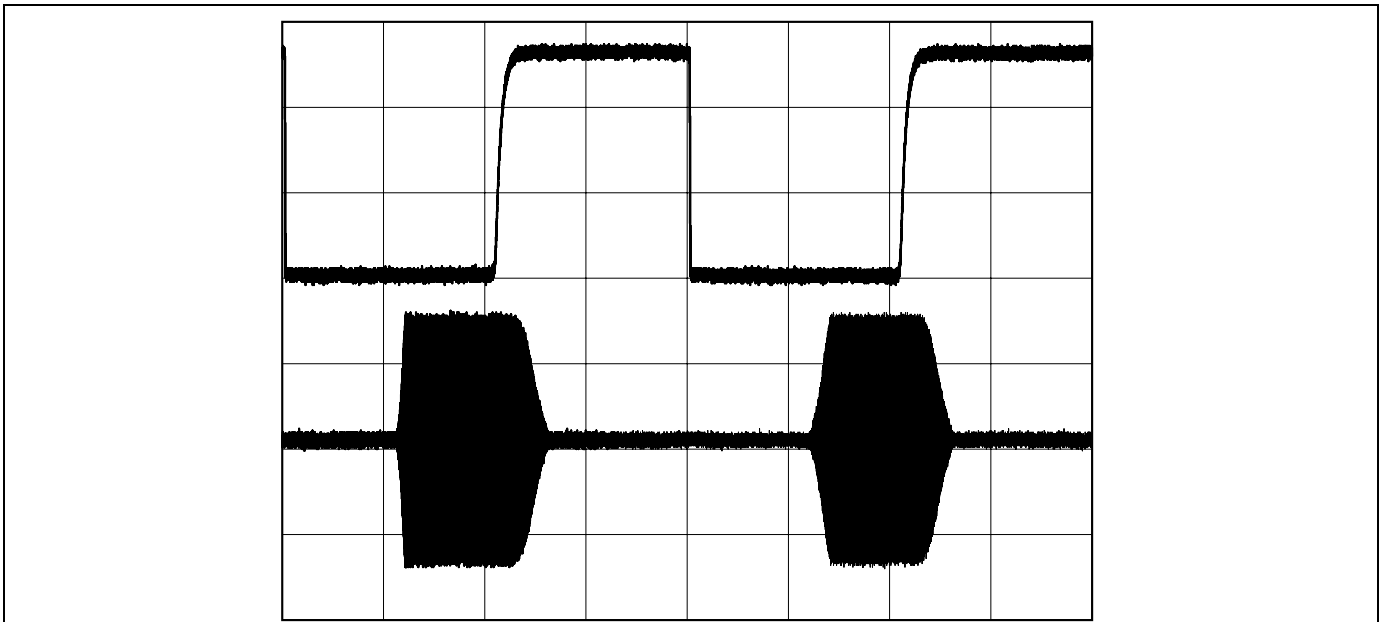

Fig. 4-7A — Oscilloscope Trace of RF Output Envelope

#### 4.8 PTT TO SSB/FM RF OUTPUT TEST

4.8.1 The purpose of the PTT To SSB/FM RF Output Time Test is to determine the key time to RF output delay for the waveform 50% points in the SSB and FM modes. In the SSB mode, audio at a frequency of 700 Hz, and a level within the manufacturer's specified limits, will be applied to the DUT's mic input terminals. The FM mode is tested with an unmodulated carrier.

##### 4.8.2 Test hook-up (See Fig. 4-8)

**NOTE:** If proceeding from the previous CW Keying Waveform Test, only the hook-up modifications indicated with a dotted line need to be implemented for this test.

4.8.2.1 With all power switches in the OFF position and the transmitter in the receive mode, connect the following:

<u>Connection</u>	<u>Connectors</u>	<u>Cable Type</u>
DUT RF OUTPUT to Wattmeter INPUT	As Required to type N	50-Ohm coax
Wattmeter OUTPUT to Power Attn INPUT	Type N to type N	50-Ohm coax
Power Attn OUT to 10-dB step INPUT	Type N to BNC	50-Ohm coax
10-dB step Attn OUT to 1-dB step IN	BNC to BNC	50-Ohm coax
1-dB step Attn OUT to CH2 Scope IN	BNC to BNC	50-Ohm coax
Key Test Gen OUT to Scope EXT TRIG IN	BNC to BNC	50-Ohm coax
Two-Tone Gen OUT to DUT MIC INPUT	Banana to As Required	Coax
-----		
Key Test Gen Key OUT to DUT PTT IN	BNC to As Required	50-Ohm coax
XMTR PTT Key Line to Scope CH1 IN	BNC to BNC	10X Probe
Power to DUT	As Required	As Required

Scope GND to XMTR GND

As Required

As Required

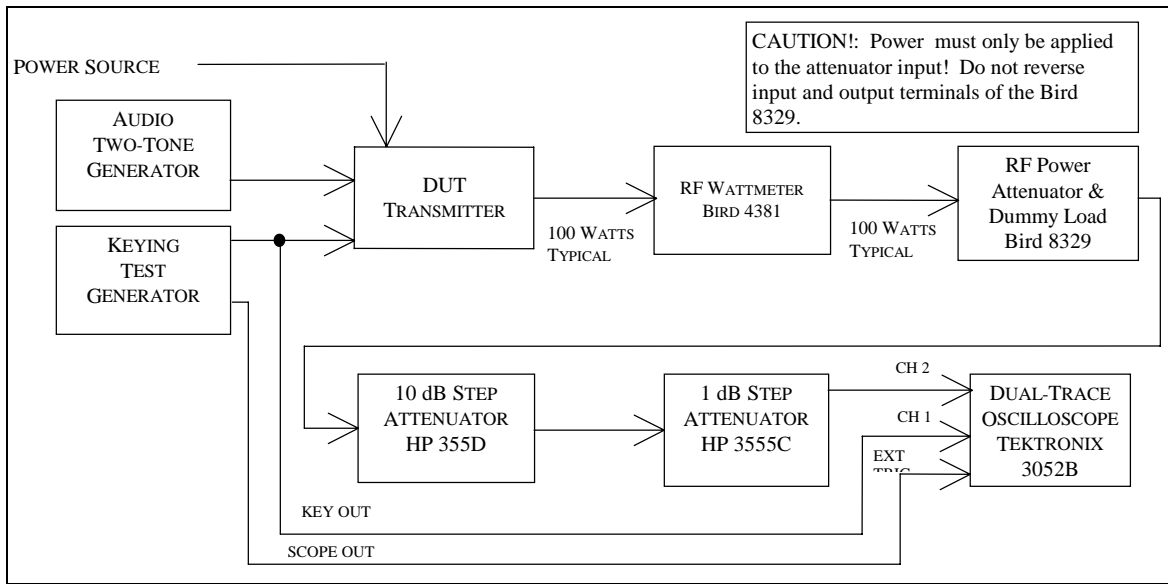

Fig. 4-8 — PTT SSB/FM RF Output Test Hook-up

### 4.8.3 Test procedure

4.8.3.1 Turn the DUT, RF wattmeter and oscilloscope power switches to ON. Set the following controls:

<u>Instrument</u>	<u>Control</u>	<u>Position</u>
DUT	Mode	USB
	Band Selector	20 Meters
	Frequency	14.250 MHz
	XMIT/RCV	Receive
	DRIVE or RF LEVEL	Minimum
	VOX	Off
RF Wattmeter	Mode Select Button	FWD PEP
	Element	As Required
	Forward Element Range	As Required
10-dB Step Attn	Attenuator	-40 dB
1-dB Step Attn	Attenuator	Any
Keying Test Generator	OUTPUT RANGE	OFF
	KEY DOWN	1-99 MS
	KEY UP	20
	KEY UP	20
Two-Tone Generator	TONE A	ON
	TONE B	OFF
	HI-Z/LO-Z	As Required
	BALANCE	N/A
	LEVEL	Full CCW
	ATTENUATOR	-30 dB
Oscilloscope	CH1 VOLTS/DIV	500 mV

CH1 Coupling	DC
CH1 Position	As Needed
CH2 VOLTS/DIV	1 V
CH2 Coupling	DC
CH2 Position	As Needed
TIME/DIV	5 MS
Trigger Mode	AUTO
Trigger Coupling	DC
Trigger Source	EXT
Trigger Level	As Required

4.8.3.2 Set the Two-Tone and Keying Test Generator power switches to ON. Receiver hiss should be heard; adjust volume to desired level. Allow all equipment at least 10 minutes warm-up time before proceeding to step 4.8.3.3

4.8.3.3 Tune the DUT transmitter, if necessary, *exactly* per the operator's manual for the 14.250 MHz test frequency. Adjust the two-tone generator OUTPUT level to the manufacturer's specified limit. Set the DUT for maximum rated power output.

4.8.3.4 Turn the keying test generator OUTPUT to ON. Adjust the oscilloscope for a display trace similar to Fig. 4-8A. It may be necessary to reduce the generator keying speed. Be sure that the RF power level of the Dit is approximately the same as the carrier level.

4.8.3.5 Measure the ON and OFF delay times between the 50% points of the keying pulse and the RF output pulse. Take a single sweep. Adjust the oscilloscope's sweep rate and horizontal position for optimum display results. It is often best to determine the on and off delay times from two different traces. The Trigger Level adjustment can be used to facilitate an easy transition between ON and off delay traces. Record both values in 4.8.3.5 of the data sheet. Turn off the two-tone and keying test generator outputs.

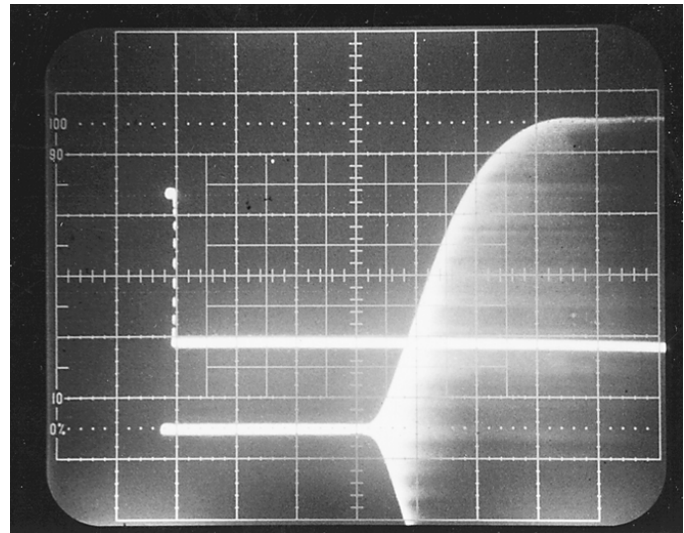

Fig. 4-8A — Oscilloscope Trace of RF Envelope

4.8.3.6 Place the DUT in the FM mode. Repeat paragraphs 4.8.3.3, 4.8.3.4 and 4.8.3.5 for this mode at a test frequency of 29.000 MHz . Record the results in 4.8.3.6 of the data sheet.

4.8.3.7 Repeat step 4.8.3.6 for test frequencies of 52.000 MHz, 146.000 MHz and 440.000 MHz, as appropriate.

## 4.9 TRANSMIT/RECEIVE TURN-AROUND TIME TEST (Transceivers Only)

4.9.1 The purpose of the Transmit/Receive Turn-Around Time Test is to measure the time delay required for a transceiver to switch from transmit to the receive mode.

4.9.2 Test hook-up (See Fig. 4-9)

4.9.2.1 With all power switches in the OFF position and the transceiver in the receive mode, connect the following:

<u>Connection</u>	<u>Connectors</u>	<u>Cable Type</u>
-------------------	-------------------	-------------------

DUT RF OUTPUT to wattmeter INPUT	As Required to type N	50-Ohm coax
Wattmeter OUTPUT to Power Attn INPUT	Type N to type N	50-Ohm coax
Power Attn OUT to 10-dB step INPUT	Type N to BNC	50-Ohm coax
10-dB step Attn OUT to 1-dB step IN	BNC to BNC	50-Ohm coax
-----		
1-dB step Attn IN to Signal Gen RF OUT	BNC to Type N	50-Ohm coax
DUT Audio OUT to Scope CH2 INPUT	As Required	10X or 1X Probe
-----		
Key Gen Scope OUT to Scope EXT TRIG IN	BNC to BNC	50-Ohm coax
Key Test Gen Key OUT to PTT Key IN	BNC to As Req	50-Ohm coax
XMTR PTT Line to Scope CH1 INPUT	Probe clip to BNC	10X Probe
<u>Connection</u>	<u>Connectors</u>	<u>Cable Type</u>
Two-Tone Gen OUT to DUT MIC INPUT	Banana to As Required	Coax
Power to DUT	As Required	As Required
Scope GND to XMTR GND	As Required	As Required

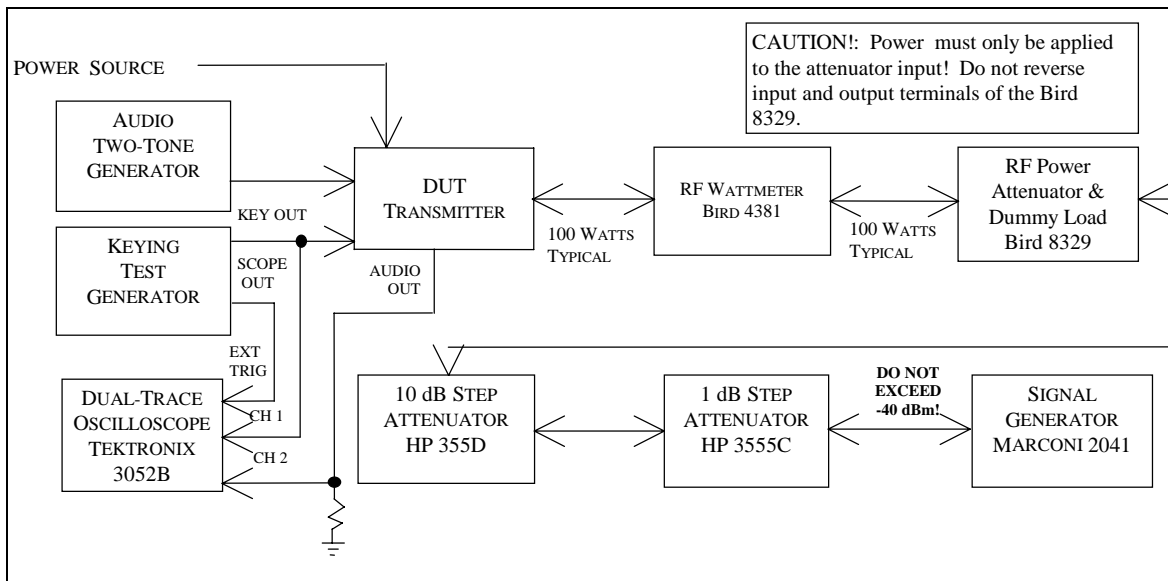

Fig. 4-9 — Transmit/Receive Turnaround Time Test Hook-up

### 4.9.3 Test procedure

4.9.3.1 Turn the DUT, RF wattmeter and oscilloscope power switches to ON. Set the following controls:

<u>Instrument</u>	<u>Control</u>	<u>Position</u>
DUT	Mode	USB
	Frequency	14.250 MHz
	XMIT/RCV	Receive
	AGC	ON (Fastest available)

	Squelch	OFF
RF Wattmeter	Push-button Mode Select Element Forward Element Range	FWD PEP As Required As Required
10-dB Step Attn	Attenuator	120 dB
1-dB Step Attn	Attenuator	0 dB
Keying Test Generator	OUTPUT EN RANGE KEY DOWN KEY UP	OFF 1-99 ms 50 ms 50 ms
Oscilloscope	CH1 VOLTS/DIV CH1 Coupling CH2 VOLTS/DIV CH2 Coupling TIME/DIV Trigger Coupling Trigger Source	0.5 V DC 1 V DC 5 ms DC EXT
Two-Tone Generator	TONE A TONE B HI-Z/LO-Z BALANCE LEVEL ATTENUATOR	ON OFF As Required N/A FULL CCW -30 dB
RF Generator	FREQUENCY TUNE OUT LEVEL RF AM FM	14.250 MHz +10 dBm ON OFF OFF

4.9.3.2 (If proceeding from the previous PTT To SSB RF Output Time Test, this paragraph may be skipped). Set the Two-Tone and Keying Test Generator power switches to ON. Receiver hiss should be heard; adjust the volume to the desired level. Allow all equipment at least 10 minutes warm-up time before proceeding to step 4.9.3.3.

*CAUTION: Reverse power to the RF signal generator at no time should exceed -40 dBm (approx. 2 mV<sub>RMS</sub>). Shut-down of the instrument may result.*

4.9.3.3 Reduce the step attenuators until the signal is heard and a deflection can be observed on the S meter. Tune the receiver for maximum S meter indication. Reduce the RF step attenuators until the receiver S meter indicates an S9 signal. If the DUT does not have an S Meter, then set for a 50 µV input to the DUT.

4.9.3.4 Tune the transmitter, if necessary, exactly per the operator's manual for the 14.250 MHz test frequency. Turn on the two-tone generator and set the A tone switch to ON. With the DUT in the USB mode, set the generator LEVEL and ATTENUATOR controls for the maximum audio input level as specified by the DUT manufacturer. Unkey the transmitter and turn

the keying test generator 4.9.3.5 Key the transmitter and set for the maximum power as ON. Adjust the oscilloscope settings (including sweep rate) as required for an optimum display trace as shown in Fig. 4-9A. If the audio output is not visible at all on the oscilloscope it will be necessary to increase the keying test generator KEY-UP and KEY-DOWN time. Measure and record the time it takes to go from PTT key-up to 50% audio output. Set the keying test generator to OFF.

4.9.3.6 Repeat step 4.9.3.5 for other AGC options, if available, and a 20 dB decrease in signal strength. Check the appropriate box in 4.9.3.6 of the data sheet if no significant deviation is observed. Record the space provided any significant deviation.

4.9.3.7 AMTOR requires the transceiver audio to reach 50% of its full value in 35 ms or less. Determine the AMTOR suitability and record on the data sheet.

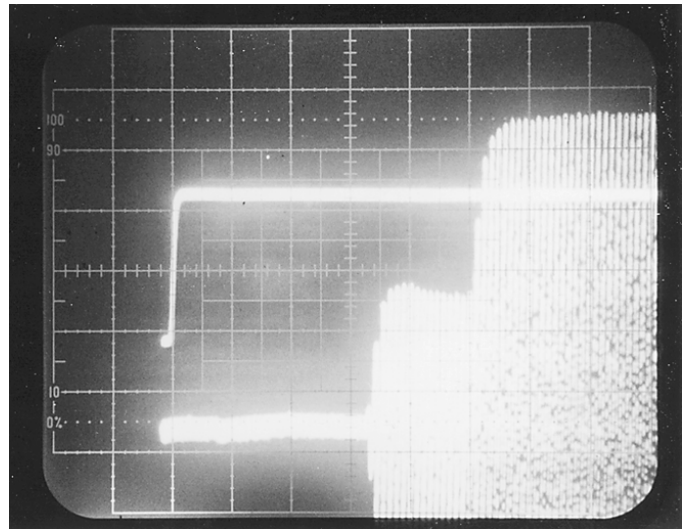

Fig. 4-9A — Oscilloscope Trace of RF Envelope

#### 4.10 KEYER SPEED AND SIDETONE FREQUENCY TEST (For units having an internal keyer.)

4.10.1 The purpose of this test is to measure the transmitter's internal keyer speed range and sidetone frequency range.

4.10.2 Test hook-up (See Fig. 4-10)

4.10.2.1 With all power switches in the OFF position and the transceiver in the receive mode, connect the following:

<u>Connection</u>	<u>Connectors</u>	<u>Cable Type</u>
DUT RF OUTPUT to wattmeter INPUT	As Required to type N	50-Ohm coax
Wattmeter OUTPUT to Power Attn INPUT	Type N to type N	50-Ohm coax
Power Attn OUT to Scope CH1 INPUT	BNC to Type N	50-Ohm coax
DUT Audio OUT to Scope CH2 INPUT	As Required	50-Ohm coax
DUT Audio OUT to 10 dB step Attn IN (10W or greater power rating)	As Required to BNC	50-Ohm coax
10 dB step Attn OUT to Freq Counter IN	BNC to BNC	50-Ohm coax
DUT Audio OUT to HI-Z Amp / 8 Ohm load	As Required to BNC	50-Ohm coax
XMTR Key Input to Telegraph Key	As Required to Test Clips	Any
Power to DUT	As Required	As Required

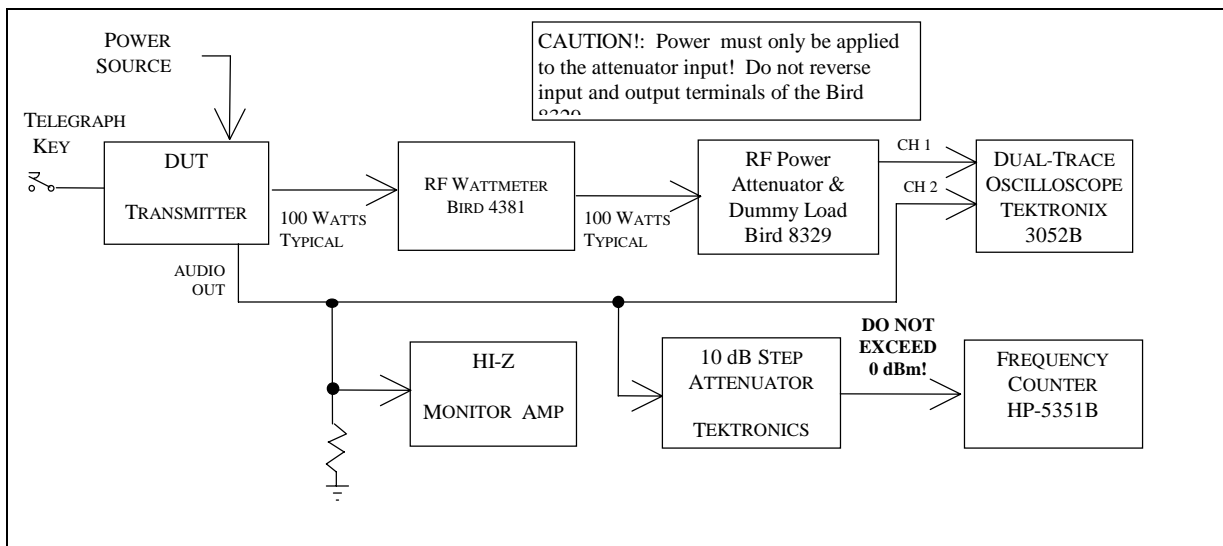

Fig. 4-10 — Keyer Speed and Sidetone Frequency Test Hook-up

### 4.10.3 Test procedure

4.10.3.1 Turn the DUT, RF wattmeter and oscilloscope power switches to ON. Set the following controls:

<u>Instrument</u>	<u>Control</u>	<u>Position</u>
DUT	Mode	USB
	Frequency	14.250 MHz
	XMIT/RCV	Receive
	AGC	N/A
	Squelch	OFF
RF Wattmeter	Push-button Mode Select	FWD PEP
	Element	As Required
	Forward Element Range	As Required
10-dB Step Attn	Attenuator	-40 dB
1-dB Step Attn	Attenuator	0 dB
Oscilloscope	CH1 VOLTS/DIV	0.5 V
	CH1 Coupling	DC
	CH1 Position	As Needed
	CH2 VOLTS/DIV	1 V
	CH2 Coupling	DC
	CH2 Position	As Needed
	TIME/DIV	5 ms
	Trigger Coupling	DC
	Trigger Source	CH1
Trigger Level	As Required	

4.10.3.2 (If proceeding from the previous Turnaround Time Test, this paragraph may be skipped). Receiver hiss should be heard; adjust the volume to the desired level. Allow all equipment at least 10 minutes warm-up time before proceeding to step 4.10.3.3.

4.10.3.3 Key the transmitter. Set the sidetone level for comfortable listening level. Adjust the step attenuators and oscilloscope controls for optimum display. Send a series of dits and then a series of dashes. Verify the dashes are three times longer in duration than the dits. Measure and record any significant deviation from the standard 3 to 1 ratio.

4.10.3.4 With keyer speed still set to minimum, send a series of dits and take a trace in the storage mode. Measure the time duration from the leading edge of a dit to the leading edge of the next. This duration is equivalent to two dits (one dit plus a dit space). Adjust the oscilloscope controls as required to obtain an optimum trace. Divide the measured time by (in ms) into 2400 to obtain the equivalent code speed (in WPM):

Code Speed in WPM = 1200 / Duration of Single Dit in ms      Record on Data Sheet.

4.10.3.5 Set keyer speed to maximum and repeat step 4.10.3.4.

4.10.3.6 Set keyer speed to center or the default position and repeat step 4.10.3.4.

4.10.3.7 Adjust the Frequency Counter Step Attenuators for minimum positive indication. Measure the initial default sidetone frequency . Reduce the sidetone for minimum frequency and measure again. Increase to maximum sidetone frequency and repeat. Record both all three frequencies on Data Sheet.

#### 4.11 COMPOSITE NOISE TEST

4.11.1 The purpose of the Composite-Noise Test is to observe and measure the phase and amplitude noise, as well as any spurious signals generated by the DUT transmitter. Since phase noise is the primary noise component in any well-designed transmitter, it can be assumed, therefore, that almost all the noise observed during this test is phase noise.

4.11.1.1 This measurement is accomplished with the use of an integrated HP model 11848A phase noise test set that consists of a control box (phase discriminator, phase shift network, DC tuning voltage control, and analyzer outputs), HP 3561A FFT-based dynamic signal analyzer, HP 3563E (or 3562A) microwave spectrum analyzer, and as needed, an oscilloscope (for assistance in establishing zero beat). Measurements are accomplished by computer software run on the 486 computer. Additionally, an appropriate low-noise reference oscillator that can be tuned via DC is also necessary.

4.11.2 Test Hook-up (See Fig. 4-11).

4.11.2.1 With all power switches in the OFF position and the transceiver in the receive mode, connect the following:

<u>Connection</u>	<u>Connectors</u>	<u>Cable Type*</u>
DUT RF OUTPUT to wattmeter INPUT	As Required to type N	50-Ohm coax
Wattmeter OUTPUT to Power Attn INPUT	Type N to type N	50-Ohm coax
Power Attn OUT to 10-dB step INPUT	Type N to BNC	50-Ohm coax
10-dB step Attn OUT to 1-dB step IN	BNC to BNC	50-Ohm coax
1-dB step Attn OUT to HP-11848A to "Right" Phase Detector IN	BNC to BNC	50-Ohm coax
Ref. Oscillator OUT to HP-11848A "Left" Phase Detector IN	BNC to BNC	50-Ohm coax
HP-11848A Tuning voltage to Test	BNC to BNC or clip leads	As Required
HP-11848A Phase Detector Output to HP-3561A FFT Signal Analyzer	BNC to BNC	50-Ohm coax

HP-11848 Spectrum Analyzer OUT to HP-8563 E Spectrum Analyzer	BNC to BNC	50-Ohm coax
Power to DUT	As Required	As Required
HP-11848A Aux Monitor OUT to TDS-3052B Oscilloscope CH 1 IN	BNC to BNC	50-Ohm coax

\*NOTE: Composite noise setup is very sensitive to environment noise. Use of common-mode ferrite chokes may be required if test fixture problems are encountered as described in the procedure for this test.

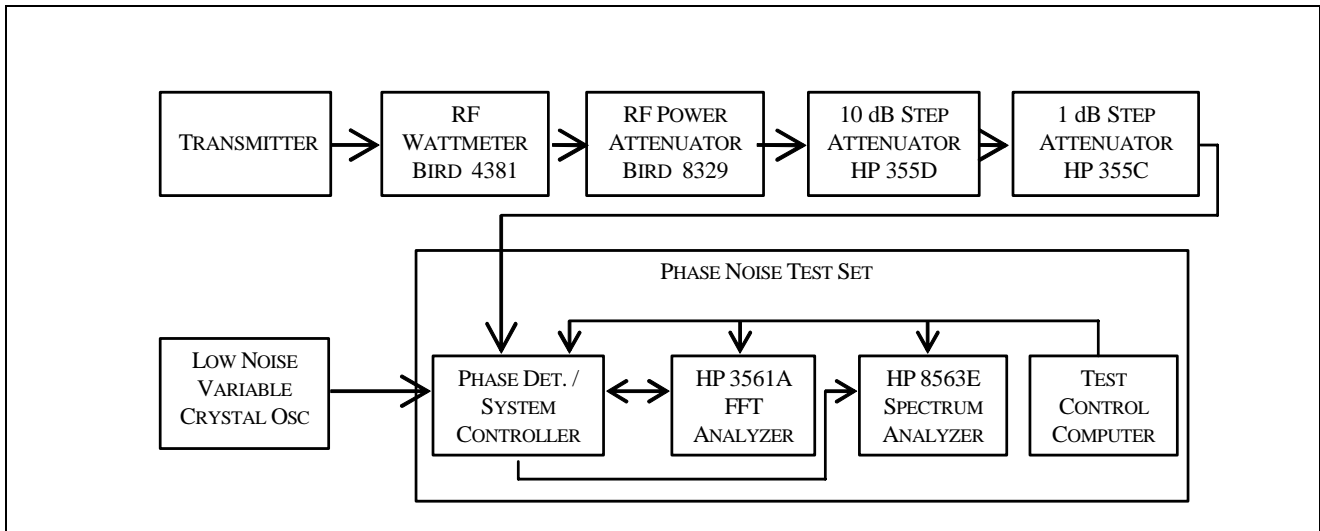

Fig. 4-11 — Composite Noise Test Hook-up

### 4.11.3 Test procedure

4.11.3.1 Turn the DUT, RF wattmeter, test system, spectrum analyzer power, and reference oscillator switches to ON. Set the following controls:

<u>Instrument</u>	<u>Control</u>	<u>Position</u>
DUT	Mode Band Selector Frequency Output Power	CW 20 Meters 14.025 MHz 30-50 %
RF Wattmeter	Push-button Mode Select Element Forward Element Range	FWD CW As Required As Required
10-dB Step Attn 1-dB Step Attn	Attenuator Attenuator	As required for +15 dBm Any
Reference Oscillator	FREQUENCY	14.025 MHz

4.11.3.2 Allow all equipment, including the test oscillator, at least 15 minutes warm-up time before proceeding. TURN OFF all non essential test equipment and overhead fluorescent lights. Use the incandescent lighting.

4.11.3.3 Check the manufacturer's specification of the transmitting duty cycle. If not stated, set the power output to 30 watts for a 100 watt maximum transmitter, or 50 watts for a 200 watt maximum transmitter. The test will take about 15 minutes; do not exceed manufacturer's duty cycle

4.11.3.4 Turn on the control computer, allow it to complete the boot and program start processes, then step through the menu system to set the initial test frequency and VFO tune ranges. On the menu, the test frequency has a scientific format; example: 14.025E+6 (14.025 x 10 to the 6<sup>th</sup> power). For the Wenzel crystal oscillators, use 14.025 MHz, a VCO tune center voltage of approximately 5 and a tune voltage range of +/-5 V. For the Marconi/IFR 1041 signal generators, set the tune center voltage to 0 and a tuning range +/-5V. All other parameters should be ok at their initial values.

4.11.3.5 Key the transmitter and adjust the frequency of the DUT to be approximately 1 Hz or less from the frequency of the reference oscillator. Use an oscilloscope, if necessary, to remove any undulating shape on the screen of the noise output. The two frequencies must not be equal or a phenomenon known as phase roll may result, and, if much greater than 2 Hz apart, the software will not run and will show an error message. The tuning voltage of the test oscillator may be adjusted slightly in the software if the transmitter tuning cannot be brought less than 1 Hz. The idea is to get as close as possible, without being identical. The signal should be unreadable and only the noise clearly visible on the analyzer display before proceeding to the next step. Un-key the transmitter.

4.11.3.6 To measure the Phase Noise, key the transmitter and run the program. After about three minutes, you should see a graph of the composite noise forming on the PC screen. After 15 minutes or so, the process will be complete and the file is saved as a type .PCX file. Before saving the file, press "M" and omit the spurs (red lines on the graph). Copy the file to disc.

4.11.3.7 Repeat steps 4.11.3.4 through 4.11.3.6 with a test frequency of 50.020 MHz. With this test, you will replace the Test Oscillator with the IFR 2041 Signal Generator in the "Low Noise" mode. Set the following controls on the IFR2041:

External 1 to "DC Coupling"  
Deviation to 3 kHz, MODULATION ENABLED  
RF Level to +13 dBm  
Frequency to 50.020  
RF Output to "Left" Phase Detector Input  
External 1 to Tune Voltage Output

Be sure to change the following on the software menu:

Frequency to 50.020E+6  
Detector Frequency is + 6 volts  
Center Tune Volts is 0.0 volts  
Tune Range is 6 volts.

Near zero beat using the scope and run the program. Save file to disc.

## V. RECEIVER TESTS

5.0.1 As shown in the Table of Contents, there are 17 Receiver tests outlined in this chapter. They have been arranged, just as in the previous transmitter tests, to minimize the required level and frequency of hook-up changes and modifications. Each hook-up, however, is shown complete with all changes from the previous test clearly indicated.

A block diagram accompanies each hook-up and any changes from the previous test are shown within a dotted rectangle. This affords the flexibility to easily start anywhere and perform these tests in any desired order.

5.0.2 Before performing any receiver testing, it is essential for the test engineer to be completely familiar with the Device Under Test (DUT) and the test equipment that will be used. The RF output of a transceiver will damage the test equipment and therefore, *it is essential never to accidentally key the transmitter while performing these tests!* Completely disable the transmitter if at all possible and set all RF output controls to minimum, reduce drive, disconnect the telegraph key, etc. The receiver must be operated in a manner exactly as specified by the manufacturer. Any test that would cause equipment to be operated in a manner inconsistent with its operating manual must be modified accordingly.

5.0.2.1 Other considerations are as follows:

- 1) The RF Generator output must not exceed  $-14$  dBm when using the Hybrid Combiner. This restriction is an effort to minimize intermodulation in the combiner and signal generators.
- 2) The level of input to the receiver should not exceed  $+10$  dBm or the manufacturer's specification, whichever is less.
- 3) Read and understand all pertinent manuals before operating any laboratory instrument or the DUT receiver.
- 4) The testing should be conducted in a relatively RF free environment. If an RF source is in close proximity to the testing site, an RF screen room should be used.
- 5) If a preamp is available, each test must be performed with each level of the preamp and without the preamp.
- 6) If the audio output impedance is not 8 Ohms, select the appropriate load resistance on the HI-Z Audio Amplifier.

## 5.1 NOISE FLOOR TEST

5.1.1 The purpose of the Noise Floor Test (also known as “Minimum Discernible Signal” or MDS) is to determine the level of signal input to the receiver that will produce an audio output where the power in the signal is equal to the power in the noise ( $S + N = N + 3$  dB). The test is conducted with the receiver in the CW mode using the 500 Hz, or closest available IF filter (or audio filters where IF filters are not available. For receivers that have appropriate IF

filters, all audio filtering is disabled.) Set the AGC to the OFF position if possible. The test is performed frequencies of 1.020 MHz, 3.520 MHz, 14.020 MHz, 50.020 MHz, 144.020 MHz and 432.020 MHz. For the expanded set of tests, this test is performed on all available amateur bands, 20 kHz above the lower band edge.

5.1.2 Test hook-up (See Fig. 5-1)

5.1.2.1 With all power switches in the OFF position, the transmitter function disabled to the fullest extent possible and the Generator RF switch OFF, connect the following:

<u>Connection</u>	<u>Connectors</u>	<u>Cable Type</u>
Signal Gen OUTPUT to 10-dB Step Attn INPUT	BNC to BNC	50-Ohm Coax
10-dB Step Attn OUTPUT to DUT RF INPUT	BNC to As Required	50-Ohm Coax
DUT AUDIO OUT to Dist/Audio Meter IN	As Required to BNC	50-Ohm Coax
8-Ohm Load/HI-Z Amp Across Dist/Audio Meter Input	As Required	As Required
Power Source to DUT Power Input	As Required	As Required

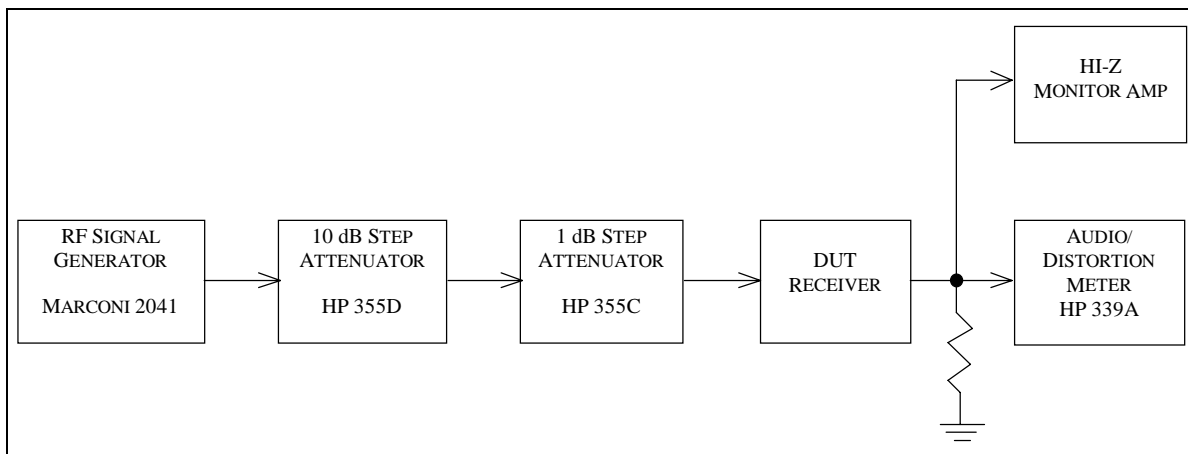

Figure 5-1 -- CW MDS Test Hook-up

### 5.1.3 Test Procedure

5.1.3.1 Turn the DUT and all test equipment power switches to ON. If the DUT does not cover 1.020 MHz, proceed directly to the second test frequency of 3.520 MHz. Set the following controls:

<u>Instrument</u>	<u>Control</u>	<u>Position</u>
DUT	Mode	CW
	Band Selector	As Required for 1.020 MHz
	Frequency	1.020 MHz
	XMIT/RCV	RCV
	DRIVE or RF LEVEL	Minimum
	IF Filters	500 Hz or Closest Available
	AGC	OFF
	Preamplifier	OFF
10 dB Step Attn	Attenuator	0 dB
RF Generator	CARRIER FREQ	1.020 MHz
	RF LEVEL	-110 dBm
	NOISE MODE (UTIL)	LOW NOISE
Audio/Distortion Meter	FUNCTION	REL LEVEL
	RELATIVE ADJUST	Center Rotation
	FILTERS	All Off (Out)
	INPUT RANGE	30 V
	INPUT/GND SELECT	DIS (Center)
	METER RESPONSE	NORM

5.1.3.2 Receiver hiss should be heard. Adjust the volume of the DUT and HI-Z monitor amp to the desired level. Allow all equipment at least 10 minutes warm-up time before proceeding to step 5.1.3.3.

5.1.3.3 Verify the RF Generator Output frequency has remained at 1.020 MHz. Reset if necessary.

5.1.3.4 Tune the receiver for 1.020 MHz. Adjust the INPUT RANGE and RELATIVE ADJUST controls as required to maintain approximately a mid-scale meter indication while carefully tuning the receiver for peak signal response. (Rotate the Generator OUTPUT LEVEL control as required until the signal is just heard in the receiver.)

5.1.3.5 Set the RF Generator RF switch to OFF. Decrease the Audio Meter INPUT RANGE until the meter indication is near mid-scale and the two lights above this control are out. Adjust the audio meter RELATIVE ADJUST control until the audio meter reads -6 dB on the upper scale. (Adjust the INPUT RANGE control one step in either direction if necessary.)

5.1.3.6 Set the RF Generator RF switch to ON. Rotate the generator OUTPUT LEVEL control to produce an audio meter reading of -3 dB. Ensure that the DUT is tuned for peak response.

5.1.3.7 Check to ensure that the Generator frequency is still at 1.020 MHz. Set the RF Generator RF to OFF. The audio meter should return to -6 dB. Turn the RF back on and the meter should again indicate -3 dB.

5.1.3.8 Determine the noise floor (MDS) of the receiver by computing the sum of the RF generator output in dBm and the 10 dB step attenuator. (NOTE: Be sure to include any additional attenuation you may have included in the line between the generator and the DUT.) Record on the Data Sheet.

- Example: a) The RF generator is set for  $-128.6$  dBm output.  
 b) The step attenuators are set for  $-10$  dB.  
 c) The receiver MDS, therefore, is:

$$-128.6 - 10 = -138.6 \text{ dBm}$$

5.1.3.9 Repeat steps 5.1.3.4 to 5.1.3.8 with DUT preamplifier set to ON.

5.1.3.10 Reset the generator output level to  $-110$  dBm. Repeat paragraphs 5.1.3.3 to 5.1.3.9 for a test frequency of 3.520 MHz.

5.1.3.11 Repeat step 5.1.3.10 for a test frequency of 14.020 MHz.

5.1.3.12 Repeat step 5.1.3.10 for test frequencies of 50.020 MHz, 144.020 MHz and 432.020 MHz, as applicable to the DUT.

5.1.3.13 For an expanded set of tests, repeat step 5.1.3.10 for all remaining amateur bands.

## 5.2 AM RECEIVE SENSITIVITY TEST

5.2.1 The purpose of the AM receive Sensitivity Test is to determine the level of an AM signal, 30% modulated at 1 kHz, that will produce a tone 10 dB above the noise level (MDS) of the DUT. Two frequencies, 1.020 MHz and 3.800 MHz are used for this test.

5.2.2 Test hook-up (See Fig. 5-2)

**NOTE:** If proceeding from the MDS Test, no hook-up changes are required. Proceed to step 5.2.3.

5.2.2.1 With all power switches in the OFF position and the transmitter function disabled to the fullest extent possible, connect the following:

<u>Connection</u>	<u>Connectors</u>	<u>Cable Type</u>
Signal Gen OUTPUT to 10-dB Step Attn INPUT	BNC to BNC	50-Ohm Coax
10-dB Step Attn OUTPUT to DUT RF INPUT	BNC to As Required	50-Ohm Coax
DUT Audio OUTPUT to Dist/Audio Meter INPUT	As Required to BNC	50-Ohm Coax
8 Ohm Load/HI-Z Amp Across Dist/Audio Meter INPUT	As Required	As Required
Power Source to DUT Power Input	As Required	As Required

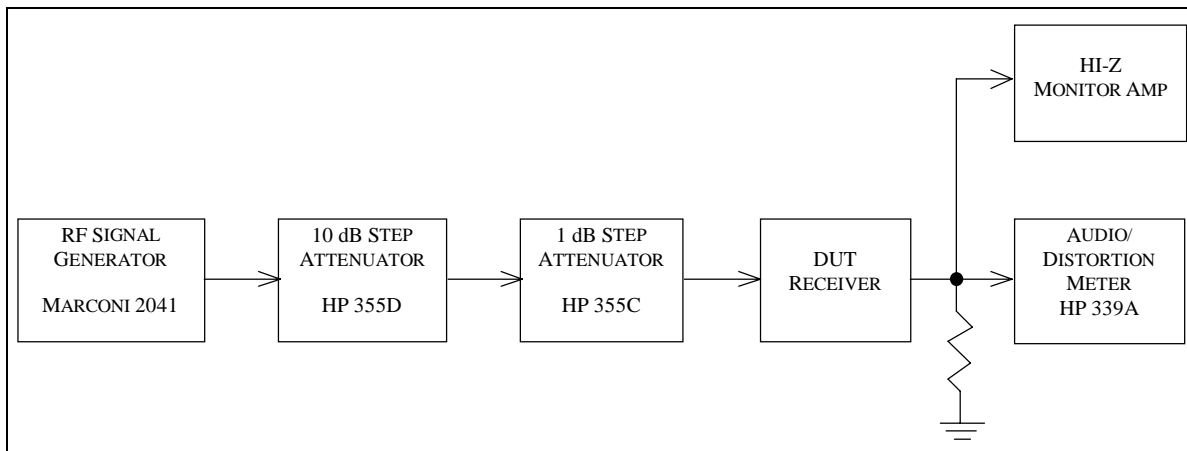

Fig. 5-2. AM Receive Sensitivity Test Hook-Up

### 5.2.3 Test Procedure

5.2.3.1 Turn the DUT and all test equipment power switches to ON. If the DUT does not cover 1.020 MHz, proceed directly to the second test frequency of 3.800 MHz. Set the following controls:

<u>Instrument</u>	<u>Control</u>	<u>Position</u>
DUT	Mode	AM
	Band Selector	As Required for 1.020 MHz
	Frequency	1.020 MHz
	XMIT/RCV	RCV
	DRIVE or RF LEVEL	Minimum
	IF Filters	AM (Approx. 6 kHz)
	AGC	OFF
	Preamplifier	OFF
	DUT Audio Filter(s)	Disabled
10-dB Step Attn	Attenuator	0 dB
	RF Generator	
	CARRIER FREQ	1.020 MHz
	RF LEVEL	-110 dBm
	CARR ON-OFF	ON
	AM	ON
	AM DEPTH	30%
	Modulation Frequency	1000 Hz
	FM	OFF
	NOISE MODE	LOW NOISE MODE
Audio/Distortion Meter	FUNCTION	REL. LEVEL
	RELATIVE ADJUST	Center Rotation
	FILTERS	All OFF (Out)
	INPUT RANGE	30 V
	INPUT/GND SELECT	DIS (Center)
	METER RESPONSE	NORM

5.2.3.2 Receiver hiss should be heard. Adjust the DUT and HI-Z monitor amp volume to the desired level. Allow all equipment at least 10 minutes warm-up time before proceeding to step 5.2.3.3.

5.2.3.3 Tune the receiver for 1.020 MHz. Adjust the Audio Meter INPUT RANGE control as required to maintain approximately a mid-scale meter indication while carefully tuning the receiver for peak signal response. (If necessary, adjust the Generator OUTPUT LEVEL as required until the signal is just heard in the receiver.)

5.2.3.4 Set the RF Generator modulation control switch to OFF. Decrease the Audio Meter INPUT RANGE until the meter indication is near mid-scale and the two lights above this control are out. Adjust the audio meter RELATIVE ADJUST control until the audio meter reads -11 dB on the upper scale. (Adjust the INPUT RANGE control one step in either direction if necessary.)

5.2.3.5 Set the RF Generator RF switch to ON. Adjust the setting of the generator RF OUTPUT LEVEL to produce an audio meter reading of -1 dB +/- .5 dB. Recheck for peak response using the audio meter.

5.2.3.6 Check to ensure that the Generator frequency is still at 1.020 MHz. Set the RF Generator modulation to OFF. The audio meter should return to -11 dB. Turn the modulation back on and the meter should again indicate -1 dB.

**NOTE: The following measurement method is often better**, especially in cases where the DUT AGC cannot be disabled. The Audio Meter settings are the same as for the FM SINAD Test except the DISTORTION RANGE is set for 0-100% distortion. Adjust the signal generator output level for the following equivalent distortion level as required:

$$10 \text{ dB } (S+N)/N = 31.6\%$$

5.2.3.7 Determine the AM 10 dB sensitivity of the receiver by computing the sum of the output level of the RF generator, as read from the OUTPUT LEVEL switch and meter, and any additional attenuation in the line between the generator and the DUT. Record on the Data Sheet.

Example: a) The RF generator is set for -113 dBm output.  
b) The step attenuators are set for 10 dB.  
c) The receiver AM sensitivity is:  
-113 - 10 = -123 dBm

5.2.3.8 Set the DUT preamplifier to ON and repeat steps 5.2.3.3 to 5.2.3.7.

5.2.3.9 Return the RF generator OUTPUT LEVEL control to -110 dBm and set for 3.800 MHz. Repeat paragraphs 5.2.3.3 to 5.2.3.8 for this test frequency.

### 5.3 FM SINAD AND QUIETING TEST

5.3.1 The purpose of the FM SINAD and Quieting Test is to determine the 12 dB SINAD value. SINAD is an acronym for "Signal plus Noise And Distortion" and is a measure of signal quality. The exact expression for SINAD is:

$$\text{SINAD} = \frac{\text{Signal} + \text{Noise} + \text{Distortion}}{\text{Noise} + \text{Distortion}} \quad (\text{expressed in dB})$$

If we consider distortion to be merely another form of noise, (distortion, like noise, is something unwanted added to the signal), we can further reduce the equation for SINAD to:

$$\text{SINAD} = \frac{\text{Signal} + \text{Noise}}{\text{Noise}} \quad (\text{expressed in dB})$$

If we now consider a practical circuit in which the signal is much greater than the noise, the value of the SIGNAL + NOISE can be approximated by the level of the SIGNAL alone. The SINAD equation then becomes the signal to noise ratio and can be approximated by:

$$\text{SINAD} = \frac{\text{Signal (expressed in dB)}}{\text{Noise}}$$

For 25% level of distortion, SINAD can be calculated as:  $\text{SINAD} = 20 \log (1/25\%) = 20 \log 4 = 12 \text{ dB}$

### 5.3.2 Test hook-up (See Fig. 5-3)

**NOTE:** If proceeding from the previous AM Receive Sensitivity Test, no hook-up changes are required. Proceed directly to step 5.3.3.

5.3.2.1 With all power switches in the OFF position and the transmitter function disabled to the fullest extent possible, connect the following:

<u>Connection</u>	<u>Connectors</u>	<u>Cable Type</u>
Signal Gen OUTPUT to 10-dB Step Atten INPUT	BNC to BNC	50-Ohm Coax
10-dB Step Attn OUTPUT to DUT RF INPUT	BNC to As Required	50-Ohm Coax
DUT AUDIO OUTPUT to Dist/Audio Meter IN	As Required to BNC	50-Ohm Coax
8 Ohm Load/Hi-Z Amp Across Dist/Audio Meter INPUT	As Required	As Required
Power Source to DUT Power Input	As Required	As Required

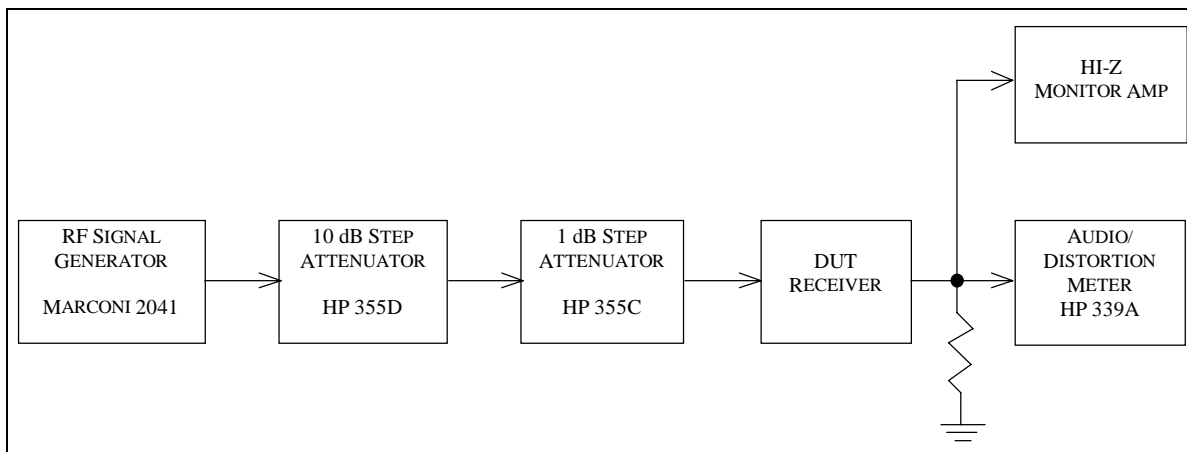

Fig. 5-3 FM SINAD and Quieting Test Hook-Up

### 5.3.3 Test Procedure

5.3.3.1 Turn the DUT and all test equipment power switches to ON. Set the following controls:

<u>Instrument</u>	<u>Control</u>	<u>Position</u>
DUT	Mode	FM
	Frequency	29.000 MHz
	XMIT/RCV	RCV
	DRIVE or RF LEVEL	Minimum
	RF Gain	Maximum
	IF Filters	FM (Aprx.15 kHz)
	AGC	OFF
	Preamplifier	OFF
10-dB Step Attn	Attenuator	0 dB
RF Generator	CARRIER FREQUENCY	29.000 MHz
	RF LEVEL	-110 dBm
	CARR ON-OFF	ON
	NOISE MODE	NORMAL <sup>1</sup>
	FM	On
	AM	Off
	FM DEVN	3 kHz
Modulation Frequency	1000 HZ	
Audio/Distortion Meter	FUNCTION	DISTORTION
	RELATIVE ADJUST	Any
	METER	-10/30
	FREQUENCY CONTROLS	1.0 X 1 kHz
	FILTERS	Low Pass On
	INPUT RANGE	30 V
	INPUT/GND SELECT	DIS (Center)
METER RESPONSE	NORM	

5.3.3.2 Receiver hiss should be heard. Adjust the volume to the desired level. Allow all equipment at least 10 minutes warm-up time before proceeding to step 5.3.3.3.

5.3.3.3 Turn the DUT's preamp on and tune the receiver for 29.000 MHz. Rotate the Generator OUTPUT LEVEL control as required until the signal is just heard in the receiver. Set the DUT volume control for a normal listening level, and carefully tune the receiver for minimum distortion. (This control should be set roughly between 1/4 and 3/4 of the maximum limit.)

5.3.3.4 Gradually increase the Signal Generator output until the Distortion Meter indicates 25% distortion. (The step Attenuator may also be used, if necessary, to help achieve the reading.)

5.3.3.5 Measure the level of the input signal to the DUT receiver and record in 5.3.3.5 of the Data sheet. Be sure to account for any attenuation in the line from the step attenuators or hybrid combiner.

- Example: a) The RF generator is set for -112.4 dBm output  
 b) The step attenuator is set for 10 dB  
 c) The FM SINAD is:

$$\underline{-112.4 - 10 = -122.4 \text{ dBm}}$$

5.3.3.6 Repeat steps 5.3.3.3 to 5.3.3.5 with the DUT preamp off.

5.3.3.7 Reduce the Generator Output to -110 dBm. Repeat paragraphs 5.3.3.4 and 5.3.3.5 for any other applicable FM filters.

**NOTE:** The following tests are only performed if quieting is specified by the manufacturer. Repeat these tests for all applicable bandwidths and preamp settings.

#### *10 dB Quieting*

5.3.3.8 Reduce the Generator Output to -110 dBm and reset the step attenuators if necessary to 0 dB. Set the Audio/Distortion meter to REL LEVEL and the RF Generator FM modulation button to OFF.

5.3.3.9 Set the Generator RF button to OFF. Adjust the INPUT RANGE and the RELATIVE ADJUST controls for a reading of -3 dB on the audio meter. Rotate the INPUT RANGE control 1 detent CCW. Gradually increase the output of the RF generator until the audio meter again indicates -3 dB (or a 10 dB decrease). The step attenuators may be used as necessary to help achieve this reading.

5.3.3.10 Set the RF button to OFF and the INPUT RANGE control 1 detent CW. The meter should return to -3 dB. Return the RF switch to ON and rotate the INPUT RANGE control 1 detent CCW. The meter should again indicate -3 dB. Record the input level to the DUT in 5.3.3.10 of the Data Sheet.

#### *20 dB Quieting*

5.3.3.11 Set the RF button to OFF. Adjust the INPUT RANGE and the RELATIVE ADJUST controls for a reading of -3 dB on the audio meter. Rotate the INPUT RANGE control 2 detents CCW. Gradually increase the output of the RF generator until the audio meter again indicates -3 dB (or a 20 dB decrease). The step attenuators may be used as necessary to help achieve this reading.

5.3.3.12 Set the RF button to OFF and the INPUT RANGE control 2 detent positions CW. The meter should return to -3 dB. Return the RF button to ON and rotate the INPUT RANGE control 2 detent positions CCW. The meter should again indicate -3 dB. Record the input level to the DUT in 5.3.3.12 of the Data Sheet.

5.3.3.13 Repeat paragraphs 5.3.3.3 to 5.3.3.7 for the following frequencies, as applicable to the DUT:

## **5.4 RECEIVE FREQUENCY RANGE TEST**

5.4.1 The purpose of the Receive Frequency Range Test determine both the practical receive frequency range as well as the absolute maximum frequency range limits.

5.4.2 Test hook-up (See Fig. 5-4)

5.4.2.1 With all power switches in the OFF position, the transmitter function disabled to the fullest extent possible and the Generator RF switch OFF, connect the following:

<u>Connection</u>	<u>Connectors</u>	<u>Cable Type</u>
Signal Gen OUTPUT to 10-dB Step Attn INPUT	BNC to BNC	50-Ohm Coax
10-dB Step Attn OUTPUT to DUT RF INPUT	BNC to As Required	50-Ohm Coax
DUT Audio Output to Dist/Audio Meter Input	As Required to BNC	50-Ohm Coax

<u>Connection</u>	<u>Connectors</u>	<u>Cable Type</u>
-------------------	-------------------	-------------------

8-Ohm Load/Hi-Z Amp to Dist/Audio Meter Input	As Required	As Required
Power Source to DUT Power Input	As Required	As Required

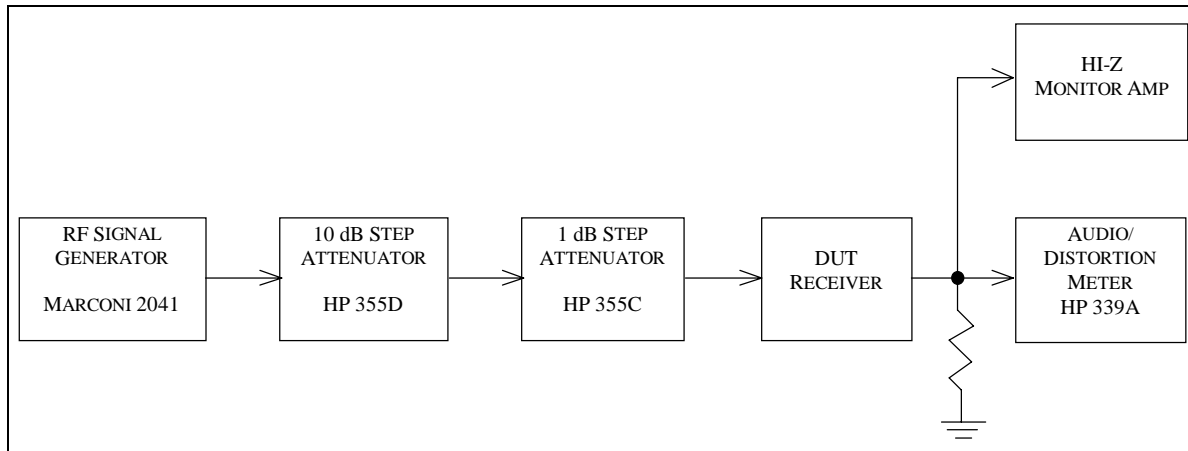

Fig. 5-4 — Receive Frequency Range Test Hook-up

### 5.4.3 Test Procedure

5.4.3.1 Turn the DUT and all test equipment power switches to ON. Set the following controls:

<u>Instrument</u>	<u>Control</u>	<u>Position</u>
DUT	Mode	CW
	Band Selector	Lowest Available
	Frequency	Lowest Available
	XMIT/RCV	RCV
	DRIVE or RF LEVEL	Minimum
	IF Filters	500 Hz or Closest Available
	AGC	OFF
	Preamplifier	OFF
10 dB Step Attn	Attenuator	10 dB
RF Generator	CARRIER FREQ	Same as DUT
	RF LEVEL	-110 dBm
	CARR ON-OFF	OFF
	AM	Off
	FM	Off
	NOISE MODE	LOW NOISE
Audio/Distortion Meter	FUNCTION	REL LEVEL
	RELATIVE ADJUST	Center Rotation
	FILTERS	All Off (Out)
	INPUT RANGE	30 V
	INPUT/GND SELECT	DIS (Center)
METER RESPONSE	NORM	

5.4.3.2 Receiver hiss should be heard. Adjust the volume of the DUT and HI-Z monitor amp to the desired level. Allow all equipment at least 10 minutes warm-up time before proceeding to step 5.4.3.3.

5.4.3.3 Tune the receiver for the minimum frequency possible. Verify useful sensitivity by performing an MDS test and record results in 5.4.3.2 of the Data Sheet. If useful sensitivity is not achieved, increase frequency and repeat until useful sensitivity is obtained. Perform an MDS test the DUT's specified limit if other than the lowest possible frequency.

NOTE: Useful sensitivity is somewhat ambiguous. In general terms, a receiver with less than about –100 dBm MDS sensitivity is probably marginal. Anything less than that is usually not practical for most applications.

5.4.3.4 Tune the receiver to the minimum frequency possible. Note and record any frequencies not being received by or not included in the tuning range of the DUT.

5.4.3.5 Repeat step 5.4.3.3 for the highest possible frequency. Reduce the as required for useful sensitivity and perform an MDS test at the maximum specified frequency.

**NOTE: For amateur equipment, always check for reception in the cellular bands at 824-849 and 869-894 MHz.**

## 5.5 FIRST IF AND IMAGE REJECTION TEST

5.5.1 The purpose of the first IF and Image Rejection Test is to determine the level of signal input to the receiver at the first IF and Image frequencies that will produce an audio output equal to the MDS level. The test is conducted with the receiver in the CW mode using the 500 Hz, or closest available, IF filters. Any audio filtering is disabled and the AGC is set to the OFF position if possible. The test is performed with the DUT tuned to 14.020 MHz.

5.5.2 Test hook-up (See Fig. 5-5)

5.5.2.1 With all power switches in the OFF position, the transmitter function disabled to the fullest extent possible and the Generator RF switch OFF, connect the following:

<u>Connection</u>	<u>Connectors</u>	<u>Cable Type</u>
Signal Gen OUTPUT to 10-dB Step Attn INPUT	BNC to BNC	50-Ohm Coax
10-dB Step Attn OUTPUT to DUT RF INPUT	BNC to As Required	50-Ohm Coax
DUT AUDIO OUTPUT to Dist/Audio Meter IN	As Required to BNC	50-Ohm Coax
8-Ohm Load/HI-Z Amp Across Dist/Audio Meter Input	As Required	As Required
Power Source to DUT Power Input	As Required	As Required

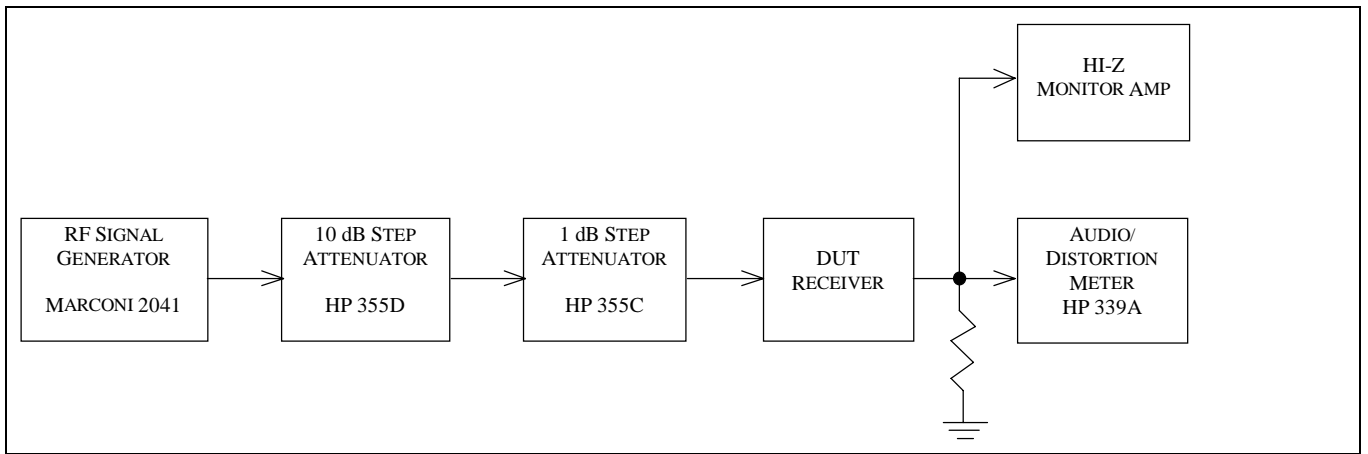

Fig. 5-5 — IF And Image Test Hook-up

### 5.5.3 Test Procedure

5.5.3.1 Turn the DUT and all test equipment power switches to ON. Set the following controls:

<u>Instrument</u>	<u>Control</u>	<u>Position</u>
DUT	Mode	CW
	Band Selector	20 Meters
	Frequency	14.020 MHz
	XMIT/RCV	RCV
	DRIVE or RF LEVEL	Minimum
	IF Filters	500 Hz or Closest Available
	AGC	OFF
	Preamplifier	OFF
10 dB Step Attn	Attenuator	10 dB
	RF Generator	
RF Generator	CARRIER FREQ	DUT 1st IF
	RF LEVEL	-80 dBm
	CARR ON-OFF	ON
	AM	Off
	FM	Off
	NOISE MODE	LOW NOISE
Audio/Distortion Meter	FUNCTION	REL LEVEL
	RELATIVE ADJUST	Center Rotation
	FILTERS	All Off (Out)
	INPUT RANGE	30 V
	INPUT/GND SELECT	DIS (Center)
	METER RESPONSE	NORM

5.5.3.2 Receiver hiss should be heard. Adjust the volume of the DUT and HI-Z monitor amp to the desired level. Allow all equipment at least 10 minutes warm-up time before proceeding to step 5.5.3.3.

5.5.3.3 Verify the RF Generator Output frequency has remained at the DUT 1st IF. Reset if necessary.

5.5.3.4 Tune the receiver for 14.020 MHz. Rotate the Generator OUTPUT LEVEL control as required until the signal is just heard in the receiver. Adjust the INPUT RANGE and RELATIVE ADJUST controls as required to maintain

approximately a midscale meter indication while carefully tuning the Generator CARRIER FREQ control for peak signal response.

5.5.3.5 Set the RF Generator RF switch to OFF. Decrease the Audio Meter INPUT RANGE until the meter indication is near mid-scale and the two lights above this control are out. Adjust the audio meter RELATIVE ADJUST control until the audio meter reads -6 dB on the upper scale. (Adjust the INPUT RANGE control one step in either direction if necessary.)

5.5.3.6 Set the RF Generator RF switch to ON. Rotate the generator OUTPUT LEVEL control to produce an audio meter reading of -3 dB. Ensure that the Generator CARRIER FREQ control is tuned for peak response.

5.5.3.7 Set the RF Generator RF to OFF. The audio meter should return to -6 dB. Turn the RF back on and the meter should again indicate -3 dB.

5.5.3.8 Determine the IF level of the receiver by computing the sum of the RF generator output in dBm and the 10 dB step attenuator. (NOTE: Be sure to include any additional attenuation you may have included in the line between the generator and the DUT.) Find the difference in dB from the 20 Meter MDS (with preamp off) previously measured in the test battery. Record on the Data Sheet.

Example: a) The RF generator is set for -36.1 dBm output.

b) The step attenuators are set for -10 dB.

c) The receiver IF rejection level, therefore, is:

$$-36.1 - 10 = -46.1 \text{ dBm}$$

d) If we measured the noise floor to be -138.6 dBm

in the Noise Floor Test, then the IF rejection is:

$$-46.1 \text{ dBm} - (-138.6 \text{ dBm}) = 92.5 \text{ dB}$$

5.5.3.9 Repeat steps 5.5.3.4 to 5.5.3.8 with DUT preamplifier set to ON.

5.5.3.10 Calculate the first IF image frequency as follows:

$$14.020 \text{ MHz} \pm (2 \times \text{IF in MHz}) = \text{Image Frequency in MHz}$$

Note there are two potential image frequencies if the 1st IF is less than 7.010 MHz Check *BOTH* frequencies for a response and record the appropriate one in 5.5.10 of the Data Sheet.

5.5.3.11 Tune the receiver for 14.020 MHz. Rotate the Generator OUTPUT LEVEL control as required until the signal is just heard in the receiver. Tune the Signal Generator to the other potential image frequency calculated in step 5.5.3.10. Compare the DUT response between the two input frequencies and set the Generator to the frequency that results in the greatest output response. Reduce the generator to provide an approximately the MDS level at the image frequency.

5.5.3.12 Adjust the INPUT RANGE and RELATIVE ADJUST controls as required to maintain approximately a mid-scale meter indication while carefully tuning the Generator CARRIER FREQ control for peak signal response. Increase the generator output level if necessary.

5.5.3.13 Set the RF Generator RF switch to OFF. Decrease the Audio Meter INPUT RANGE until the meter indication is near mid-scale and the two lights above this control are out. Adjust the audio meter RELATIVE ADJUST control until the audio meter reads -6 dB on the upper scale. (Adjust the INPUT RANGE control one step in either direction if necessary.)

5.5.3.14 Set the RF Generator RF switch to ON. Rotate the generator OUTPUT LEVEL control to produce an audio meter reading of -3 dB. Ensure that the Generator CARRIER FREQ control is tuned for peak response.

5.5.3.15 Set the RF Generator RF to OFF. The audio meter should return to -6 dB. Turn the RF back on and the meter should again indicate -3 dB. Record the Signal Generator output in 5.5.3.7 of the data Sheet and calculate the Image Rejection as follows:

- Example:
- a) The RF generator is set for -59.6 dBm output.
  - b) The step attenuators are set for -10 dB.
  - c) The receiver image rejection level, therefore, is:  $-59.6 - 10 = -69.6$  dBm
  - d) If we measured the noise floor to be -138.6 dBm in the previous Noise Floor Test, the image rejection is:  $-69.6$  dBm -  $(-138.6$  dBm) = 69.0 dB

5.5.3.16 Reset the generator output level to -80 dBm. Repeat steps 5.5.3.13 to 5.5.3.15 with the DUT preamplifier set to ON.

## 5.6 ANTENNA PORT ISOLATION TEST (For Receivers with multiple antenna ports only)

5.6.1 The purpose of this test is to determine the level of isolation between antenna ports with receivers having multiple antenna ports. A comparison in MDS sensitivity is made between an unused and used antenna port. The test is conducted with the receiver in the CW mode using the 500 Hz, or closest available, IF filters. Any audio filtering is disabled and the AGC is set to the OFF position if possible. The test is performed with the DUT tuned to 14.020 MHz.

5.6.2 Test hook-up (See Fig. 5-6)

5.6.2.1 With all power switches in the OFF position, the transmitter function disabled to the fullest extent possible and the Generator RF switch OFF, connect the following:

<u>Connection</u>	<u>Connectors</u>	<u>Cable Type</u>
Signal Gen OUTPUT to 10-dB Step Attn INPUT	BNC to BNC	50-Ohm Coax
10-dB Step Attn OUTPUT to DUT RF INPUT #1	BNC to As Required	50-Ohm Coax
DUT AUDIO OUT to Dist/Audio Meter IN	As Required to BNC	50-Ohm Coax
8-Ohm Load/HI-Z Amp Across Dist/Audio Meter Input	As Required	As Required
Power Source to DUT Power Input	As Required	As Required

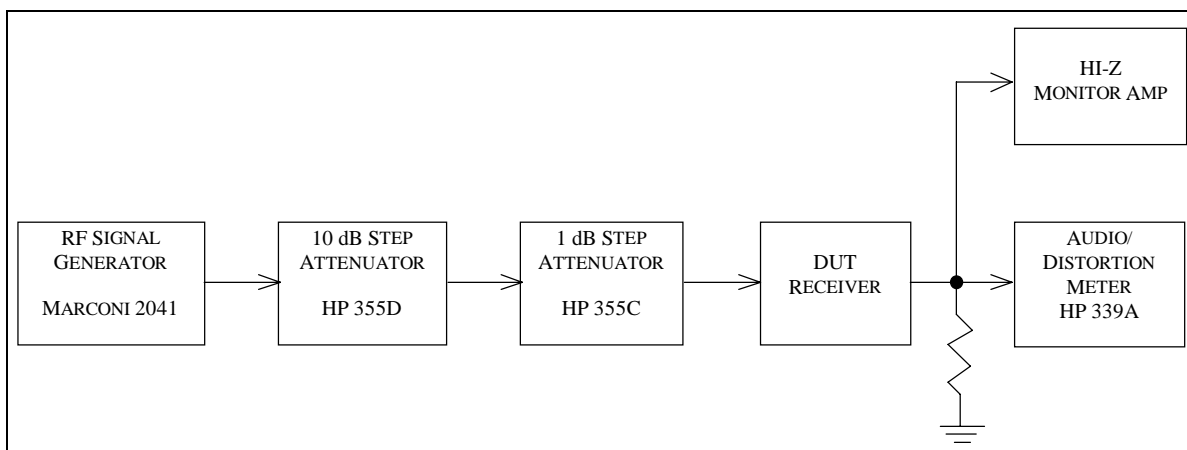

Fig. 5-6 Antenna Port Isolation Test Hook-Up

### 5.6.3 Test Procedure

5.6.3.1 Turn the DUT and all test equipment power switches to ON. Set the following controls:

<u>Instrument</u>	<u>Control</u>	<u>Position</u>
DUT	Mode	CW
	Band Selector	20 Meters
	Frequency	14.020 MHz
	IF Filters	500 Hz or Closest Available
	AGC	OFF
	Preamplifier	OFF
	10 dB Step Attn	Attenuator
RF Generator	CARRIER FREQ	14.020 MHz
	RF LEVEL	-80 dBm
	NOISE MODE	LOW NOISE
Audio/Distortion Meter	FUNCTION	REL LEVEL
	RELATIVE ADJUST	Center Rotation
	FILTERS	All Off (Out)
	INPUT RANGE	30 V
	INPUT/GND SELECT	DIS (Center)
	METER RESPONSE	NORM

5.6.3.2 Receiver hiss should be heard. Adjust the volume of the DUT and HI-Z monitor amp to the desired level. Allow all equipment at least 10 minutes warm-up time before proceeding to step 5.6.3.3.

5.6.3.4 Tune the receiver for 14.020 MHz. Rotate the Generator OUTPUT LEVEL control as required until the signal is just heard in the receiver. Adjust the INPUT RANGE and RELATIVE ADJUST controls as required to maintain approximately a mid-scale meter indication while carefully tuning the Generator CARRIER FREQ control for peak signal response.

5.6.3.5 Set the RF Generator RF switch to OFF. Decrease the Audio Meter INPUT RANGE until the meter indication is near mid-scale and the two lights above this control are out. Adjust the audio meter RELATIVE ADJUST control until the audio meter reads -6 dB on the upper scale. (Adjust the INPUT RANGE control one step in either direction if necessary.)

5.6.3.6 Set the RF Generator RF switch to ON. Rotate the generator OUTPUT LEVEL control to produce an audio meter reading of -3 dB. Ensure that the Generator CARRIER FREQ control is tuned for peak response. Results should be similar to the previously measured 20 meter MDS measured in Test 5.1. Now remove the RF Input cable from RF Input #1 and connect it to RF Input #2. Increase the Generator RF LEV Control until the meter once again shows a 3 dB increase.

5.6.3.7 Set the RF Generator RF to OFF. The audio meter should return to -6 dB. Turn the RF back on and the meter should again indicate -3 dB.

5.6.3.8 Determine the Antenna Port Isolation by computing the difference between the two MDS measurements (in dBm). Record on the Data Sheet if deemed unsatisfactory by the test engineer.

5.6.3.9 Repeat steps 5.6.3.5 and 5.6.3.6 for preamp on and any other antenna port combinations deemed appropriate by the test engineer.

## 5.7 BLOCKING GAIN COMPRESSION

5.7.1 The purpose of the Blocking Gain Compression Test is to determine the level of gain compression, or desensitization, that occurs as a result of another signal on a nearby frequency. The blocking gain compression is the difference between the level of the noise floor and the level of undesired signal that produces a 1 dB decrease of audio in a weak desired signal. Frequencies of 3.520 MHz, 14.020 MHz, 50.020 MHz, 144.020 MHz and 432.020 MHz are used for this test as appropriate for the DUT. The calculation is as follows:

$$\text{Blocking Gain Compression} = \text{Blocking Level} - \text{Noise Floor (MDS level, expressed in dBm)}$$

### 5.7.2 Test hook-up (See Fig. 5-7)

5.7.2.1 With all power switches in the OFF position, the transmitter function disabled to the fullest extent possible and the Generator RF switch OFF, connect the following:

<u>Connection</u>	<u>Connectors</u>	<u>Cable Type</u>
Signal Gen 1 output to Hybrid Combiner input 1	BNC to BNC	50-Ohm Coax
Signal Gen 2 output to Hybrid Combiner input 2	BNC to BNC	50-Ohm Coax
Hybrid Combiner output to 10-dB Step Atten. input	BNC to BNC	50-Ohm Coax
10-dB Step Attn output to 1-dB Step Attn input	BNC to BNC	50-Ohm Coax
1-dB Step Attn OUTPUT to DUT RF INPUT	BNC to As Required	50-Ohm Coax
DUT Audio OUTPUT to Dist/Audio Meter input	As Required to BNC	50-Ohm Coax
DUT Audio Output to Signal Analyzer	BNC to BNC	50-Ohm Coax
8 Ohm Load/HI-Z Amp Across Dist/Audio Meter INPUT	As Required	As Required

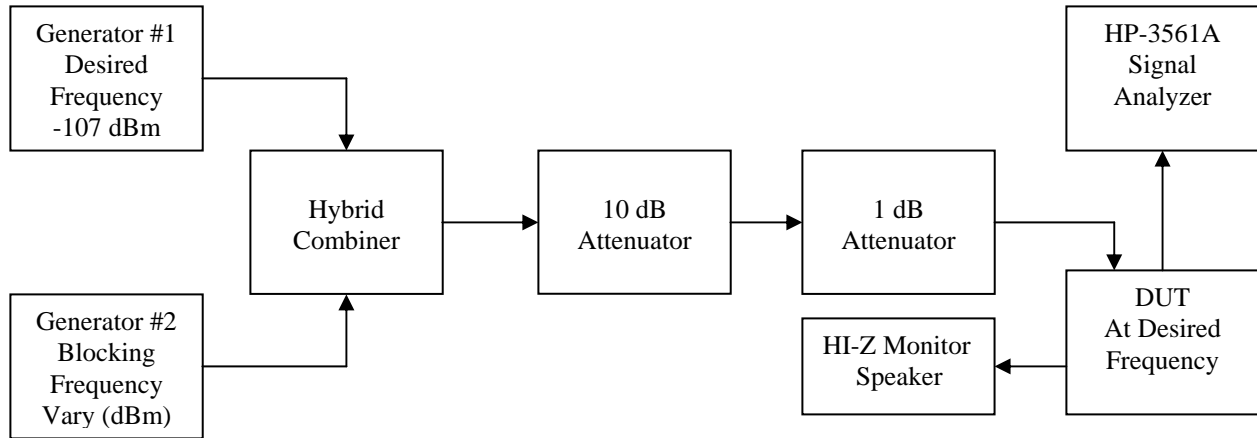

Fig. 5-7 — Blocking Dynamic Range Test Hook-up

### 5.7.3 Test Procedure

5.7.3.1 Turn the DUT and all test equipment power switches to ON. Set the following controls:

<u>Instrument</u>	<u>Position</u>	<u>Control</u>
DUT	Mode	CW
	Band Selector	3.520 MHz
	XMIT/RCV	RCV
	DRIVE or RF LEVEL	Minimum
	IF Filters	Closest Available to 500 Hz
	Any Audio Filtering	Disabled
	<b>AGC</b>	<b>OFF</b>
	VOLUME	Lowest Possible Setting
10-dB Step Attn	Attenuator	0 dB
1-dB Step Attn	Attenuator	0 dB
RF Generator #1	CARRIER FREQ	3.520 MHz
	RF LEVEL	-107 dBm
	CARR ON-OFF	ON
	NOISE MODE (UTIL)	LOW NOISE
RF Generator #2	CARRIER FREQ	3.500 MHz
	RF LEVEL	-100 dBm
	CARR ON-OFF	ON
	NOISE MODE (UTIL)	LOW NOISE
Audio/Distortion Meter	FUNCTION	REL LEVEL
	RELATIVE ADJUST	Center Rotation
	FILTERS	All OFF (Out)

INPUT RANGE	30 V
INPUT/GND SELECT	DIS (Center)
METER RESPONSE	NORM

Signal Analyzer

CENTER FREQUENCY	600 Hz
RANGE	10 dBv
VERTICAL SCALE	-10 dBv
SPAN	100 Hz
PEAK TRACK	ON

5.7.3.2 Receiver hiss should be heard. Turn the volume level all the way down. Allow all equipment at least 10 minutes warm-up time before proceeding to step 5.7.3.3.

5.7.3.3 Verify generator #1 and generator #2 are still set for 3.520 MHz and 3.500 MHz, respectively. Set Generator #2 RF switch to OFF.

5.7.3.4 Tune the receiver for 3.520 MHz. Ensure Generator #1 RF Level is set to -107 dBm. Adjust receiver volume control, turning slowly until the desired signal is barely heard in the monitor speaker (high speaker levels will damage the Signal Analyzer!). Adjust the INPUT RANGE and REL ADJUST as required to maintain approximately a mid-scale meter indication while carefully tuning the receiver for peak signal response on the meter.

5.7.3.5 Check the Signal Analyzer for a pip and adjust the DUT volume level for a relative reading of -50 dBv on the scale. Make a note of the exact reading as displayed; ex: Y= -50.23 dB. Re-adjust the INPUT RANGE for a mid scale reading on the distortion meter. From this point on, the mid-scale reading on the distortion meter will be used for quick reference for adjustment of the volume control only. **NOTE:** Do not exceed 0 dBm into the HP-3561A Signal Analyzer or damage may result to its input circuits. Start each adjustment with the DUT volume down, turning it up slowly.

5.7.3.6 Determine the 1 dB reduction point (blocking level) by Switching Generator #2 to ON and increase the RF LEVEL to a point where a 1 dB decrease in audio is observed on the Signal Analyzer. Ex: Y= -50.23 dB with GEN #2 OFF and Y= -51.23 dB with GEN #2 ON and at the blocking level. An increase of noise level is likely, especially at 5 and 2 kHz spacing. Reduce the SPAN on the signal analyzer to 10, 5 or as low as 2 Hz, as needed, to separate the desired signal from the back round noise. (It may take several minutes for the Signal Analyzer to read the relative audio level, with the SPAN set to a narrow bandwidth, each time the blocking signal level is changed)

Record the value of the blocking level (Generator #2 level + 3 dB combiner *loss* = blocking level in dBm) in 5.7.3.5 of the Data Sheet. Be sure to account for the hybrid combiner *and* any step attenuator losses.

EX: (+5.6 dBm Blocking Signal) + (-3 dBm combiner loss)) = +2.6 dBm = Blocking Level

**NOTE:** Certain SDR receivers use direct conversion and an analog to digital converter (ADC). The blocking level may be a few decibels past the point where ADC clipping occurs and may be well above 0 dBm. Do not exceed +10 dBm into DUT.

5.7.3.7 Repeat the above steps for Generator #2 set to 3.540 MHz, then at 5 and 2 kHz above and below the desired frequency, then repeat steps with Generator #1 set to: 14.020, 50.020 and 432.020 MHz. Record on data sheet.

5.7.3.8 Repeat paragraphs 5.7.3.2 to 5.7.3.7 for 20 kHz spacing above and below the desired frequency with the DUT preamp ON. If the DUT has more than one preamp setting, test all settings and record on the data sheet.

## 5.7A RECIPROCAL MIXING TEST

6.5.1 The purpose of the Phase Noise Test is to determine the level of noise generated by the reciprocal mixing of the DUT due to nearby strong signals. This test, along with Blocking Gain Compression, shows clearly how well a receiver performs with strong RF signals on nearby frequencies. A 14.025 MHz crystal controlled oscillator at +15 dBm, with low phase distortion and noise, is connected to the DUT RF input. The receiver is tuned to a series of nearby frequencies, 2, 5 & 20 kHz above and 2, 5 & 20 kHz below the oscillator's frequency. The oscillator attenuation is then reduced to a point where the level of noise is 3 dB above the noise floor of the DUT. Reciprocal Mixing is calculated for each point by use of the following equation:

$$\text{Reciprocal Mixing (in dBc)} = (\text{MDS}) - (\text{Crystal Oscillator Level at the DUT input})$$

6.5.2 Test hook-up, See Figure 5.7A

6.5.2.1 With all power switches in the OFF position and the transmitter function disabled to the fullest extent possible, connect the following:

<u>Connection</u>	<u>Connectors</u>	<u>Cable Type</u>
Low Noise Osc OUTPUT to 10-dB Step Attn INPUT	BNC to BNC	50 Ohm Coax
10-dB Step Attn OUTPUT to 1-dB Step Attn INPUT	BNC to BNC	50 Ohm Coax
1 dB Step Attn OUTPUT to DUT RF INPUT	BNC to As Required	50 Ohm Coax
DUT AUDIO OUTPUT to Dist/Audio Meter INPUT	As Required to BNC	50 Ohm Coax
8 Ohm Load/HI-Z Amp Across Dist/Audio Meter INPUT	As Required	As Required
Power Source to DUT Power Input	As Required	As Required
Power Source to Crystal Oscillator	As Required	As Required

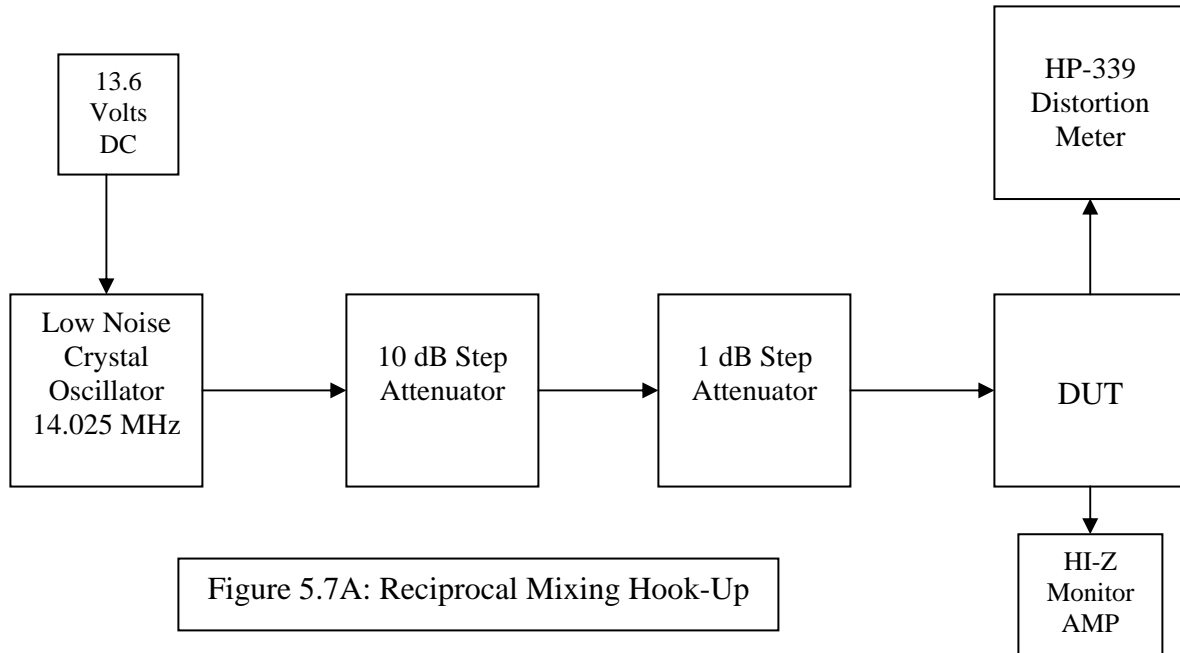

### 6.5.3 Test Procedure

6.5.3.1 Turn the DUT and Audio Distortion Meter power switches to ON. Set the following controls:

<u>Instrument</u>	<u>Control</u>	<u>Position</u>
DUT	Mode	CW
	Band Selector	20 Meters
	XMIT/RCV	RCV
	DRIVE or RF LEVEL	Minimum
	IF Filters	Same as MDS Test (5.1)
10-dB Step Attn	Attenuator	-100 dB
1-dB Step Attn	Attenuator	0 dB
Low Noise Oscillator	ON/OFF Switch	OFF
Audio/Distortion Meter	FUNCTION	REL LEVEL
	RELATIVE ADJUST	Center Rotation
	FILTERS	All OFF (Out)
	INPUT RANGE	30 V
	INPUT/GND SELECT	DIS (Center)
	METER RESPONSE	NORM

6.5.3.2 Receiver hiss should be heard. Adjust the volume to the desired level. Allow all equipment at least 10 minutes warm-up time before proceeding to step 6.5.3.3.

6.5.3.3 Tune the receiver for 14.025 MHz. Decrease the 10 dB Step Attenuator, one step at a time, until the signal is just heard in the receiver. Adjust the INPUT RANGE control as required to maintain approximately a midscale meter indication while carefully tuning the receiver for peak signal response. Tune the DUT receiver down 20 kHz from the point of peak response.

6.5.3.4 Turn the Low Noise Oscillator switch to OFF. Set the meter REL ADJUST and INPUT RANGE controls for -6 dB. Turn the Low Noise Oscillator Switch to ON. Carefully decrease the Step Attenuators for a meter indication of -3 dB. Calculate the input to the DUT, in dBm, by subtracting the step attenuator settings from the +15 dBm output of the oscillator. Record on the Data Sheet.

6.5.3.5 Continue to tune the DUT up to the following frequencies and repeat step 6.5.3.4. (NOTE: It is unnecessary to continue this procedure beyond the point that 3 dB of noise above MDS can no longer be achieved.)

14.020 MHz---Peak Response - 5 kHz (Completed in step 6.5.3.4)

14.023 MHz---Peak Response - 2 kHz

14.027 MHz---Peak Response + 2 kHz

14.030 MHz---Peak Response + 5 kHz

14.045 MHz---Peak Response + 20 kHz

6.5.3.6 Calculate Reciprocal Mixing for each test frequency by use of the following equation:

$$\text{Reciprocal Mixing (in dBc)} = (\text{MDS}) - (\text{Crystal Oscillator Level at the DUT input})$$

Record all results on the Data Sheet.

6.5.3.7 The above steps can be repeated, substituting the IFR-2041 Signal Generator for the crystal oscillator on 3.502 MHz, provided that the Generator is set for low noise mode.

**NOTE:** Direct Conversion Receivers contain Analog to Digital Converters which may have little or no reciprocal mixing up to the point of ADC Clipping. Reciprocal Mixing should be reported as:

$$\text{Reciprocal Mixing} = > (\text{MDS}) - (\text{threshold level of ADC Clipping})$$

EX: MDS = -126 dBm

ADC Clipping = +0.2 dBm

$$\text{RM} = -126 - (+0.2) = 126.2 \text{ dBc}$$

We report "better than" -126 dBc

## 5.8 TWO-TONE 2<sup>ND</sup> AND 3<sup>RD</sup> ORDER DYNAMIC RANGE TEST

5.8.1 The purpose of the Two-Tone\_Dynamic Range Test is to determine the range of signals that can be tolerated by the DUT while producing essentially no undesired spurious responses. To perform the 3<sup>rd</sup> Order test, two signals of equal amplitude and spaced 20 kHz apart, are injected into the input of the receiver. If we call these frequencies  $f_1$  and  $f_2$ , the third-order products will appear at frequencies of  $(2f_1-f_2)$  and  $(2f_2-f_1)$ . Similarly, the 2<sup>nd</sup> order test also requires two input signals of equal amplitude. The product, however, appears at a frequency of  $(f_1+f_2)$ . The intercept points are calculated for each test point. This test is performed on 3.5 MHz, 14 MHz, 50 MHz, 144 MHz and 432 MHz as

appropriate for the DUT. Additional tests are performed at various frequencies and spacings for the expanded set of tests (see data sheet).

### 5.8.2 Test hook-up (See Fig. 5-8)

**NOTE:** If proceeding from the previous Blocking Dynamic Range Test, no hook-up changes are required.

5.8.2.1 With all power switches in the OFF position and the transmitter function disabled to the fullest extent possible, connect the following:

<u>Connection</u>	<u>Connectors</u>	<u>Cable Type</u>
Signal Gen 1 output to input of Grey Amp #1	BNC to BNC	50-Ohm Coax
Signal Gen 2 output to input of Grey Amp #2	BNC to BNC	50-Ohm Coax
Grey Amp #1 output to Hybrid Combiner input	BNC to BNC	50-Ohm Coax
Grey Amp #2 output to Hybrid Combiner input	BNC to BNC	50-Ohm Coax
Hybrid Combiner output to 10-dB Step Attn input	BNC to BNC	50-Ohm Coax
10-dB Step Attn output to 1-dB Step Attn input	BNC to BNC	50-Ohm Coax
1-dB Step Attn output to Hybrid Combiner input	BNC to BNC	50-Ohm Coax
Signal Generator #3 to Hybrid Combiner input	BNC to BNC	50-Ohm Coax
Hybrid Combiner output to DUT RF input	BNC to as required	50-Ohm-Coax
DUT audio output to Dist/Audio Meter input	As Required to BNC	50-Ohm Coax
DUT to HP-3156A Signal Analyzer	BNC to BNC	50-Ohm Coax
8 Ohm Load Across Dist/Audio Meter input	As Required	As Required
Power Source to DUT Power Input	As Required	As Required

5.8.3 Test Procedure

5.8.3.1 Turn the DUT and all test equipment power switches to ON. Set the following controls:

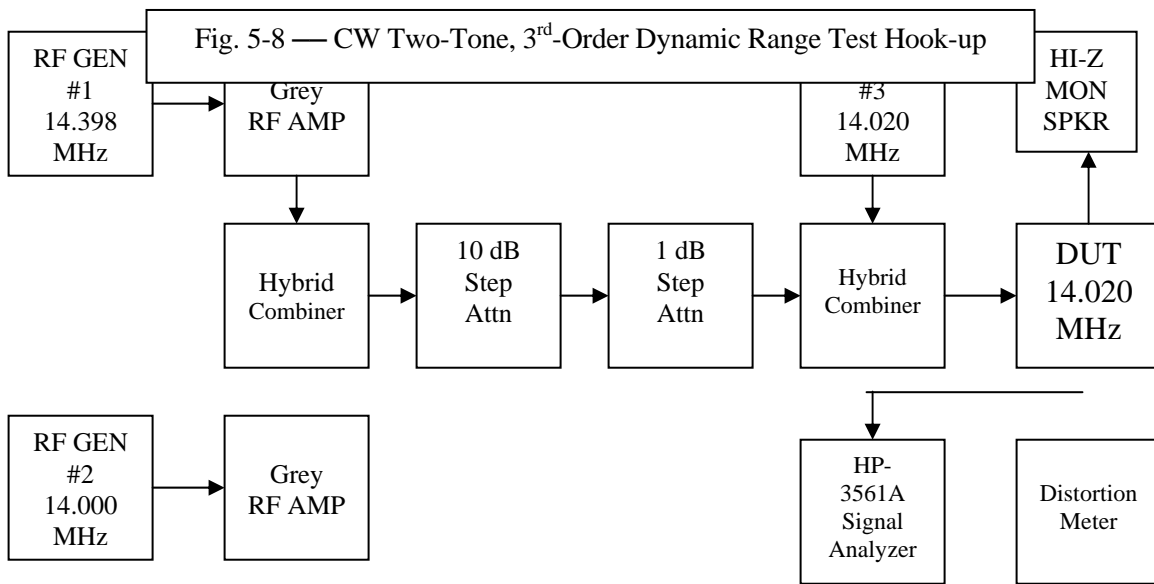

<u>Instrument</u>	<u>Control</u>	<u>Position</u>
DUT	Mode	CW
	Band Selector	20 Meters
	Frequency	14.020 MHz
	XMIT/RCV	RCV
	DRIVE or RF LEVEL	Minimum
	IF Filters	Closest Available to 500 Hz
	DUT Audio Filter(s)	Disabled
	AGC	<b>ON</b>
10-dB Step Attn	Attenuator	110 dB
1-dB Step Attn	Attenuator	0 dB
RF Generator #1	CARRIER FREQ	13.980MHz
	RF LEVEL	-18 dBm
	CARR ON-OFF	OFF
	NOISE MODE (UTIL)	LOW NOISE
RF Generator #2	CARRIER FREQ	14.000 MHz
	RF LEVEL	-18 dBm
	CARR ON-OFF	OFF
	NOISE MODE (UTIL)	LOW NOISE
RF Generator #3	CARRIER FREQ	14.020 MHz
	RF LEVEL	-97 dBm
	CARR ON-OFF	OFF
Signal Analyzer	CENTER FREQUENCY	600 Hz
	RANGE	10 dBv
	VERTICAL SCALE	-10 dBv
	SPAN	100 Hz
	PEAK TRACK	ON
Audio/Distortion Meter	FUNCTION	REL LEVEL
	RELATIVE ADJUST	Center Rotation
	FILTERS	All OFF (Out)
	INPUT RANGE	30 V
	INPUT/GND SELECT	DIS (Center)
	METER RESPONSE	NORM

#### HI-Z Monitor Amp Speaker

5.8.3.2 Receiver hiss should be heard. Adjust the volume to the lowest possible setting. Allow all equipment at least 10 minutes warm-up time before proceeding to step 5.8.3.3.

5.8.3.3 Verify RF generators #1, #2 and #3 are still set for 13.980, 14.000 and 14.020 MHz, respectively. ALL CARR ON-OFF controls *must* be in the OFF position before proceeding to the next step.

**IMPORTANT NOTE:** Before proceeding, it is imperative to insure that both Grey RF amps have the same output of 0 dBm at the output of the Hybrid Combiner. Check the outputs by hooking up a BCN to BNC cable from the combiner output to the HP-8563E spectrum analyzer, making sure the two signals are equal and at 0 dBm. Adjust the output control on each Grey amp if needed.

5.8.3.4 Set Generator #3 to CARR OFF-ON to ON. Turn up the DUT volume so it is just heard in the HI-Z monitor amp. Tune the receiver for peak response at 14.020 MHz. Decrease the audio meter INPUT RANGE control until the meter indication is near mid scale. (The two lights just above the RANGE Control should go out.) Check to make sure the Generator level is adjusted to -94 dBm, which is a -97 dBm (S5) level at the combiner output.

5.8.3.5 Look for a PIP on the Signal Analyzer. This is the **desired signal**. Center pip if needed. Adjust the DUT volume so it is close to -50 dB on the scope. Set the audio meter RELATIVE ADJUST control until meter reads -6 dB (upper scale). Adjust the INPUT RANGE switch as required to achieve this indication. From this point on, The audio meter is used as a handy reference for adjusting the DUT volume. Do NOT exceed 0 dBm at the input to the Signal Analyzer, or damage to its input circuits will result. Always start each measurement with the volume down.

5.8.3.6 Turn both the generators #1 & #2 CARR ON-OFF switches to ON. Slowly turn up the 10 dB step attenuator until a second PIP appears on the Signal Analyzer. This is the **IMD signal**. With peak tracking on, make both pips on the screen equal by adjusting the step attenuators. When both are equal, the IMD level is what the attenuators are set to, *plus* 3 dB of the combiner loss. Example: Attenuators are set to 26 dB. The IMD level would be -26 dB + 3 dB. Record the IMD level on the data sheet.

5.8.3.7 Repeat steps 5.8.3.4 to 5.8.3.7, but with Generator #1 & 2 set for 14.010 & 14.015 MHz respectively (5 kHz spacing). Repeat steps having Generator 1 & 2 at 14.016 & 14-018 MHz respectively (2 kHz spacing). Repeat steps for 2, 5 & 20 kHz spacing above the desired frequency. Record on data sheet.

**NOTE:** Measurements at 5 and 2 kHz spacing may require reducing the bandwidth on the Signal Analyzer, especially when Generator #3 is set to the MDS level (plus 3 dB) . When doing so, it will be necessary to put both pips on the scope as close together as possible before reducing the bandwidth. This is accomplished by adjust either Generator #1 or Generator #2 by small fractions of a Hertz. Slowly adjust one of the generators while watching the IMD signal, placing the IMD pip close to the desired signal pip. The SPAN may now be adjusted to a smaller bandwidth. (25 or 10 Hz works well).

5.8.3.8 Repeat the above IMD measurements, but with Generator #3 set to the MDS plus 3 dB. This results with an MDS level at the combiner output. If the MDS is -126 dBm, set the generator to -123 dBm.

5.8.3.9 Repeat steps 5.8.3.4 and 5.8.3.7 for preamp for 20 kHz spacing above and below the desired signal. Repeat if preamp has more than one setting. Return preamp to off.

5.8.3.10 Repeat IMD tests for the required frequencies and spacings shown on the data sheet.

5.8.3.11 Calculate the Two- Tone, Third Order IMD Dynamic Range for each data point.

3<sup>rd</sup> Order DR = MDS – IMD Level.

Example:

MDS = -126 dBm

IMD level = -26 dBm

3<sup>rd</sup> Order IMD DR = ( -126 dBm) – (-26 dBm) = 100 dB.

Calculate for each data point

5.8.3.12 Calculate the 3<sup>rd</sup> Order Intercept Point (IP3) for each data point using the following formulas:

**IP3 at MDS :** (1.5)(IMD DR in dB)+(MDS in dB)

Example: IMD DR = 100 dB, MDS = -126 dBm

IP3 (at MDS) = (1.5)(100 dB) + (-126 dBm) = 24 dB

$$\text{IP3 at S5: } 3 \times \left( \frac{\text{S5 IMD level} - (\text{S5 Reference})}{2} \right)$$

Example: IMD level = -15 dBm, S5 reference = -94 dBm

$$\text{IP3 at S5} = 3 \times \left( \frac{-15 \text{ dBm} - (-94 \text{ dBm})}{2} \right)$$

IP3 at S5 = 24.5 dB

We would report this as 25 dB

Record all IP3 data points on data sheet.

## 5.9 FM ADJACENT-CHANNEL SELECTIVITY TEST

5.9.1 The purpose of the FM Adjacent Channel Selectivity Test is to measure the ability of the DUT receiver to reject interference from individual undesired signals while receiving various levels of desired signal. The desired carrier signal will be at 29.000 MHz, modulated at 1000 Hz, and the offending signal will be located at adjacent nearby frequencies with 400 Hz modulation. (NOTE: The SINAD Test in 5.3 must be performed before this test can be completed.)

5.9.2 Test hook-up (See Fig. 5-9)

**NOTE:** If proceeding from the previous Two-Tone 3<sup>rd</sup>-Order Dynamic Range Test, no hook-up changes are required. Proceed directly to step 5.9.3.

5.9.2.1 With all power switches in the OFF position and the transmitter disabled, connect the following:

<u>Connection</u>	<u>Connectors</u>	<u>Cable Type</u>
Signal Gen 1 Output to Hybrid Combiner Input 1	BNC to BNC	50-Ohm Coax
Signal Gen 2 Output to Hybrid Combiner Input 2	BNC to BNC	50-Ohm Coax
Hybrid Combiner output to 10-dB Step Attn input	BNC to BNC	50-Ohm Coax
10-dB Step Attn output to 1-dB Step Attn input	BNC to BNC	50-Ohm Coax
1-dB Step Attn OUTPUT to DUT RF INPUT	BNC to As Required	50-Ohm Coax
DUT Audio Output to Dist/Audio Meter input	As Required to BNC	50-Ohm Coax
<u>Connection</u>	<u>Connectors</u>	<u>Cable Type</u>
8 Ohm Load/Hi-Z Amp Across Dist/Audio Meter IN	As Required	As Required
Power Source to DUT Power Input	As Required	As Required

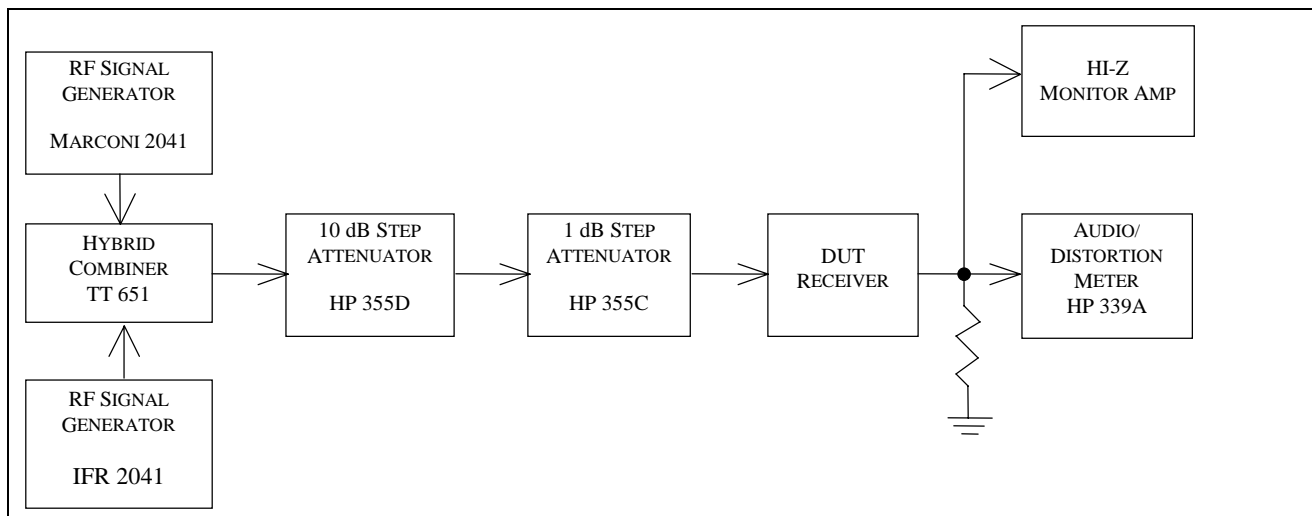

Fig. 5-9 — FM Channel Selectivity Test Hook-up

### 5.9.3 Test Procedure

5.9.3.1 Turn the DUT and all test equipment power switches to ON. Set the following controls:

<u>Instrument</u>	<u>Control</u>	<u>Position</u>
DUT	Mode	FM
	Band Selector	10 Meters
	XMIT/RCV	RCV
	DRIVE or RF LEVEL	Minimum
	IF Filters	15 kHz for FM
	Any Audio Filtering	Disabled
	Preamp	On
10-dB Step Attn	Attenuator	0 dB
	1-dB Step Attn	Attenuator
RF Generator #1	CARRIER FREQ	29.000 MHz
	RF LEVEL	-110 dBm
	NOISE MODE (UTIL)	NORMAL
	CARR ON-OFF	ON
	AM	OFF
	FM	ON
	FM DEVN	3 kHz
Modulation Frequency	1000 Hz	
RF Generator #2	CARRIER FREQ	28.980 MHz
	RF LEVEL	-110 dBm
	NOISE MODE (UTIL)	NORMAL
	CARR ON-OFF	OFF
	AM	OFF
	FM	ON
	FM DEVN	3 kHz
Modulation Frequency	400 Hz	

Instrument  
Audio/Distortion Meter

<u>Control</u>	<u>Position</u>
FUNCTION	DIST
DIST RANGE	30 %
FREQUENCY	1.0 X 1K
RELATIVE ADJUST	Center Rotation
FILTERS	All OFF (Out)
INPUT RANGE	30 V
INPUT/GND SELECT	DIS (Center)
METER RESPONSE	NORM

5.9.3.2 Receiver hiss should be heard. Adjust the volume to the desired level. Allow all equipment at least 10 minutes warm-up time before proceeding to step 5.9.3.3.

5.9.3.3 Tune the receiver for 29.000 MHz. Increase the #1 generator RF LEVEL, if necessary, until the signal is just heard in the receiver. Set the DUT volume control for a normal listening level, and carefully tune the receiver for minimum distortion. This control should be set for approximately 1/4 to 3/4 of the maximum.

5.9.3.4 Set the #1 signal generator level to produce a 12 dB SINAD response in the DUT. The generator output should be 16 dB greater than the level previously recorded in 5.3.3.5 of the Data Sheet during the initial SINAD test. (The 16 dB accounts for the attenuator and combiner losses.) The meter should now indicate 25% distortion. Change the DISTORTION RANGE to 100. Set the #2 signal generator RF switch to ON. Increase the output level of this generator until the distortion meter indicates 50% distortion or 6 dB SINAD. Note the generator and attenuator settings. Calculate the input signal level to the DUT and record in 5.9.3.4 of the Data Sheet.

5.9.3.5 Return generator and attenuator levels to their initial settings. Set the #2 generator to 29.020 MHz and set its RF switch to OFF. Repeat step 5.9.3.4.

5.9.3.6 Repeat paragraphs 5.9.3.4 and 5.9.3.5 for the following bands as applicable to the DUT: 52 MHz, 146 MHz and 440 MHz.

5.9.3.7 Calculate the adjacent channel rejection of the DUT for each test point by subtracting the 12 dB SINAD level in dBm from the 6 dB SINAD level in dBm measured in steps 5.9.3.4 and 5.9.3.5. Record in 5.9.3.9 of the Data Sheet.

Example: The 12 dB SINAD value measured in 5.3.3.6./5.3.3.7 = -113  
The 6 dB SINAD level measured per this test = -68 dBm

Adjacent channel rejection = 6 dB SINAD - 12 dB SINAD = (-68 dBm) - (-113 dBm) = 45 dB

**NOTE:** The following step need only be performed if proceeding to the FM Two-Tone 3rd-Order Dynamic-Range Test (5.10). The results will be used to determine phase noise limiting during this test.

5.9.3.8 Return generator and attenuator levels to their initial settings and turn the #2 Generator RF LEVEL and FM switches to OFF. Repeat step 5.9.3.4 with the #2 generator still set for 29.020 MHz and with the FM switch still set to OFF. Calculate the equivalent phase noise limit using the same equations as in step 5.9.3.6. This limit figure represents the FM 2-tone, 3rd-order dynamic range of an unmodulated signal.

5.9.3.9 Repeat step 5.9.3.8 for the following bands as applicable to the DUT: 52 MHz, 146 MHz and 440 MHz.

5.8.3.11 Calculate the Dynamic Range by subtracting the MDS noise floor from the IMD figure.

Example: Both RF generators are set at -14 dBm

The RF attenuators are set for -24 dB

The hybrid combiner loss is -6 dB

The receiver noise floor MDS is -135 dBm

$$\text{IMD LEVEL} = (-14 \text{ dBm}) - 24 \text{ dB} - 6 \text{ dB} = -44 \text{ dBm}$$

$$\text{IMD Dynamic Range} = \text{IMD LEVEL} - \text{NOISE FLOOR} = -44 \text{ dBm} - (-135 \text{ dBm}) = 91 \text{ dB}$$

5.8.3.12 Calculate the Third Order Intercept Point for each applicable Dynamic Range as follows:

$$\text{Third Order Intercept} = (1.5)(\text{IMD Dynamic Range in dB}) + (\text{MDS in dBm})$$

5.8.3.13 Calculate the Second Order Intercept Point using the applicable Dynamic Range as follows:

$$\text{Second Order Intercept} = (2)(\text{2nd Order IMD Dynamic Range in dB}) + (\text{MDS @ 14.020 MHz in dBm})$$

Record on Data Sheet.

5.8.3.14 The preferred method for this test is to use S5 signal levels instead of MDS levels. First, use a signal generator tuned to the DUT frequency to determine the S5 reference signal level for each of the frequencies of interest. Note: The DUT's AGC may need to be on in order to get an S-meter indication.

5.8.3.15 Perform the 2-Tone, 3rd-Order as specified above, but set the attenuators to provide an S5 indication on the DUT for each of the IMD frequencies.

5.8.3.16 Calculate the 2nd and 3rd-Order intercept points as follows:

$$\text{Third Order Intercept} = (3 * (\text{S5 IMD Level}) - (\text{S5 Reference})) / 2$$

$$\text{Second Order Intercept} = 2 * (\text{S5 IMD Level}) - (\text{S5 Reference})$$

5.8.3.17 The results of this method should show close correlation with the intercept points determined by the MDS test. If not, the test engineer determines (from the MDS and dynamic range data) which method provides the more accurate result.

5.8.3.18 For the expanded set of tests, repeat this test on additional frequencies and spacings indicated on data sheet. The swept IMD dynamic range test is performed on 14 MHz only and the data is typically presented in graphical output form in the expanded test for a clear visual indication of the receiver's blocking dynamic range performance over a wide frequency span within the 14 MHz band.

5.8.3.19 Hook-up for higher-level measurements. With some high-performance transceivers, the necessary signal levels for producing a 3<sup>rd</sup> order or 2<sup>nd</sup> order IMD response exceed the spurious-free range of the standard test setup detailed in section 5.8.2. In these cases, the following alternate hook-up is used.

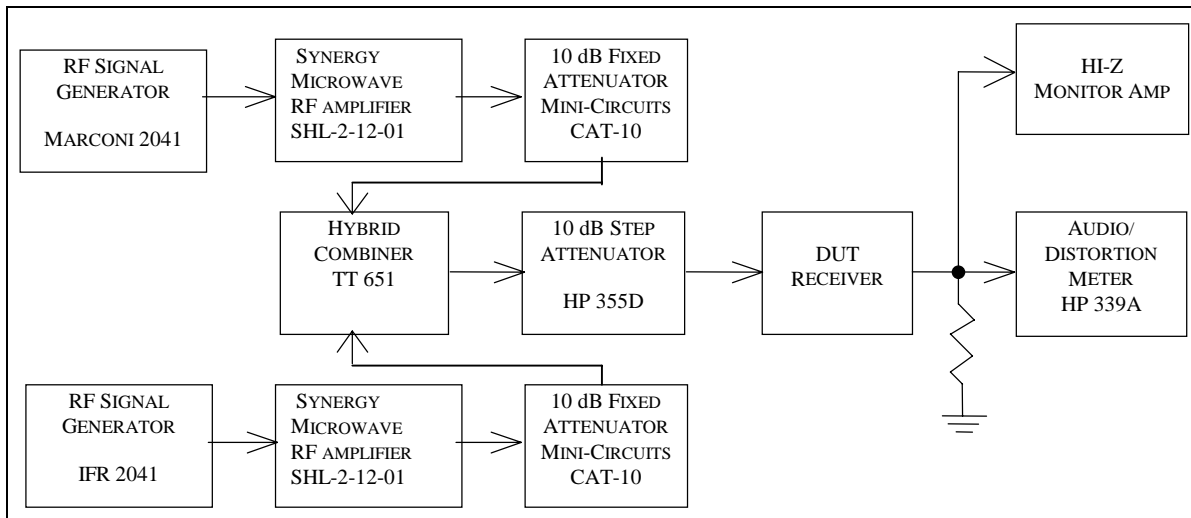

This hook-up should be used for generator levels above  $-14$  dBm to prevent problems from test fixture IMD. The Synergy Microwave amplifiers specified are 24V "ultra-linear" units that provide approximately 25 dB of gain up to  $+29$  dBm output for frequencies between 1 and 450 MHz.

## 5.10 FM TWO-TONE 3rd ORDER DYNAMIC RANGE TEST

5.10.1 The purpose of the FM Two-Tone 3<sup>rd</sup> Order Dynamic Range Test is to determine the range of signals that can be tolerated by the DUT in the FM mode while producing no spurious responses greater than the SINAD level. To perform this test, two signals,  $f_1$  and  $f_2$ , of equal amplitude and spaced 20 kHz apart, are injected into the input of the receiver. The signal located 40 kHz from the distortion product being measured is modulated at 1,000 Hz with a deviation of 3 kHz. The DUT receiver is tuned to the Third Order IMD frequencies as determined by  $(2f_1-f_2)$  and  $(2f_2-f_1)$ . The input signals are then raised simultaneously by equal amounts until 25% distortion, or the 12 dB SINAD point, is obtained.

5.10.2 Test hook-up (See Fig. 5-7)

**NOTE:** If proceeding from the previous FM Adjacent Channel Selectivity Test, no hook-up changes are required. Proceed directly to step 5.10.3.

5.10.2.1 With all power switches in the OFF position and the transmitter function disabled to the fullest extent possible, connect the following:

<u>Connection</u>	<u>Connectors</u>	<u>Cable Type</u>
Signal Gen 1 output to Hybrid Combiner input 1	BNC to BNC	50-Ohm Coax
Signal Gen 2 output to Hybrid Combiner input 2	BNC to BNC	50-Ohm Coax
Hybrid Combiner output to 10-dB Step input	BNC to BNC	50-Ohm Coax
10-dB Step Attn output to 1-dB Step Attn input	BNC to BNC	50-Ohm Coax
1-dB Step Attn output to DUT RF input	BNC to As Required	50-Ohm Coax
DUT Audio Output to Dist/Audio Meter input	As Required to BNC	50-Ohm Coax
8 Ohm Load/Hi-Z Amp Across Dist/Audio Meter Input	As Required	As Required

Power Source to DUT Power Input

As Required

As Required

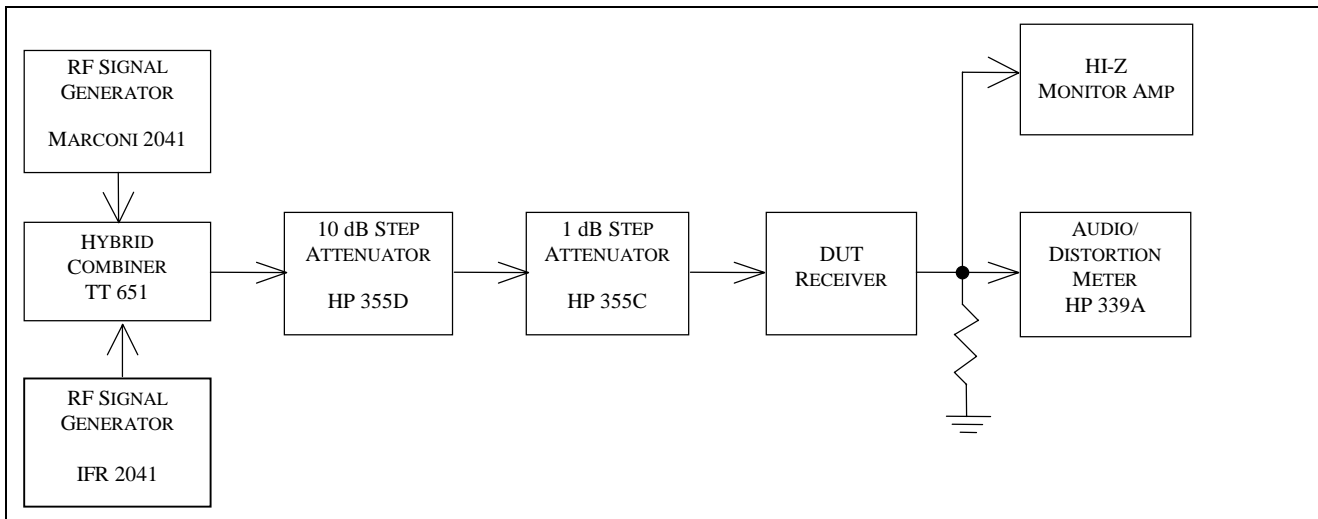

Fig. 5-10 — FM Two-Tone, 3<sup>rd</sup> Order Dynamic Range Test Hook-up

### 5.10.3 Test Procedure

5.10.3.1 Turn the DUT and all test equipment power switches to ON. Set the following controls:

<u>Instrument</u>	<u>Control</u>	<u>Position</u>
DUT	Mode	FM
	Band Selector	10 Meters
	XMIT/RCV	RCV
	DRIVE or RF LEVEL	Minimum
	IF Filters	Narrowest Available
	DUT Audio Filter(s)	Disabled
	AGC	OFF
	Preamp	ON
10-dB Step Attn	Attenuator	120 dB
	1-dB Step Attn	0 dB
RF Generator #1	CARRIER FREQUENCY	29.000 MHz
	RF LEVEL	-14 dBm
	CARR ON-OFF	ON
	NOISE MODE <sup>1</sup>	NORMAL <sup>1</sup>
	FM	On
	AM	Off
	FM DEVN	3 kHz
	Modulation Frequency	1000 Hz
RF Generator #2	CARRIER FREQUENCY	29.020 MHz
	RF LEVEL	-14 dBm
	CARR ON-OFF	ON
	NOISE MODE <sup>2</sup>	NORMAL <sup>1</sup>
	FM	On
	AM	Off

<sup>2</sup> NOTE: 3 kHz deviation is not possible at a frequency of 29 MHz unless the signal generator is in the Normal Noise Mode. Depress UTILITIES menu button for this setting.

FM DEVN	3 kHz
Modulation Frequency	1000 Hz

Audio/Distortion Meter

FUNCTION	DIST
RELATIVE ADJUST	Any
FILTERS	All OFF (Out)
DISTORTION RANGE	30%/-10 dB
INPUT RANGE	30 V
INPUT/GND SELECT	DIS (Center)
METER RESPONSE	NORM
FREQUENCY	1.0 x 1 kHz
OSCILLATOR	Any

5.10.3.2 Receiver hiss should be heard. Adjust the volume to the desired level. Allow all equipment at least 10 minutes warm-up time before proceeding to step 5.10.3.3.

5.10.3.3 Verify RF generators #1 and #2 are still set for 29.000 and 29.020 MHz, respectively. Both CARR ON-OFF controls must be in the ON position before proceeding to the next step. Set generator #1 FM switch to OFF.

5.10.3.4 Tune the receiver for the lower IMD frequency of 28.980 MHz. Decrease the attenuation of the step attenuators until the signal is just heard in the receiver. Decrease the audio meter INPUT RANGE control until the two lights just above the range switch go out. Tune the DUT for minimum distortion on the meter.

5.10.3.5 Decrease the attenuator controls until the distortion meter indicates 25% distortion. Note all attenuator settings and record receiver signal input level in 5.10.3.5 of the Data Sheet.

5.10.3.6 Set #2 generator FM switch to OFF and the #1 generator FM switch to ON. Tune the DUT to the upper IMD frequency of 29.040 MHz and repeat paragraphs 5.10.3.3 to 5.10.3.5.

5.10.3.7 Calculate and record the 3<sup>rd</sup> order dynamic range in dBm for each IMD product as follows:

$$\text{DYNAMIC RANGE} = (\text{IMD LEVEL}) - (12 \text{ dB SINAD})$$

Example: Both RF generators are set at -14 dBm

The hybrid combiner loss is -3 dB

The attenuators are set for -24 dB

The 12 dB SINAD is -122.3 dBm

The IMD level = (-14 dBm) - 3 dB - 27 dB - (122.3 dBm) = 78.3 dB

Note: An FM 2-tone, 3rd-order dynamic range that is noise-limited will appear to be better than it actually is due to the additional signal necessary to overcome the increased noise. If the calculated FM 2-tone, 3rd-order dynamic range is greater than the phase noise limit determined by the adjacent channel selectivity test, then the actual dynamic range is the phase noise limit figure and the measurement is noise-limited.

5.10.3.8 Repeat paragraphs 5.10.3.3 to 5.10.3.7 for the following frequency bands as applicable to the DUT: 52 MHz, 146 MHz and 440 MHz. Also perform this test at a spacing of 10 MHz on these bands.

## 5.11 AUDIO POWER OUTPUT TEST

5.11.1 The purpose of the Audio Power Output Test is to measure the audio output voltage developed by the DUT at 1,000 Hz. The manufacturer’s specified load and distortion is used for this test. If unspecified, the power is measured with an 8 Ohm load at 10% distortion. The audio power is then calculated by the equation:

$$P_{audio} = \frac{V^2}{8\Omega}$$

5.11.2 Test hook-up (See Fig. 5-8)

**NOTE:** 1) If proceeding from the previous FM Two-Tone 3<sup>rd</sup> Order Dynamic Range Test, only the hook-up changes shown with a dotted line are required.

2) Do not use headphone audio output for this test. It will not develop full power.

5.11.2.1 With all power switches in the OFF position and the transmitter function disabled to the fullest extent possible, connect the following:

<u>Connection</u>	<u>Connectors</u>	<u>Cable Type</u>
Signal Gen output to 10-dB Step Attn input	BNC to BNC	50-Ohm Coax
10-dB Step Attn output to 1-dB Step Attn input	BNC to BNC	50-Ohm Coax
1-dB Step Attn output to DUT RF input	BNC to As Required	50-Ohm Coax
DUT Audio output to Dist/Audio Meter input	As Required to BNC	50-Ohm Coax
Speaker Load/Hi-Z Amp Across Dist/Audio Meter INPUT (See Note 1)	As Required	As Required
Power Source to DUT Power Input	As Required	As Required

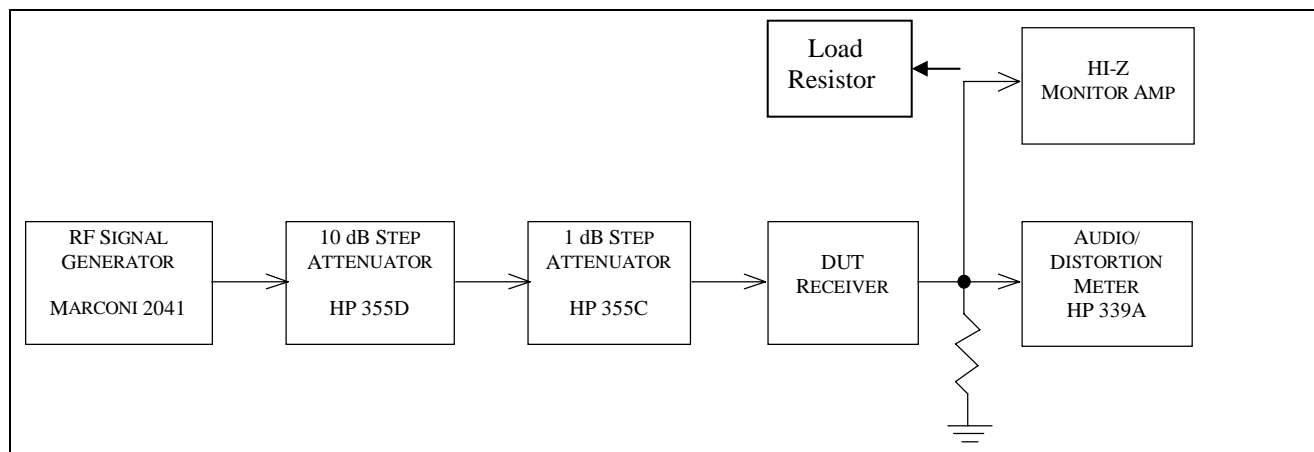

Fig. 5-11 — Audio Power Output Test Hook-up

### 5.11.3 Test Procedure

5.11.3.1 Turn the DUT and all test equipment power switches to ON. Set the following controls:

<u>Instrument</u>	<u>Control</u>	<u>Position</u>
DUT	Mode	USB
	AGC	Enabled
	Band Selector	20 Meters
	Frequency Tune	14.200 MHz
	XMIT/RCV	RCV
	DRIVE or RF LEVEL	Minimum
	IF Filters	Widest Available
	Any Audio Filter	Disabled
10-dB Step Attn	Attenuator	10 dB
1-dB Step Attn	Attenuator	0dB
RF Generator	FREQUENCY TUNE	14.200 MHz
	OUT LEVEL	-80 dBm
	RF	ON
	AM	OFF
	FM	OFF
Audio/Distortion Meter	FUNCTION	DIST
	RELATIVE ADJUST	Any
	FILTERS	All OFF (Out)
	INPUT RANGE	30 V
	DISTORTION RANGE	30%
	INPUT/GND SELECT	DIS (Center)
	METER RESPONSE	NORM
FREQUENCY	1.0 X 1 kHz	

5.11.3.2 Receiver hiss should be heard. Adjust the volume to the desired level. Allow all equipment at least 10 minutes warm-up time before proceeding to step 5.8.3.3.

5.11.3.3 Select the appropriate speaker load resistor which matches the DUT audio output impedance.

5.11.3.4 Increase the generator OUTPUT LEVEL control, if necessary, until the signal is just heard in the receiver.

5.11.3.5 Tune the DUT for peak response on the receiver S meter. Increase the OUTPUT LEVEL control for an S9 signal.

5.11.3.6 Tune the DUT for approximately 1 kHz audio output. Carefully adjust the DUT tuning control so that both lights above the FREQUENCY control should be out. Disconnect or turn-off the HI-Z amplifier to eliminate the otherwise loud and unpleasant 1,000 kHz tone during this test.

5.11.3.7 Slowly increase the DUT audio gain until the meter indicates the manufacturer's specified distortion. If unspecified, increase the audio gain for a distortion of 10%. (If the distortion is under 10% at maximum volume, be sure to note the maximum distortion level on the Data Sheet.)<sup>3</sup>

<sup>3</sup> If the manufacturer specifies audio power output at other than 10% THD, or other than an 8Ω load, test to specified conditions.

5.11.3.8 Change the Meter FUNCTION control to INP LEVEL. Adjust the INPUT RANGE as necessary (over range lights should be out.) Read the audio output voltage on the correct scale of the Distortion/Audio meter and record on the Data Sheet.

5.11.3.9 Calculate the audio power using the following equation:

$$P_{\text{audio}} = V^2/8$$

If the manufacturer's specified load used for this test was other than 8 ohms, be sure to substitute the correct load impedance when calculating power output. Record on the Data Sheet.

## 5.12 AUDIO AND IF FREQUENCY RESPONSE TEST

5.12.1 The purpose of the Audio and IF Frequency Response Test is to measure the audio frequencies at which the receiver audio output drops by 6 dB from the peak signal response. The frequency response is then calculated by taking the difference between the upper and lower frequency.

5.12.2 Test hook-up (See Fig. 5-12)

**NOTE:** If proceeding from the previous Audio Power Output Test, only the hook-up changes shown in the diagram are required. Proceed to step 5.12.3.

5.12.2.1 With all power switches in the OFF position and the transmitter function disabled to the fullest extent possible, connect the following:

<u>Connection</u>	<u>Connectors</u>	<u>Cable Type</u>
Signal Gen OUTPUT to 10 dB Step Attn INPUT	BNC to BNC	50-Ohm Coax
10-dB Step Attn OUTPUT to 1-dB Step Attn INPUT	BNC to BNC	50-Ohm Coax
1-dB Step Attn OUTPUT to DUT RF INPUT	BNC to As Required	50-Ohm Coax
DUT AUDIO OUTPUT to Dist/Audio Meter INPUT	As Required to BNC	50-Ohm Coax
Speaker Load to Oscilloscope Input	As Required to BNC	50-Ohm Coax
Speaker Load/HI-Z Amp Across Dist/Audio Meter INPUT	As Required	As Required
Power Source to DUT Power Input	As Required	As Required

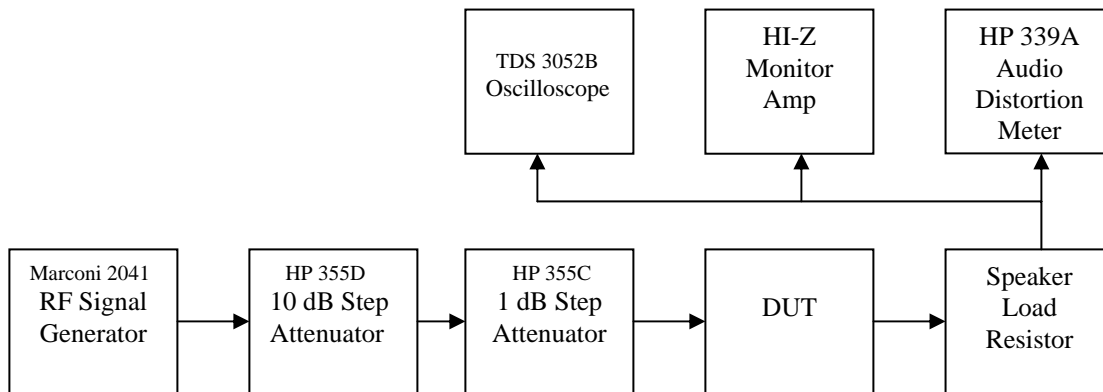

Figure 5-12: Audio and IF Frequency Response Test Hook-up

### 5.12.3 Test Procedure

5.12.3.1 Turn the DUT and all test equipment power switches to ON. Set the following controls:

<u>Instrument</u>	<u>Control</u>	<u>Position</u>
DUT	Mode	USB
	Band Selector	20 Meters
	Frequency	14.200 MHz
	XMIT/RCV	RCV
	DRIVE or RF LEVEL	Minimum
	IF Filters	Widest Normal SSB
	AGC	ON
10-dB Step Attn	Attenuator	-70 dB
	1-dB Step Attn	Attenuator
RF Generator	FREQUENCY	14.200 MHz
	OUTPUT LEVEL	-110 dBm
	RF	ON
	AM	OFF
	FM	OFF
Audio/Distortion Meter	FUNCTION	REL LEVEL
	RELATIVE ADJUST	Center Rotation
	FILTERS	All OFF (Out)
	INPUT RANGE	30 V
	INPUT/GND SELECT	DIS (Center)
METER RESPONSE	NORM	

5.12.3.2 Set the DUT, Signal Generator and Audio Distortion Meter and Frequency Counter power switches to ON. Receiver hiss should be heard. Adjust the volume to the desired level. Allow all equipment at least 10 minutes warm-up time before proceeding to step 5.12.3.3.

5.12.3.3 Set the RF generator to 14.200 MHz. Tune the DUT receiver to the Generator frequency. Rotate the generator OUTPUT LEVEL control to a point where the S meter on the DUT just before it starts to move. Turn off the AGC.

5.12.3.4 Adjust the INPUT RANGE control as required to maintain approximately a mid-scale meter indication while carefully tuning the Generator for peak signal response on the meter.

**NOTE:** Set the Generator to 20 dB above the MDS level if the AGC cannot be disabled.

5.12.3.6 Record the IF filter bandwidth in 5.12.3.6 of the data sheet. Set the RELATIVE ADJUST for a  $-1$  dB indication on the meter. Tune the Generator downward in frequency until the meter indicates  $-7$  dB. Adjust the oscilloscope for amplitude and frequency to show several sine waves. Using the *measure* function on the oscilloscope, the frequency of the waveform is displayed. Record Frequency indication in 5.12.3.6 of the Data Sheet. Return the Generator output to its initial level and the DUT to the peak response frequency. The meter should again indicate  $-1$  dB.

5.12.3.7 Tune the Generator upward in frequency until the meter indicates  $-7$  dB. Adjust the oscilloscope for amplitude and frequency to show several sine waves. Using the *measure* function on the oscilloscope, the frequency of the waveform is displayed. Record the Frequency indication in 5.12.3.7 of the Data Sheet. Return the Generator output to its initial level and the DUT to the peak response frequency. The meter should again indicate  $-1$  dB. Subtract the lower  $-6$  dB Frequency indication from the upper and record this difference in the space provided.

5.12.3.8 Tune the generator for peak response and repeat paragraphs 5.12.3.6 to 5.12.3.7 for all remaining DSP, SSB and CW IF filters and IF filter combinations.

#### *AM Audio Frequency Response*

5.12.3.9 Connect the output of the HP-8116A Function Generator to the EXT MOD INPUT of the RF Generator. Adjust the generators to provide an S8 to S9 signal with 80% modulation at approximately 1000 Hz.

5.12.3.10 Tune the DUT for peak audio response as indicated by the Audio Meter. Increase the modulation frequency until approximately a 6 dB drop is observed. Again, tune the DUT for peak audio response. Record the IF filter bandwidth in 5.12.3.10 of the data sheet. Record the modulation frequency that produces peak meter response in 5.12.3.10 of the Data Sheet.

5.12.3.11 Adjust the modulation frequency for peak response. Set the RELATIVE ADJUST for a  $-1$  dB indication on the meter. Reduce the modulation frequency until the meter indicates  $-7$  dB. Record the modulation frequency in 5.12.3.10 of the Data Sheet. Return the modulation to its initial frequency and the meter should again indicate  $-1$  dB.

5.12.3.12 Increase the modulation frequency until the meter indicates  $-7$  dB. Record the modulation frequency in 5.12.3.10 of the Data Sheet. Return the modulation to its initial frequency. The meter should again indicate  $-1$  dB. Subtract the lower  $-6$  dB frequency indication from the upper and record this difference in the space provided.

5.12.3.13 Repeat paragraphs 5.12.3.10 to 5.12.3.12 for all remaining AM filters.

### **5.13 SQUELCH SENSITIVITY TEST**

5.13.1 The purpose of the Squelch Sensitivity Test is to determine the level of the input signal required to break the squelch at the threshold point . This test is performed for both FM and SSB.

5.13.2 Test hook-up (See Fig. 5-13)

**NOTE:** If proceeding from the previous Audio & IF Frequency Response Test, no hook-up changes except removal of the oscilloscope is required. Proceed to step 5.13.3.

5.13.2.1 With all power switches in the OFF position and the transmitter disabled, connect the following:

<u>Connection</u>	<u>Connectors</u>	<u>Cable Type</u>
Signal Gen OUTPUT to 10-dB Step Attn INPUT	BNC to BNC	50-Ohm Coax
10-dB Step Attn OUTPUT to 1-dB Step Attn IN	BNC to BNC	50-Ohm Coax
1-dB Step Attn OUTPUT to DUT RF INPUT	BNC to As Required	50-Ohm Coax
DUT Audio OUTPUT to Dist/Audio Meter IN	As Required to BNC	50-Ohm Coax
8-Ohm Load/HI-Z Amp Across Dist/Audio Meter INPUT	As Required	As Required
Power Source to DUT Power Input	As Required	As Required

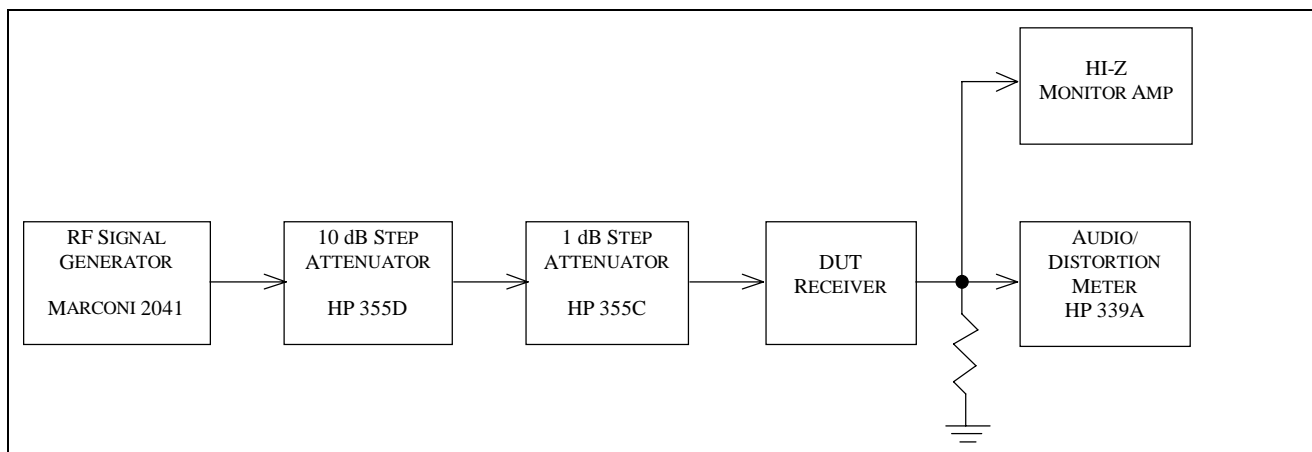

Fig. 5-13 — FM Squelch Sensitivity Test Hook-up

5.13.3 Test Procedure

5.13.3.1 Turn the DUT and all test equipment power switches to ON. Set the following controls:

<u>Instrument</u>	<u>Control</u>	<u>Position</u>
DUT	Mode	FM
	Band Selector	10 Meters
	Frequency	29.000 MHz
	XMIT/RCV	RCV
	DRIVE or RF LEVEL	Minimum
	IF Filters	Suitable for FM
	AGC	OFF
	Preamp	ON
	Any Audio Filter	Disabled

10-dB Step Attn	Attenuator	10 dB
1-dB Step Attn	Attenuator	0 dB
RF Generator	FREQUENCY TUNE	29.000 MHz
	OUT LEVEL	-110 dBm
	AM	OFF
	FM	INT
	DEVIATION	3 kHz
	MODULATION FREQ	1000 Hz
	RF	ON
Audio/Distortion Meter	FUNCTION	REL LEVEL
	RELATIVE ADJUST	Center Rotation
	FILTERS	All OFF (Out)
	INPUT RANGE	30 V
	INPUT/GND SELECT	DIS (Center)
	METER RESPONSE	NORM

5.13.3.2 Receiver hiss should be heard. Adjust the volume to the desired level. Allow all equipment at least 10 minutes warm-up time before proceeding to step 5.13.3.3.

5.13.3.3 Increase the Generator OUTPUT LEVEL control, if necessary, until the signal is just heard in the receiver. Adjust the INPUT RANGE control as required to maintain approximately a mid-scale meter indication while carefully tuning the receiver for minimum distortion (FM) or peak signal response (SSB) as appropriate.

5.13.3.4 Set the RF Generator RF switch to OFF. Carefully adjust the squelch control on the DUT to just past the threshold point, closing the receiver. Set the RF switch back to ON. *Slowly* increase the Generator output to a level that holds the receiver open continuously without dropping out. (Use the step attenuator controls as necessary to obtain the threshold point.) Note the attenuator settings and generator output. Calculate the level of the input signal to the DUT and record on the Data Sheet. Return the step attenuators to their initial settings.

5.13.3.5 Repeat paragraphs 5.13.3.3 to 5.13.3.4 for the following frequency bands, as appropriate to the DUT: 52 MHz, 146 MHz and 440 MHz.

5.13.3.7 Return the attenuator controls to their initial settings. Set the generator for 14.200 and the FM switch to OFF. Set the DUT for USB at 14.200 MHz. Repeat paragraphs 5.13.3.4 through 5.13.3.4, if squelch is available for USB, EXCEPT this time, set the Generator OUTPUT LEVEL to a point where the squelch opens momentarily and closes again. Calculate the level of the input signal and record on the Data Sheet.

**(Note: AGC may have to be enabled)**

## 5.14 S METER TEST

5.14.1 The purpose of the S Meter Test is to determine the level of RF input signal required to produce an S9 indication on the receiver S Meter. This test is performed with the DUT in the CW mode at frequencies of 1.020, 14.020, 52.020, 146.020 and 440.020 MHz as appropriate for the DUT. An S9+20 dB signal is also used to check for significant S Meter deviation. The IF filter is set for the closest bandwidth to 500 Hz.

5.14.2 Test hook-up (See Fig. 5-14)

**NOTE:** If proceeding from the previous Squelch Sensitivity Test, no hook-up changes are required. Proceed to step 5.14.3.

5.14.2.1 With all power switches in the OFF position and the transmitter disabled, connect the following:

<u>Connection</u>	<u>Connectors</u>	<u>Cable Type</u>
Signal Gen OUTPUT to 10-dB Step Attn INPUT	BNC to BNC	50-Ohm Coax
10-dB Step Attn OUTPUT to 1-dB Step Attn IN	BNC to BNC	50-Ohm Coax
1-dB Step Attn OUTPUT to DUT RF INPUT	BNC to As Required	50-Ohm Coax
DUT Audio Output to Dist/Audio Meter Input	As Required to BNC	50-Ohm Coax
8 Ohm Load/HI-Z Amp to Dist/Audio Meter Input	As Required	As Required
Power Source to DUT Power Input	As Required	As Required

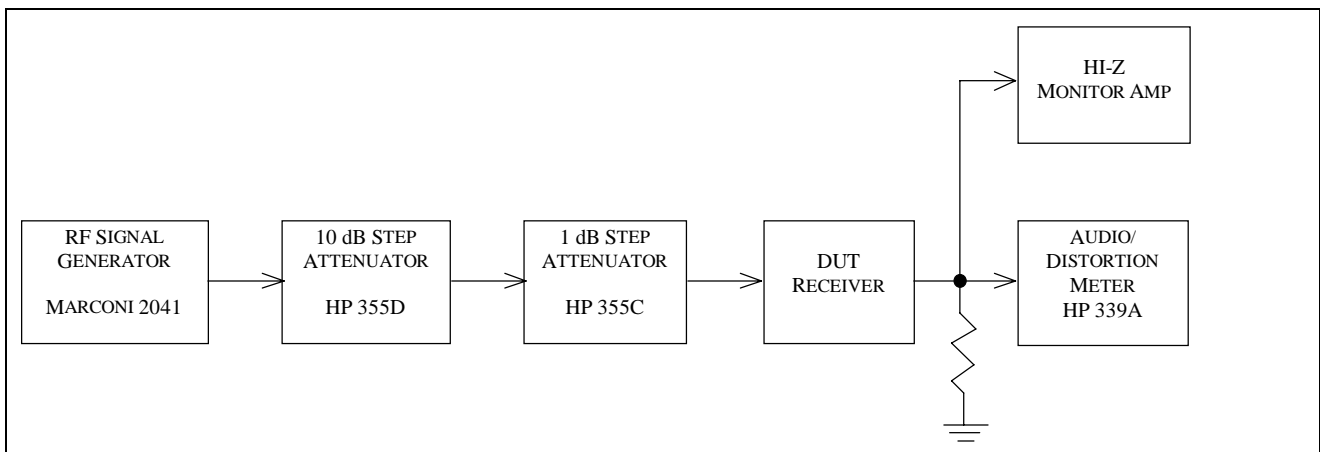

Fig. 5-14 — S-meter Test Hook-up

### 5.14.3 Test Procedure

5.14.3.1 Turn the DUT and all test equipment power switches to ON. Set the following controls:

<u>Instrument</u>	<u>Control</u>	<u>Position</u>
DUT	Mode	SSB
	Band Selector	20 Meters
	Frequency	14.200 MHz
	XMIT/RCV	RCV
	DRIVE or RF LEVEL	Minimum
	IF Filters	Closest to 500 Hz
	AGC	ON
	Preamplifier	OFF
10-dB Step Attn	Attenuator	-10 dB
1-dB Step Attn	Attenuator	0 dB
RF Generator	FREQUENCY TUNE	14.200 MHz
	OUT LEVEL	-100 dBm
	RF	ON
	AM	OFF
	FM	OFF

Audio/Distortion Meter	FUNCTION	REL LEVEL
	RELATIVE ADJUST	Center Rotation
	FILTERS	All OFF (Out)
	INPUT RANGE	30 V
	INPUT/GND SELECT	DIS (Center)
	METER RESPONSE	NORM

5.14.3.2 Receiver hiss should be heard. Adjust the volume to the desired level. Allow all equipment at least 10 minutes warm-up time before proceeding to step 5.14.3.3.

5.14.3.3 Rotate the Generator OUTPUT LEVEL control as required until the signal is just heard in the receiver. Adjust the INPUT RANGE control as required to maintain approximately a mid-scale meter indication while carefully tuning the receiver for peak signal response.

5.14.3.4 Increase the Generator OUTPUT LEVEL control for approximately an S9 indication. Adjust the DUT tuning control for maximum S Meter indication, then set the Generator output for an exact indication of S9. Rock the DUT tuning control back-and-forth to ensure the S Meter is still peaked on the signal. Note the Generator output and attenuator settings and record the input signal level in microvolts to the DUT in the 5.14.3.4 of the Data Sheet.

5.14.3.5 Increase the Generator output for an S9+20 dB S Meter indication. Check the appropriate box in 5.14.3.5 if an approximately 20 dB increase in generator output was required. If not, record levels and settings as in step 5.14.3.4.

5.14.3.6 Repeat steps 5.14.3.4 through 5.14.3.5 with DUT preamp on.

5.14.3.7 Return DUT preamp to off and repeat steps 5.14.3.3 to 5.14.3.6 for frequencies of 1.020, 52.020, 146.020 and 432.020 MHz.

## 5.15 IN-BAND IMD TEST

5.15.1 The purpose of the In-Band IMD Test is to measure the intermodulation-distortion (IMD) products present in the audio output of the receiver. *This test is typically performed on units that will undergo the expanded set of tests.* The receiver will be operated in the SSB mode at 14.200 MHz. Two input signals, spaced 200 Hz apart, are applied to the DUT and adjusted for equal output amplitude. (The audio tones are approximately 900 and 1100 Hz.) The input signals are adjusted for approximately a single tone n S-9 level and the audio output is observed on the Spectrum Analyzer. The tones are set for a 0 dB level for a single tone reference. (This is unlike the transmit two-tone test, where the -6 dB is used for a PEP reference level.) The AGC fast option is used for this test.

5.15.2 Test Hook-up (See FIGURE 5-15)

Note: If proceeding from the previous S-Meter Test, only the hook-up changes shown with a dotted line are required.

5.15.2.1 With all power switches in the OFF position, the transmitter function disabled to the fullest extent possible and each Generator RF OFF, connect the following:

<u>Connection</u>	<u>Connectors</u>	<u>Cable Type</u>
Signal Gen 1 Output to Hybrid Combiner Input 1	BNC to BNC	50-Ohm Coax
Signal Gen 2 Output to Hybrid Combiner Input 2	BNC to BNC	50-Ohm Coax
Hybrid Combiner Output to 10-dB Step Attn Input	BNC to BNC	50-Ohm Coax
10-dB Step Attn Output to 1-dB Step Attn IN	BNC to BNC	50-Ohm Coax
1-dB Step Attn Output to DUT RF Input	BNC to As Req.	50-Ohm Coax
8 Ohm Load / HI-Z Amp across DUT Audio Output	As Req.	As Required
DUT Audio Output to Audio Attn Pad Input	As Req. to BNC	50-Ohm Coax
Audio Attn Pad Output to Spectrum Analyzer Input	BNC to BNC	Coax
Power Source to DUT Power Input	As Req.	As Req.

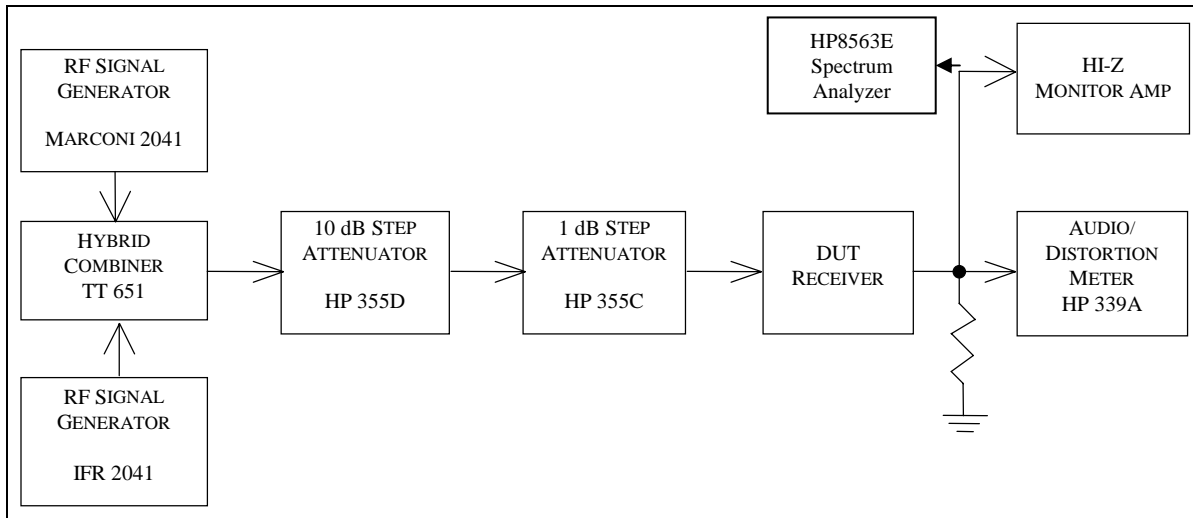

Figure 5-15 In-Band IMD Test Setup

### 5.15.3 Test Procedure

5.15.3.1 Turn the DUT and all test equipment power switches to ON. Set the following controls:

<u>Instrument</u>	<u>Control</u>	<u>Position</u>
DUT	Mode	USB
	Band Selector	20 Meters
	Frequency	14.20000 MHz
	XMIT/RCV	RCV
	DRIVE or RF LEVEL	Minimum
	IF Filters	SSB Widest Available

	Any Audio Filtering	Disabled
	AGC	Fastest Available
	AF Gain (Volume Control)	Minimum
10-dB Step Attn	Attenuator	10 dB
1-dB Step Attn	Attenuator	0 dB
RF Generator #1	CARRIER FREQ	14.2009 MHz
	RF LEVEL	-63 dBm
	CARRIER ON-OFF	ON
	AM	OFF
	FM	OFF
	NOISE MODE (UTIL)	LOW NOISE
RF Generator #2	CARRIER FREQ	14.2011 MHz
	RF LEVEL	-63 dBm
	CARRIER ON-OFF	ON
	AM	OFF
	FM	OFF
	NOISE MODE (UTIL)	LOW NOISE

<u>Instrument</u>	<u>Control</u>	<u>Position</u>
Spectrum Analyzer	START FREQ - STOP FREQ	0 - 2 kHz
	REF LEV (AMPLITUDE)	-10 dBm
	ATTEN (AMPLITUDE)	20 dB
	RES (BW)	10 Hz
	VIDEO BW (BW)	10 kHz
	THRESHOLD (DISPLAY)	-80 dBm
	SWP TIME (SWEEP)	AUTO (1.3 s)

CAUTION: The input to the spectrum analyzer at no time should be greater than +10 dBm (0.707 Vrms). Damage to this instrument will occur at an input level of +30 dBm (7.07 Vrms) or greater. It is recommended to monitor the audio on the analyzer display at all times during this test - especially when increasing the AF Gain Control or decreasing the variable attenuators.<sup>1</sup>

5.15.3.2 Slowly increase the AF Gain control of the DUT. Receiver hiss should be heard. Adjust the volume to the desired level. Be careful not to exceed the -10 dBm reference limit on the analyzer display. Allow all equipment at least 10 minutes warm-up time before proceeding to step 5.15.3.3.

5.15.3.3 Tune the DUT for peak response as indicated by the receiver's S-Meter. Adjust #1 Generator RF LEVEL control, if necessary, for an S-9 indication. Set the #2 Generator RF switch to ON and set for the same output level as Generator #1. Both pips should now be clearly visible on the Spectrum analyzer display

5.15.3.4 Adjust the DUT Tuning control, if necessary, for the two tones to be centered on the spectrum analyzer display. The scan rate may be increased temporarily by adjusting the SWP TIME (SWEEP) control. (NOTE: Analyzer calibration is lost once the scan rate is increased beyond the point MEAS UNCAL appears on the screen.) Adjust the attenuators and DUT AF Gain control for an approximate indication of -10 dBm (top reference line) on the spectrum analyzer.

5.15.3.5 If necessary, slow the scan rate down to a point where the analyzer is again in calibration. Carefully adjust the #2 RF Generator RF LEVEL control for the second pip to be equal to the first pip. Adjust the DUT audio output so that both pips are now at the -10 dBm reference (top) line of the spectrum analyzer display. Re-adjust, if necessary, the #2 RF Generator RF LEVEL Control if the two tones are no longer equal in amplitude.

5.15.3.6 Take a single sweep by depressing the SGL SWEEP (SWEEP) button. Plot and save to an appropriately named file.

5.15.3.7 Repeat if desired for any other AGC options as deemed appropriate by the Test Engineer.

---

<sup>1</sup> "Woe be unto he who breaks this thing." ---- Edward F. Hare, W1RFI

## 5.16 NOTCH FILTER TEST

5.16.1 The purpose of the Notch Filter Test is to determine the notch depth of any and all applicable receiver filters. Two 20-meter input signals, spaced 1200 Hz apart, are applied to the DUT and adjusted for equal output amplitudes. The receiver notch filter is then set to null the undesired upper audio tone. The lower audio tone is adjusted to provide a 0-dB reference on the spectrum analyzer display. The depth of the notch filter is then determined by comparing the difference in levels between the two tones. Similar tests are performed with receivers having DSP auto-notch capabilities. In addition, the time to notch, or notch attack time will also be measured for DSP units.

5.16.2 Test Hook-up (See FIGURE 5-16) Note: If proceeding from the previous In-Band IMD Test, only the hook-up changes shown with a dotted line are required.

5.16.2.1 With all power switches in the OFF position, the transmitter function disabled to the fullest extent possible and each Generator RF OFF, connect the following:

<u>Connection</u>	<u>Connectors</u>	<u>Cable Type</u>
Signal Gen 1 Out to Hybrid Combiner IN 1	BNC to BNC	50-Ohm Coax
Signal Gen 2 Out to Hybrid Combiner In 2	BNC to BNC	50-Ohm Coax
Hybrid Combiner Output to 10-dB Step Attn Input	BNC to BNC	50-Ohm Coax
10-dB Step Attn Output to 1-dB Step Attn Input	BNC to BNC	50-Ohm Coax
1-dB Step Attn Output to DUT RF Input	BNC to As Req.	50-Ohm Coax
DUT Audio Output to Dist/Audio Meter IN	As Req. to BNC	50-Ohm Coax
8 Ohm Load / HI-Z Amp across Dist/Audio Meter Input	As Req.	As Req.
20 dB Audio Pad (Attn) Output to Spectrum Analyzer Input	BNC to BNC	Coax
Power Source to DUT Power Input	As Req.	As Req.

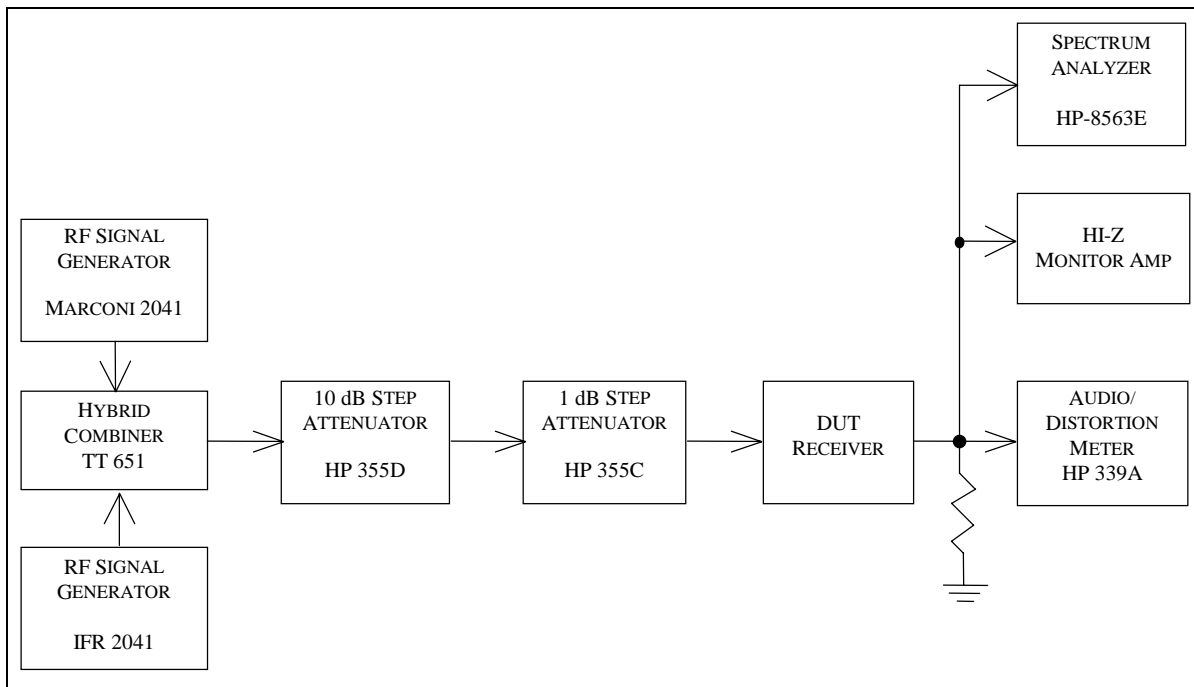

Figure 5-16 Notch Filter Test Hook-Up

### 5.16.3 Test Procedure

5.16.3.1 Turn the DUT and all test equipment power switches to ON. Set the following controls:

<u>Instrument</u>	<u>Control</u>	<u>Position</u>	
DUT	Mode	USB	
	Band Selector	20 Meters	
	Frequency	14.200 MHz	
	XMIT/RCV	RCV	
	DRIVE or RF LEVEL	Minimum	
	IF Filters	SSB Widest Available	
	Any Audio Filtering	Disabled	
	AGC	OFF (if available) or Fast	
	Notch Filter	OFF	
AF Gain (Volume Control)	Minimum		
10-dB Step Attn	Attenuator	10 dB	
	1-dB Step Attn	Attenuator	0 dB
RF Generator #1	CARRIER FREQ	14.2000 MHz	
	RF LEVEL	-80 dBm	
	CARRIER ON-OFF	ON	
	AM	OFF	
	FM	OFF	
	NOISE MODE (UTIL)	LOW NOISE	
RF Generator #2	CARRIER FREQ	14.2012 MHz	
	RF LEVEL	-80 dBm	
	CARRIER ON-OFF	ON	
	AM	OFF	
	FM	OFF	
	NOISE MODE (UTIL)	LOW NOISE	

Audio/Distortion Meter	FUNCTION	REL LEVEL
	RELATIVE ADJUST	Center Rotation
	FILTERS	All Off (Out)
	INPUT RANGE	30 V
	INPUT/GND SELECT	DIS (Center)
	METER RESPONSE	NORM
Spectrum Analyzer	START FREQ - STOP FREQ	0 – 3 kHz
	REF LEV (AMPLITUDE)	–10 dBm
	ATTEN (AMPLITUDE)	20 dB
	RES (BW)	10 Hz
	VIDEO BW (BW)	10 kHz
	THRESHOLD (DISPLAY)	OFF
	SWP TIME (SWEEP)	AUTO

CAUTION: The input to the spectrum analyzer at no time should be greater than +10 dBm (0.707 Vrms). Damage to this instrument will occur at an input level of +30 dBm (7.07 Vrms) or greater. It is recommended to monitor the audio on the analyzer display at all times during this test - especially when increasing the AF Gain Control or decreasing the variable attenuators.

5.16.3.2 Slowly increase the AF Gain control of the DUT. Receiver hiss should be heard. Adjust the volume to the desired level. Be careful not to exceed the –10 dBm reference limit on the analyzer display. Allow all equipment at least 10 minutes warm-up time before proceeding to step 5.16.3.3.

5.16.3.3 Adjust the #1 Generator RF LEVEL control until the signal is just heard in the receiver. Adjust the INPUT RANGE and receiver controls as required to maintain approximately a mid-scale meter indication while carefully tuning the receiver for peak signal response on the audio level meter.

5.16.3.4 Set the #2 Generator RF switch to OFF. Peak the DUT tuning control for maximum response as indicated by the audio level meter.

5.16.3.5A If the DUT AGC is OFF, adjust the #1 RF generator for a level approximately 10 dB below the 1-dB compression point. Recheck the receiver tuning for peak response on the Distortion Meter. The audio output frequency should be approximately 500 to 1,000 Hz. If necessary, adjust the receiver tuning to bring the output audio into this range while maintaining a peak response on the meter as best as is possible.

5.16.3.5B If the DUT AGC is set to Fast, increase the #1 RF generator for approximately an S-9 indication on the DUT S-Meter. (The input signal to the DUT should be approximately 50  $\mu$ V.) Recheck the receiver tuning for peak response on the Distortion Meter. The audio output frequency should be approximately 500 to 1,000 Hz. Adjust, if necessary, the receiver tuning to bring the output audio into this range while maintaining a peak response on the meter as best as is possible.

5.16.3.6 Adjust the Distortion Analyzer INPUT LEVEL and RELATIVE ADJUST Controls for a meter reading of –1 dB. Turn on the notch filter and observe any change in the meter indication. Adjust the notch filter for the minimum meter reading *change* between Notch Filter On and Off. Record the difference between the –1 dB reference and the meter reading in 5.16.3.6 of the Data Sheet. Return the notch filter adjustment to its upper or lower limit.

5.16.3.7 Observe the receiver's output audio on the spectrum analyzer. The scan rate may be increased temporarily by adjusting the SWP TIME (SWEEP) control. (NOTE: The analyzer will not be in calibration if the scan rate is increased beyond the point MEAS UNCAL appears on the display.) Adjust the attenuators and DUT AF Gain control for an indication of –10 dB on the spectrum analyzer.

5.16.3.8 Set the #2 RF Generator RF switch to ON. A second tone that is 1,200 Hz greater in pitch should be heard in the receiver output. Adjust the Spectrum Analyzer CENTER FREQ (FREQUENCY) Control for this second tone to appear right on the display vertical centerline. Adjust the #2 RF Generator RF LEVEL Control for the second pip to be equal to the first pip. (The first pip should now be visible just over two divisions to the left of the display centerline.)

5.16.3.9 If necessary, slow the scan rate down to a point where the analyzer is again in calibration. Adjust the spectrum analyzer input step attenuator for the two pips to be at the -10 dBm reference (top) line of the spectrum analyzer display. Re-adjust, if necessary, the #2 RF Generator RF LEVEL Control if the two tones are no longer equal in amplitude.

5.16.3.10 Set the #1 RF Generator RF switch to OFF. Adjust the notch filter for the best null of the remaining higher pitched tone. Both the ear and the spectrum analyzer display may be used to determine the point of best null. The scan rate may again be temporarily increased to facilitate this adjustment. Be sure to slow it down so that the display is once again calibrated before proceeding to the next step.

5.16.3.11 Set the #1 Signal Generator RF Switch to ON. Adjust, if necessary, the Step Attenuators and DUT AF GAIN Control for the #1 Generator tone for the -10 dBm reference on the display. The notched #2 Generator tone should now be on the vertical centerline. The notch depth may now be read directly on the display. A single sweep may now be taken to facilitate this measurement by depressing the SGL SWEEP Button. Record in 5.16.3.11 of the Data Sheet.

5.16.3.12 Repeat for all other available DSP, IF and AF notch filters and notch filter combinations. Also try the following combinations:

2 tones (S9 each), AGC on, manual notch	2 tones (S9 + S1), AGC on, manual notch
1 tone, AGC on, manual notch	1 tone, AGC off, manual notch
1 tone, AGC on, auto notch	1 tone, AGC off, auto notch

Note changes in tone level and noise level. Also note changes in S-meter for AGC on tests.

*Auto-Notch Attack Time: Proceed only if DUT has DSP Auto-Notch Feature*

5.16.3.13 With all power switches in the OFF position and the transceiver in the receive mode, connect the following:

<u>Connection</u>	<u>Connectors</u>	<u>Cable Type</u>
Signal Gen Output to 10-dB step INPUT	Type N to BNC	50-Ohm coax
10-dB step Attn OUT to 1-dB step IN	BNC to BNC	50-Ohm coax
1-dB step Attn IN to DUT RF Input	BNC to Type N	50-Ohm coax
Signal Gen Output to Scope CH1 INPUT	BNC clip to BNC	50-Ohm coax
DUT Audio Output to Scope CH2 INPUT	As Required to BNC	50-Ohm coax
DUT Audio Output to 8 Ohm Load	As Required to BNC	50-Ohm coax

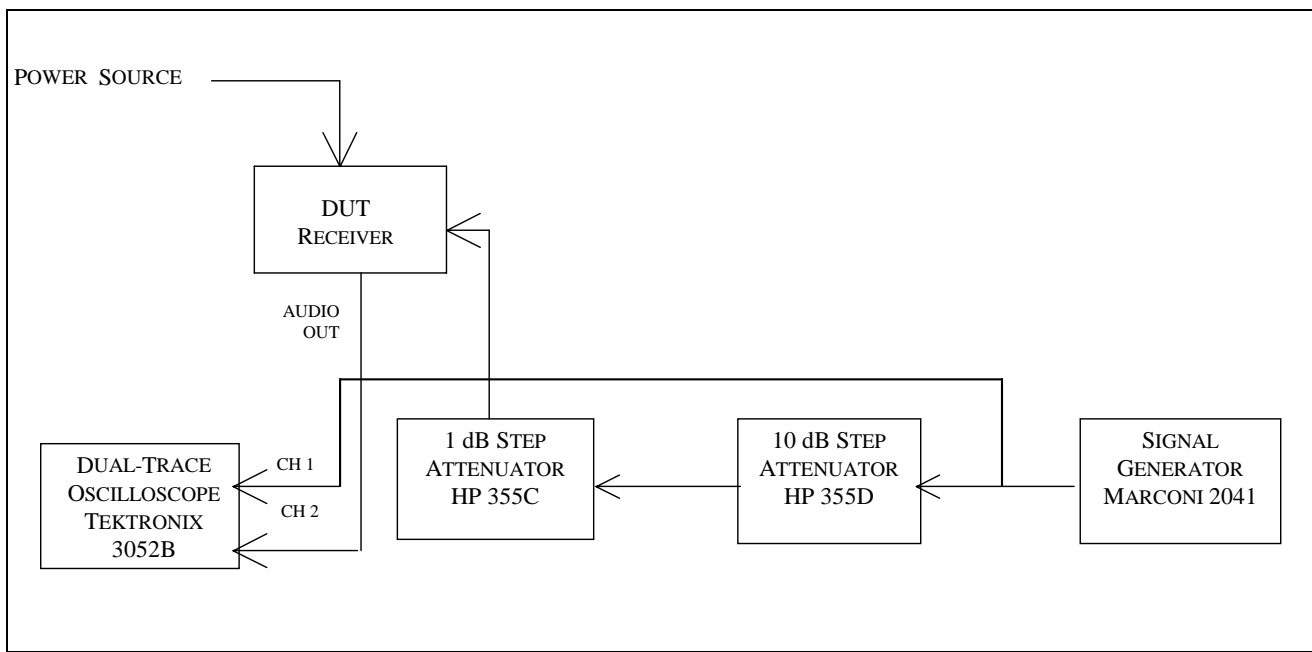

Fig. 5-16A — Notch Attack Time Test Hook-up

5.16.3.14 Turn the DUT and test equipment power switches to ON. Set the following controls:

<u>Instrument</u>	<u>Control</u>	<u>Position</u>
DUT	Mode	USB
	Band Selector	20 Meters
	Frequency	14.200 MHz
	XMIT/RCV	Receive
	DRIVE or RF LEVEL	Minimum
	AGC	OFF
RF Generator	FREQUENCY TUNE	14.200 MHz
	OUT LEVEL	-63 dBm
	RF	ON
	AM	OFF
	FM	OFF
10-dB Step Attn	Attenuator	10 dB
1-dB Step Attn	Attenuator	0 dB
Oscilloscope	CH1 VOLTS/DIV	0.5 V
	CH1 Coupling	DC
	CH1 Position	As Needed
	CH2 VOLTS/DIV	1 V
	CH2 Coupling	DC
	CH2 Position	As Needed
	TIME/DIV	5 ms
	TRIG MODE	AUTO
	Trigger Coupling	DC
	Trigger Source	CH1
Trigger Level	as required	

5.16.3.15 Set the Signal Generator RF to ON. Tune the DUT for peak response. Set the DUT AF Gain control for comfortable listening level and adjust CH1 and CH2 VOLTS/DIV for suitable display similar to Figure 5.16B. Set the Signal Generator RF to OFF.

5.16.3.16 Place the oscilloscope into the single sweep storage mode and clear the display. Key the Signal Generator by pressing the RF to button to ON. Repeat and adjust the trigger level until a single sweep occurs every time the generator is keyed.

5.16.3.17 Measure the time delay for from the point the signal appears until it is notched by at least 50%. The oscilloscope sweep rate may be adjusted as required to facilitate this measurement. Make several sweeps and compare results. Record on data sheet.

## 5.17: Noise Figure & Equivalent Rectangular Bandwidth

This is an automated test procedure.

Hook-up:

Audio Output to HP3561 Input  
Signal Generator set to 14.020 MHz  
Set level to -94 dBm

Turn on HP-3551

CVI File, open, project  
Up folder  
FFT plot  
ffplot.prg  
load (green arrow)  
Set Analyzer to one minute sweep  
Single sweep

On the computer, pick points where the edges and the tops meet. Ex: 350 and 845 Hz.  
Calculate EqivRBW button (502 HZ)

## 5.18 Noise Figure Calculation:

Theory:

Resistor noise is -174 dBm/Hz at room temperature  
500 Hz is 27 dB away from 1 Hz  
Thus, an ideal receiver's noise figure would be:  
 $-174 \text{ dBm/Hz} + 27 \text{ dB} = -147 \text{ dBm}$

Noise Figure of the receiver = 147 dBm – dBm of MDS at 20M  
Ex: MDS at 20 meters, preamp off = -129.5 dBm  
 $\text{NF} = 147 - 129.5 \text{ dBm} = 17.5 \text{ dB}$

Calculate the Noise Figure for Preamp off, P1 and P2 if available

## VI. NON-STANDARD AND SPECIAL PURPOSE TESTS

Chapter 6 contains five non-standard and special purpose tests. These include tests for mobile radios, 9600 baud packet and obsolete tests dropped from the standard test list.

## 6.1 LOW VOLTAGE AND TEMPERATURE CHAMBER TEST

6.1.1 The purpose of the Low Voltage and Temperature Chamber Test is to determine the functionality of the mobile type DUT Transceivers at low voltage and its specified temperature limits. The temperatures and voltage used for this test are intended to simulate worst case mobile conditions within the manufacturer's specified limits. Three parameters are checked at each test point, receiver sensitivity, transmit frequency accuracy and RF power output.

6.1.2 Test hook-up (See Fig. 6-1)

6.1.2.1 With all test equipment and DUT power switches in the OFF position and the transceiver in the receive mode, set the DUT in the temperature chamber. Connect the following cables to the DUT and route them through the cable port to the specified termination at the opposite end:

<u>Connection</u>	<u>Connectors</u>	<u>Cable Type</u>
DUT RF OUTPUT to Wattmeter INPUT	As Required to Type N	50-Ohm Coax
Wattmeter OUTPUT to RF Power Attn	Type N to Type N	50-Ohm Coax
RF-Power Attenuator Output to Step Attenuator Input	BNC to BNC	50-Ohm Coax
Step Attenuator Output to Frequency Counter Input	BNC to BNC	50-Ohm Coax
Telegraph Key to DUT KEY INPUT	As Required	As Required
DUT AUDIO OUTPUT to Dist/Audio Meter Input	As Required	Double Banana
8-Ohm Load /HI-Z Amp Across Dist/Audio Meter Input	As Required	As Required
DC Power Only	As Required	As Required
1)	Variable DC Power supply to AC source.	
2)	Set power supply to specified voltage and connect to DUT.	

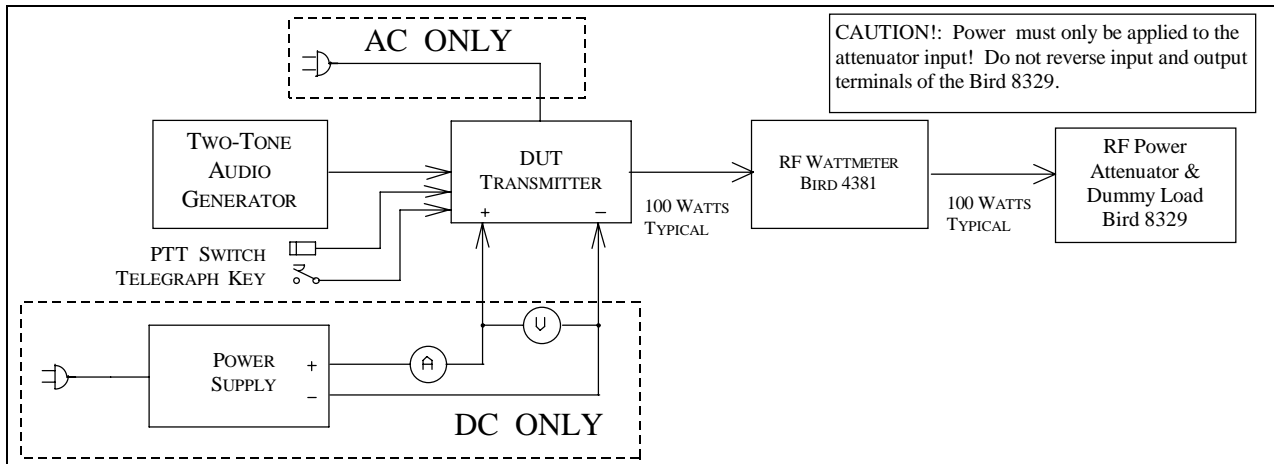

Fig. 6-1 — Chamber Test Hook-up

### 6.1.3 Test Procedure

6.1.3.1 Turn the DUT and RF wattmeter power switches to ON and set the following controls:

<u>Instrument</u>	<u>Control</u>	<u>Position</u>
DUT	Mode	CW
	Band Selector	20 Meters
	Frequency	14.020 MHz
	XMIT/RCV	RCV
	DRIVE or RF LEVEL	Minimum
	IF Filters	500 Hz or Closest Available
	AGC	OFF
Preamplifier	OFF	
RF Generator	CARRIER FREQ	14.020 MHz
	RF LEVEL	-110 dBm
	CARR ON-OFF	ON
	AM	Off
	FM	Off
NOISE MODE	LOW NOISE	
RF Wattmeter	Push Button mode select	FWD CW
	Element	As Required
	Forward Element Range	As Required
Step Attn	Attenuator	10 dB
Audio/Distortion Meter	FUNCTION	REL LEVEL
	RELATIVE ADJUST	Center Rotation
	FILTERS	All Off (Out)
	INPUT RANGE	30 V
	INPUT/GND SELECT	DIS (Center)
METER RESPONSE	NORM	

6.1.3.2 Receiver hiss should be heard; adjust volume to desired level. Allow all equipment at least 10 minutes warm-up time before proceeding to step 6.1.3.3

6.1.3.3 Tune the DUT per the DUT operators manual. Put the DUT in the CW mode Depress telegraph key. Observe that some minimum level of RF power is shown by the DUT Po Meter and Bird Wattmeter. Increase the RF DRIVE/LEVEL control if necessary to the maximum rated power.

6.1.3.4 Adjust the step attenuators for an indication on the Frequency Counter. Record both the power output and the frequency counter indication in 6.1.3.4 of the Data Sheet.

6.1.3.5 Remove the DUT RF Cable from the Power Wattmeter and connect to the Signal Generator Output. Perform an MDS Test and record results on Data Sheet.

6.1.3.5 Reduce the Power Supply voltage to 11.5 V dc. Repeat steps 6.1.3.4 and 6.1.3.5 at this reduced voltage. Return the power supply to voltage to initial setting.

6.1.3.6 Record initial chamber / ambient room temperature. Set chamber for minimum specified temperature. (NOTE: If temperature is not specified, use -10 C.) Once the chamber reaches minimum temperature, let DUT reach thermal equilibrium for at least 1 hour. Repeat steps 6.1.3.4 and 6.1.3.5. Temporarily open chamber and check functionality of several randomly selected main DUT controls.

6.1.3.7 Set chamber for maximum specified temperature. (NOTE: If temperature is not specified, use +60 C.) Once the chamber reaches maximum temperature, let DUT reach thermal equilibrium for at least 1 hour. Repeat the steps of 6.1.3.4 and 6.1.3.5. Temporarily open chamber and check functionality of several randomly selected main DUT controls.

6.1.3.8 Set chamber for initial recorded ambient temperature. Once the chamber reaches initial temperature, let DUT reach thermal equilibrium for at least 1 hour. Repeat steps 6.1.3.4 and 6.1.3.5. Open chamber and check functionality of several randomly selected main DUT controls.

6.1.3.9 Record on data sheet any significant problems or lack of functionality during any of the test points.

## 6.2 DSP NOISE REDUCTION TEST

6.2.1 The purpose of this test is to determine the level of noise reduction possible with receivers equipped with DSP. An uninterrupted unmodulated CW will be mixed with noise and fed to the DUT RF input. The audio output will be observed on the spectrum analyzer. Noise level comparisons will be made with the DSP Noise Reduction on and off..

6.2.2 Test Hook-up (See FIGURE 6-2)

Note: If proceeding from the previous test, only the hook-up changes shown with a dotted line are required.

6.2.2.1 With all power switches in the OFF position, the transmitter function disabled to the fullest extent possible and each Generator RF OFF, connect the following:

<u>Connection</u>	<u>Connectors</u>	<u>Cable Type</u>
Signal Gen Output to Hybrid Combiner INPUT	BNC to BNC	50-Ohm Coax
Elecraft Noise Gen Output to 10-dB Step Attn Input	BNC to BNC	50-Ohm Coax
10-dB Step Attn Output to 1-dB Step Attn Input	BNC to BNC	50 Ohm Coax
1-dB Step Attn Output to Hybrid Combiner Input	BNC to As Req.	50 Ohm Coax

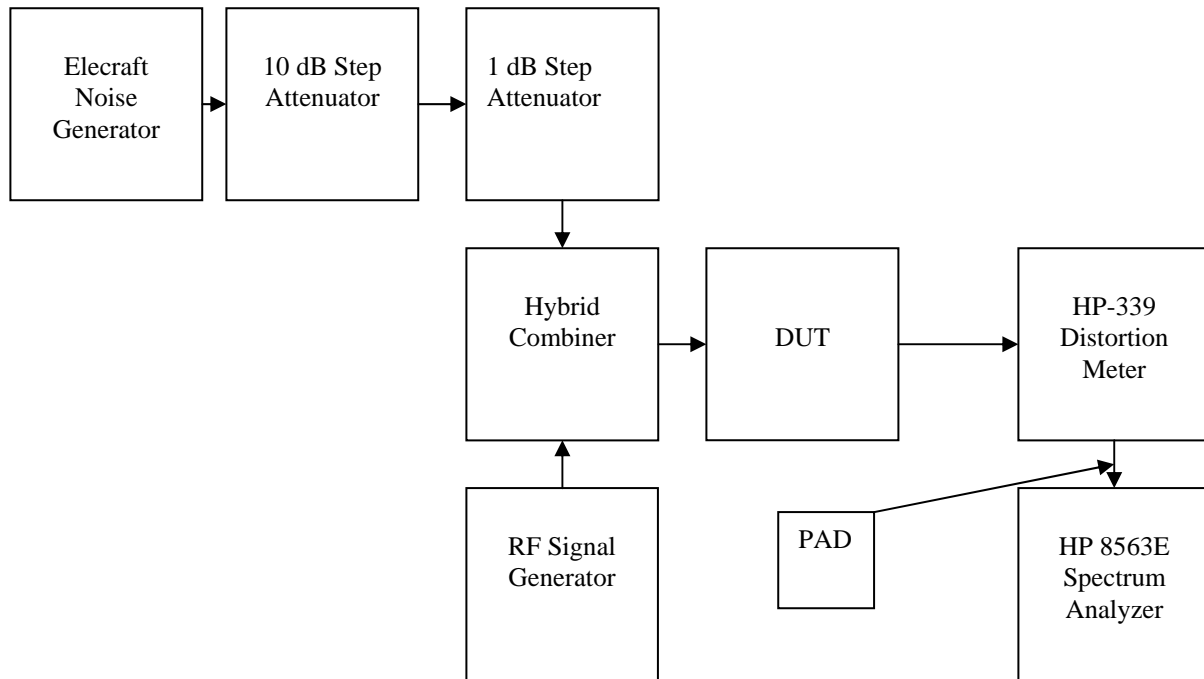

Connection

	<u>Connectors</u>	<u>Cable Type</u>
8 Ohm Load / HI-Z Amp across DUT Audio OUT	As Req.	As Req.
DUT Audio Output to Audio Attn Pad Input	As Req. to BNC	50-Ohm Coax
Audio Attn Pad Output to Spectrum Analyzer Input	BNC to BNC	Coax
Power Source to DUT Power Input	As Req.	As Req.

6.2.3 Test Procedure

6.2.3.1 Turn the DUT and all test equipment power switches to ON. Set the following controls:

<u>Instrument</u>	<u>Control</u>	<u>Position</u>
DUT	Mode	USB
	Band Selector	20 Meters
	Frequency	14.200 MHz
	XMIT/RCV	RCV
	DRIVE or RF LEVEL	Minimum
	IF Filters	SSB Widest Available
	Any Audio Filtering	Disabled
	AGC	OFF
	AF Gain (Volume Control)	Minimum

10-dB Step Attn	Attenuator	10 dB
1-dB Step Attn	Attenuator	0 dB
RF Generator	CARRIER FREQ	14.2000 MHz
	RF LEVEL	-63 dBm
	CARRIER ON-OFF	OFF
	AM	OFF
	FM	OFF
	NOISE MODE (UTIL)	LOW NOISE
Spectrum Analyzer	START FREQ - STOP FREQ	0 - 5 kHz
	REF LEV (AMPLITUDE)	-10 dBm
	ATTEN (AMPLITUDE)	20 dB
	RES (BW)	10 Hz
	VIDEO BW (BW)	10 kHz
	THRESHOLD (DISPLAY)	-80 dBm
	SWP TIME (SWEEP)	AUTO (1.3 s)

CAUTION: The input to the spectrum analyzer at no time should be greater than +10 dBm (0.707 Vrms). Damage to this instrument will occur at an input level of +30 dBm (7.07 Vrms) or greater. It is recommended to monitor the audio on the analyzer display at all times during this test - especially when increasing the AF Gain Control or decreasing the variable attenuators.<sup>1</sup>

6.2.3.2 Slowly increase the AF Gain control of the DUT. Receiver hiss should be heard. Adjust the volume to the desired level. Be careful not to exceed the -10 dBm reference limit on the analyzer display. Allow all equipment at least 10 minutes warm-up time before proceeding to step 6.2.3.3.

6.2.3.3 Increase the Generator RF LEVEL control until the signal is just heard in the receiver. Adjust the INPUT RANGE and receiver controls as required to maintain approximately a midscale meter indication while carefully tuning the receiver for peak signal response on the Audio meter.

6.2.3.4 Increase the RF generator output for approximately an S-9 indication on the DUT S-Meter. (The input signal to the DUT should be approximately 50  $\mu$ V.) Recheck the receiver tuning for peak response on the Distortion Meter. Turn on the Noise Source and adjust for approximately a 3 dB increase as indicated by the meter.

6.2.3.5 Adjust the Distortion Analyzer INPUT LEVEL and RELATIVE ADJUST Controls for a meter reading of -6 dB. Turn on the DSP Noise Reduction and observe any change in the meter indication. Adjust the Noise Reduction for best results as determined by ear and note the meter indication. Record the best case increase or decrease in 6.2.3.5 of the Data Sheet.

6.2.3.6 Vary the signal level, noise level and DSP Noise Reduction Level for the best case. Record results on data sheet.

6.2.3.7 Turn off the DSP Noise Reduction and Noise Source. Observe the receiver's output audio on the spectrum analyzer. The scan rate may be increased temporarily by adjusting the SWP TIME (SWEEP) control. (NOTE: The analyzer will not be in calibration if the scan rate is increased beyond the point MEAS UNCAL appears on the display.) Adjust the attenuators and DUT AF Gain control for an indication of -10 dB (top line) on the spectrum analyzer.

6.2.3.8 Set the DSP Noise Reduction to ON. Observe any change in the tone as shown by the spectrum analyzer. Readjust, if necessary the decrease in the DUT AF Gain Control for the -10 dB reference on the spectrum analyzer. Turn on the Noise Source and adjust so that the noise floor is 20 dB below the single tone reference. Readjust the AF Gain control if necessary for the -10 dB reference.

<sup>1</sup> "Woe be unto he who breaks this thing." ---- Edward F. Hare, W1RFI

**6.3 RECEIVER BIT ERROR RATE (BER) TEST,  
No longer part of our testing, but historical in nature.**

6.3.1 The purpose of the Receiver Bit Error Rate (BER) is to determine the usefulness of 9600 Baud reception at various input signal levels.

6.3.2 Test initialization and hook-up (See Fig. 6.3-1)

NOTE: The IEEE Interface Bus, BER Test Box to Computer COM 1 port and BERT software must be correctly installed before proceeding to this step.

6.3.2.1 Turn on the BER Test box, Marconi Generator and Test Computer. While in DOS, go to the C:\SROOM subdirectory. Type "BERT" and press Enter to start the initializing process. After completion of this process, type the DUT radio and model number when prompted to do so. Next, type "R" for Receiver Tests. The next prompt will be for the test frequency. Use either 146.000 MHz or 440 MHz, whichever is appropriate for the band being tested. Type "I" for Initial Connections and Set-Up when the next prompt appears. Connect the following test hook-up as prompted to do so:

<u>Connection</u>	<u>Connectors</u>	<u>Cable Type</u>
BER Test Box DSP OUTPUT to Marconi EXT MOD INPUT	BNC to BNC	50 Ohm coax
BER Test Box AUDIO IN to DUT RX Data Output	BNC to As Required	50 Ohm coax
BER Test Box AUDIO OUT to Oscilloscope CHANNEL 2 INPUT	BNC to BNC	50 Ohm coax
BER Test Box SYNC OUT to Oscilloscope CHANNEL 1 INPUT	BNC to BNC	50 Ohm coax
BER Test Box Clock Input to HP-8116A OUTPUT	BNC to BNC	50 Ohm coax
DUT RF Input to Marconi RF signal OUTPUT	As Required to BNC	50 Ohm coax

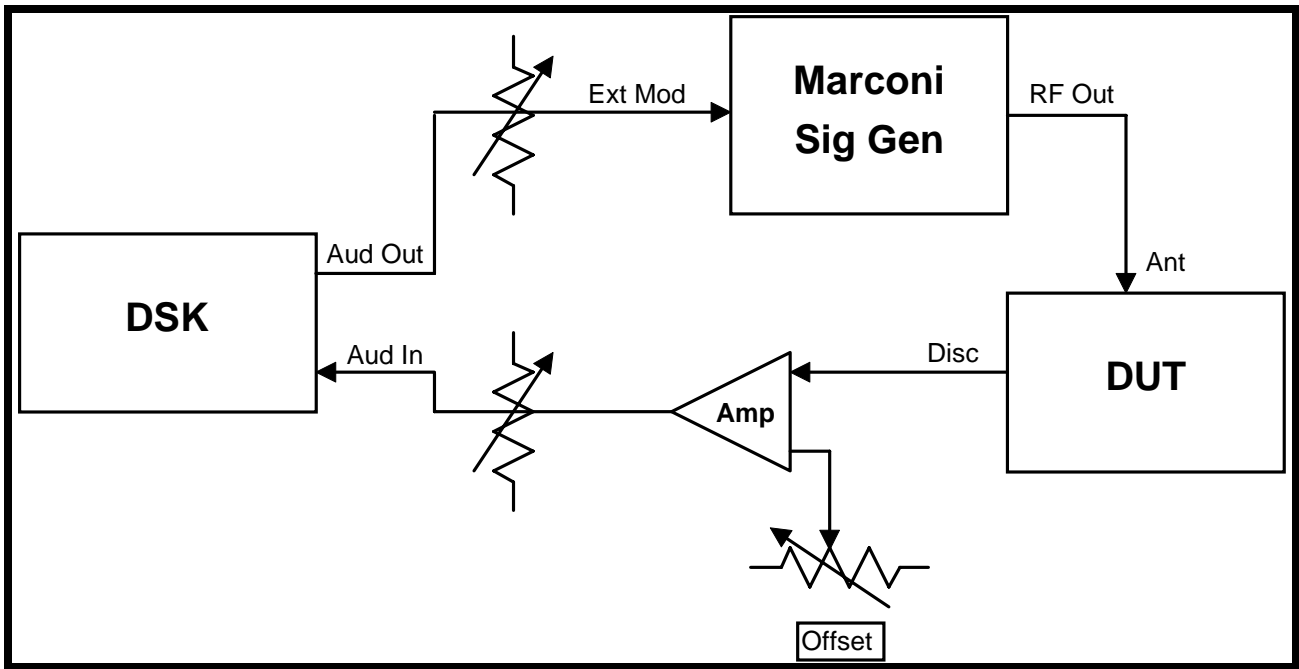

Fig. 6.3-1 — Fig 1.

### 6.3.3 Test Procedure

6.3.3.1 Turn the on the DUT and set the following controls:

<u>Instrument</u>	<u>Control</u>	<u>Position</u>
Oscilloscope	Channel 1	5 V / Div, DC
	Channel 2	0.5 V / DIV, AC
	VERT MODE	ALT
	TRIGGER	CH 1 ONLY, DC, AUTO
	HORIZONTAL TIME BASE	0.2 ms / DIV
Function Generator	Mode	Square Wave
	Amplitude	4.75 +/- 0.25 V to GND
	Frequency	500 kHz
BER Test Box	DSP OUTPUT LEVEL	Fully CW (IMPORTANT)
	SOURCE SELECT	AUDIO
	GAIN ADJUST	1.5 Vpp on 'scope
DUT	Mode	9600 Baud Data
	Band Selector	As Required
	Frequency	146 or 440 MHz
	XMIT/RCV	RCV
	DRIVE or RF LEVEL	Minimum
	IF Filters	As Req for 9600 Baud Data
	Preamplifier	OFF
RF Generator	All	Set Automatically

NOTE: Software is configured for use with the older IEEE card. However, this card has a conflict with an unknown device on the IEEE bus. Removal of all IEEE connections except the Marconi is necessary for this and the following test.

6.3.3.2 Receiver hiss should be heard; adjust volume to desired level. Allow all equipment at least 10 minutes warm-up time before proceeding to step 6.3.3.3

6.3.3.3 Type “C” for Calibrate. The calibration process requires two steps and prompts appear describing each. The first is to set two pulses for simultaneous timing. Figure 2A depicts correct trace appearance for this step. The second sets a 14 us delay as depicted by Figure 2B.

6.3.3.4 A quick check can now be made. Manually set a -50 dBm signal. Type “4” for 10,000 ( $10^4$ ) bits. If 0 or nearly 0 bit errors are detected, the system is functioning correctly. If 10,000 or nearly 10,000 errors are detected, then invert pulse. If approximately 50%, or 5,000 bit errors are detected, there is a problem with the system or test set-up. Recalibrate per step 6.3.3.3. Once 0 or nearly 0 errors are obtained, you may proceed to the next step.

6.3.3.5 Select menu option “A” for Automatic Test Sequence. (NOTE: Hook-up and calibration menus will reappear. Test will run automatically after this.)

6.3.3.6 One the automatic test sequence is completed, type “V” to save data to an appropriately named file that you select. Plots can be displayed by selecting “P” option.

6.3.3.7 Run a -50 dBm test for 1,000,000 bits. Hand record the results as part of the data.

**NOTE:** Although the automatic test sequence will generate considerable data, the published data typically only includes the BER at three test points. In order of ascending signal strength, these points are 12 dB SINAD, 16 dB SINAD and the hand recorded BER at -50 dBm. The first two data points are typically read from the data tables. **The minimum published BER is  $<1 \times 10^{-5}$ .**

## 6.4 TRANSMITTER BIT ERROR RATE (BER) TEST

**No longer tested, but historical in nature**

6.4.1 The purpose of the Transmitter Bit Error Rate (BER) Test is to determine the usefulness of 9600 Baud transmissions when received at various receive signal levels. The signal will be adjusted for two levels before being applied to the BER Test Box, 12 dB SINAD and 12 dB SINAD plus 30 dB.

6.4.2 Test initialization and hook-up (see Fig 6.4-1).

NOTE: The IEEE Interface Bus, BER Test Box to Computer COM 1 port and BERT software must be correctly installed before proceeding to this step.

6.4.2.1 Turn on the BER Test box, Marconi Generator and Test Computer. While in DOS, go to the C:\SROOM subdirectory. Type “BERT” and press Enter to start the initializing process. After completion of this process, type the DUT radio and model number when prompted to do so. Next, type “T” for Transmitter Tests. The next prompt is for the test frequency. Use either 146 MHz or 440 MHz, whichever is appropriate for the band being tested. Type “I” for Initial Connections and Set-Up when the next prompt appears. Connect the following test hook-up as prompted to do so:

<u>Connection</u>	<u>Connectors</u>	<u>Cable Type</u>
TX RF Output to Bird Power Attenuator Input	As Required to BNC	50-Ohm coax
TX Data Input to BER Test Box DSP OUTPUT	As Required to BNC	50-Ohm coax

Bird Power Attenuator Output to Manual 10 dB Step Attenuator Input	BNC to BNC	50-Ohm coax
Manual 10 dB Step Attenuator Output to HP 10 dB Step Attenuator Input	BNC to BNC	50-Ohm coax
HP 10 dB Step Attenuator Output to HP 1 dB Step Attenuator Input	BNC to BNC	50-Ohm coax
HP 1 dB Step Attenuator OUT to BER Test Box RF INPUT (“RF”)	BNC to BNC	50-Ohm coax
BER Test Box LO to Marconi RF OUT	BNC to BNC	50-Ohm coax
BER Test Box AUDIO OUT to Oscilloscope CHANNEL 2 INPUT	BNC to BNC	50-Ohm coax
BER Test Box DSP Output to DUT TX Data input	RCA to As Required	50-Ohm coax
BER Test Box SYNC OUT to Oscilloscope CHANNEL 1 INPUT	BNC to BNC	50-Ohm coax

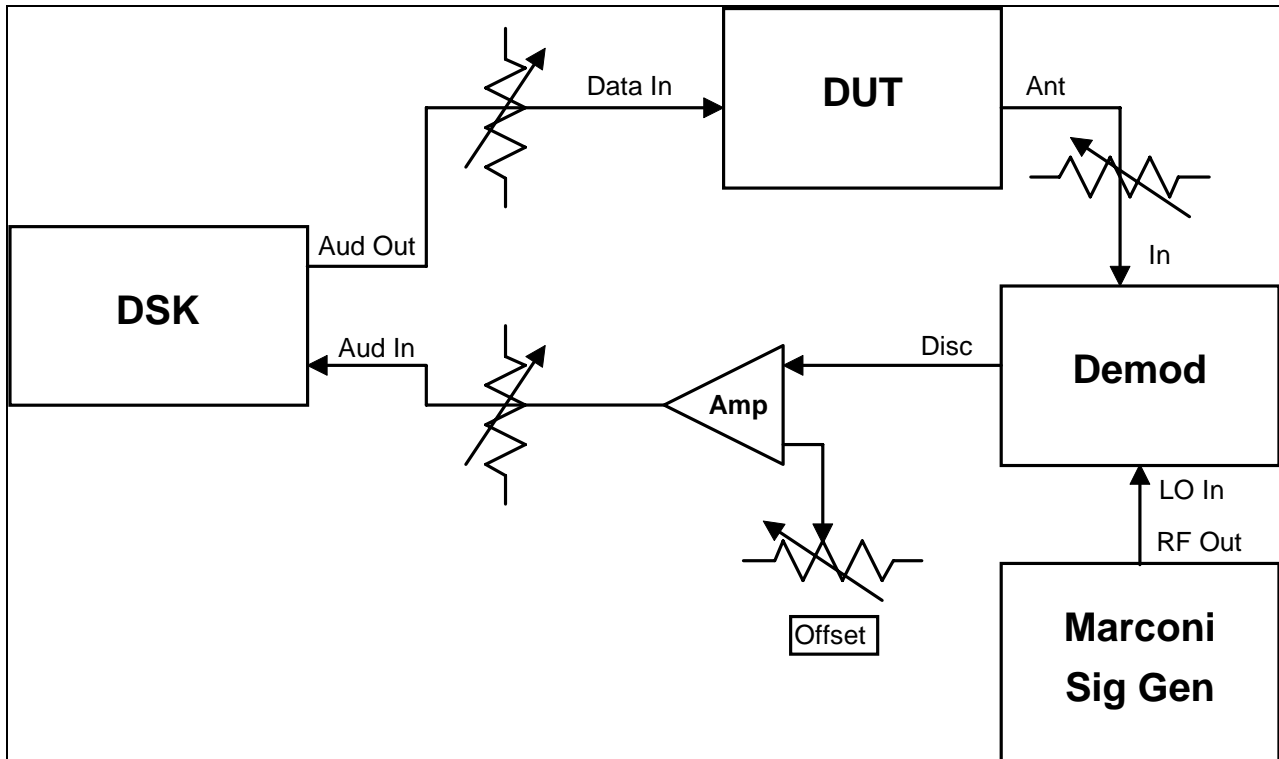

Fig. 6.4-1.

### 6.4.3 Test Procedure

6.4.3.1 Turn the on the DUT and set the following controls:

<u>Instrument</u>	<u>Control</u>	<u>Position</u>
Oscilloscope	Channel 1	5 V / Div, DC
	Channel 2	0.5 V / DIV, AC
	VERT MODE	ALT
	TRIGGER	CH 1 ONLY, DC, AUTO
	HORIZONTAL TIME BASE	0.2 ms / DIV
BER Test Box	DSP OUTPUT LEVEL	Fully CCW
	SOURCE SELECT	DEMOD
	GAIN ADJUST	Fully CCW
Manual 10 dB Step Attenuator	Attenuation	As required (see below)
DUT	Mode	9600 Baud Data
	Band Selector	As Required
	Frequency	146 or 440 MHz
	XMIT/RCV	RCV
	DRIVE or RF LEVEL	Minimum
RF Generator	All	Set Automatically

6.4.3.2 Receiver hiss should be heard; adjust volume to desired level. Allow all equipment at least 10 minutes warm-up time before proceeding to step 6.4.3.3

6.4.3.3 Set DUT Transmitter for minimum power. Set the manual step attenuator for approximately 0 dBm ( $\pm 10$  dBm) into the HP 10 dB step attenuator.

6.4.3.4 Set the BER Test Box GAIN Control to produce 1.5 Vpp as determined by the lower channel 2 trace on the oscilloscope.

6.4.3.5 Use spacebar to toggle between reference signal and DUT signal. Adjust the BER Test Box DSP OUTPUT LEVEL so that both signals are same amplitude as viewed on oscilloscope. Hit any other key to exit.

6.4.3.6 Type “C” for Calibrate. The calibration process requires two steps and prompts appear describing each. The first is to set two pulses for simultaneous timing. Figure 2A depicts correct trace appearance for this step. The second sets a 14  $\mu$ s delay as depicted by Figure 2B. Repeat the calibration process to verify the calibration.

Note: Automation of software for this test is not yet complete. Manual control and recording of all data is required. Set the software to “debug” mode (hit “Q” to back up a menu, then select Debug option). All program control is now done via the debug menus (see Table 1 for a list of commands). Hit the Esc key to exit debug mode when done.

6.4.3.7 Manually enable the Marconi carrier output and check SINAD level by typing “S”. Set attenuators for 12 dB SINAD using < and > commands. Adjust noise level output with potentiometer control on BER test box as necessary.

6.4.3.8 A quick check of the test set-up can now be made if desired. Temporarily decrease the step attenuators by 30 or 40 dB. Type “4” for 10,000 ( $10^4$ ) bits. If 0 or nearly 0 bit errors are detected, the system is functioning correctly. If 10,000 or nearly 10,000 errors are detected, then invert pulse. If approximately 50%, or 5,000 bit errors are detected, there is a problem with the system or test set-up. Recalibrate per step 6.4.3.6 and 6.4.3.7. Once 0 or nearly 0 errors are obtained, you may proceed to the next step.

6.4.3.9 Return the step attenuators for 12 dB SINAD setting. Run the test with  $1 \times 10^6$  bits by typing “6”. Manually record the resulting Bit Error Rate.

6.4.3.10 Increase the signal by 30 dB (decrease attenuators 30 dB). Again run the test with  $1 \times 10^6$  bits by typing “6”. Manually record the resulting Bit Error Rate.

**NOTE:** The published BER typically includes two data points, 12 dB SINAD and 12 dB SINAD + 30 dB. **The minimum published BER is  $1 \times 10^{-5}$ .**

NOTE: If test frequency is 440 MHz or higher, you may wish to down convert to lower frequency. Use an LO frequency of 540 MHz for 100 MHz IF.

-----  
**TABLE 1**

Transmitter BER Tests  
Use Debug mode of BERT program

**Commands**

**Esc** Exit Debug mode

<	Decrease attenuation (Shift = 10 dB)	>	Increase attenuation (Shift = 10 dB)
<b>C</b>	Generate calibration signal	<b>I</b>	Generate idle signal (second stage of calibration)
+	Adjust coarse calibration	-	Adjust coarse calibration
<b>A</b>	Adjust fine calibration		
<b>4</b>	BER $10^4$	<b>5</b>	BER $10^5$
<b>S</b>	SINAD measurement	<b>N</b>	Sine-wave idle signal
<b>1</b>	Data is inverted	<b>0</b>	Data is non-inverted
		<b>6</b>	BER $10^6$
		<b>Q</b>	Quiet (unmodulated) idle

**6.6 Power Meter Test**

6.6.1 The purpose of the power meter test is to measure power output developed by a RF transmitter by the DUT. This measurement directly compared to the HP 432B power meter and the table provided in Appendix XX.X. This table takes into account losses of attenuators and coax cables between the DUT and the HP power meter. Measurements will be recorded on Data Sheet X.XX. Also included are measurements of SWR compared against a known 1:1 and 2:1 load.

Two special RG-8 cables must be used. The dB loss of each cable have been previously measured on the frequencies used during this test. They are labeled with green tags as “Coax 1” and “Coax 2”.

An RF linear amplifier must be used along with a transceiver capable of more than 100 watts (105 -110 watts) at the frequencies used must also be located. Inspect the data sheets of each DUT to determine if 6 meters or higher frequencies are needed for your choice of transceiver and linear amplifier. Also, use a linear amplifier that runs off of the 220 volt power receptacle in the screen room.

6.6.2 Test hook-up (See FIG. 6-1)

6.6.2.1 With all test equipment and DUT power switches in the off position and the transmitter in the receive mode, connect the following:

<u>Connection</u>	<u>Connectors</u>	<u>Cable Type</u>
-------------------	-------------------	-------------------

-----

HF/VHF transceiver to Linear Amplifier	PL-259 to PL-259	50 Ohm Coax
Linear Amplifier to DUT	PL-259 to PL-259	50 Ohm Coax
DUT to Bird 8329 30 dB Attenuator	PL-259 to Type N	“Coax 1”
Bird 8329 to HP 20 dB Attenuator	Type N to Type N	“Coax 2”
HP 20 dB Attenuator to Bird 10 dB Attenuator (for high power test)	Direct Connection	
HP or Bird Attenuator to HP 432B Power Meter	Direct Connection	
DC Power supply to DUT	As Required	
Two-Tone Generator to Microphone Jack	As Required	
Telegraph Key	As Required	
Keying Generator to Transceiver Key Jack	As Required	50 Ohm Coax

Keying connection from Transceiver to Linear Amplifier

---

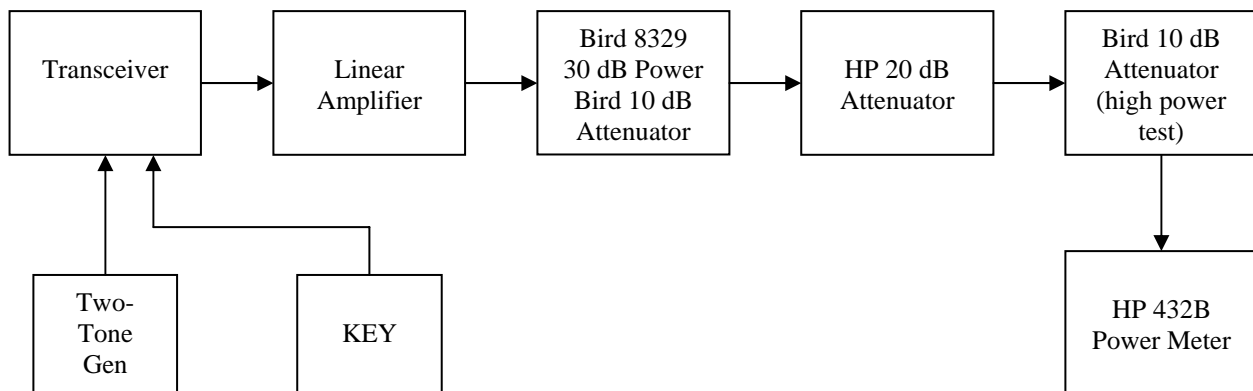

6.6.3 Test Procedure

6.6.3.1 Turn on DUT, transceiver and power meter. Turn on DC supply for DUT. Leave the linear amplifier off until doing the high power tests.

6.6.3.2 Calibrate the HP 432B Power Meter. Make sure the frequency and calibration factor is correct for each individual test. Consult the power meter manual if needed.

<u>Instrument</u>	<u>Control</u>	<u>Position</u>
Transceiver	Power Output	Lowest Setting
	Frequency	1.995 Mhz
	Antenna Port	As Required
	Mode	CW
	Mic Gain	Lowest Setting
Linear Amplifier	AC Power	Off
HP Power Meter	Frequency	.002 Ghz
	Calibration Factor	See Table XX.X
	Zero	As Required
	dBm/mW	mW
DUT	RANGE	200 or "Mid"
	AVE/PEP	AVE.
	DC Power	ON
	HOLD	Mid Scale

6.6.3.3 Allow all equipment to warm up at least 10 minutes before proceeding to step 6.1.3.4

6.6.3.4 Tune the transceiver per the operators manual. Put the transceiver in the CW transmit mode. Depress the telegraph key. Slowly turn up the power until a reading of XX.X mW is read on the power meter, equivalent to 100 watts at the DUT. If this reading cannot be attained, get to as close to XX.X as possible as possible. Note the difference, if any. Transmitting as long as necessary to get a steady reading on the HP power meter, at least 15 seconds. Let go of the telegraph key to turn off transmit mode.

6.6.3.5 Read DUT meter. Add or subtract power from this reading if an exact level could not be attained on the HP 432B power meter with step 6.1.3.4. Example:

HP 432B reads .925 mW but should read .930 mW. The DUT meter should be reading approximately 0.5 lower than it should be when applied 100 watts. Add a half of a watt for this example. In reality, the difference should be multiplied by the percentage of power reaching the HP power meter, in this case, 0.5 watts X 0.930 = 0.465 watts. This may not make much difference on the 5 and 100 watt tests (especially with analog power meters), but does on the 1000 watt tests.

6.6.3.6 Remove telegraph key from the transceiver. Plug in Keying Generator. Adjust the keying generator for its highest speed. This gives the 50% duty cycle required. Turn generator on. Without adjusting the power output from the previous step, note the power reading on the DUT in the AVE and also in the PEP mode. (add any correction if necessary as in step 6.1.3.5). Record on Data Sheet.

6.6.3.7 Repeat the above steps for the 5 watt level tests. Set the DUT to the lowest power range. Please note the table for the HP432B at this level. Record results of the AVE and PEP and 50 % duty cycle power as in steps 6.1.3.4 through 6.1.3.6 in on Data Sheet.

6.6.3.8 Place transceiver on 14 Mhz, Replace the keying generator with the telegraph key. Adjust power until the desired level is reached on the HP power meter for 100 watts at the DUT. Do not forget to adjust the HP power meter for the proper calibration factor and frequency. Zero before making all measurements. Record the AVE and PEP on the Data Sheet. Repeat for 5 watt measurements as in steps 6.1.3.4 through 3.1.3.6.

6.6.3.81 Repeat the above steps for 28, 50, 144, 222, & 432 Mhz, if necessary.

6.6.3.9 Remove the telegraph key. Plug in the two-tone generator to the transceiver's microphone jack. Place the transceiver in the USB mode and turn on the VOX. Turn on the generator, both tones on. Turn up the mic gain on the transceiver and note the ALC. Adjust gain so the ALC is one quarter scale. Put the DUT to PEP. Note the power on the DUT and record it on the Data Sheet. Turn off tone generator.

\*\*\*\*NOTE: Before the two-tone reading can be made, the two tones of the generator must be exactly even. Use the HP 8563E Spectrum Analyzer with the proper attenuators and step attenuators to match the tones evenly. Adjust the "Balance" control on the tone generator to match the tones on the analyzer. \*\*\*\*

6.6.3.10 Turn the AC power "on" on the Linear Amplifier. Place the amplifier in "standby" Allow to warm up at least 10 minutes. Set the Linear Amplifier and Transceiver for the 160 Meter band, the transceiver frequency adjusted to 1.995 Mhz.

6.6.3.11 Place the 10 dB Bird Attenuator in series with the HP 20 dB attenuator. The is now a total of over 50 dB of attenuation for the input of the HP 432B power meter. Please note the set of tables for this extra attenuator for the 1000 watt measurements.

6.6.3.12 Set the transceiver for the lowest power output. Set the DUT to the highest power range. Place the telegraph key in the transceiver. Make sure the transceiver is in the CW mode. Place the Linear Amplifier in the "operate" position. Key the transmitter and slowly adjust the power output of the transceiver. Match the HP power meter to the table provided for 1000 watts at the DUT. Record the AVE and PEP power read by the DUT on the Data Sheet. Let go of the key ! Repeat the above steps for 50 % duty cycle, two-tone (14 Mhz only) for 14 and 28 Mhz. (At this time, we do not have linear amplifiers for VHF and UHF testing.) Is it getting hot in there or what ?

Note: Keep an eye on the Linear Amplifier and Transceivers heat dissipation. Let them cool down if necessary.

## SWR TEST

For this test, only the transceiver is used. Make certain the Linear Amplifier AC power is "off". The test is preformed at the 100 watt level. Only the 30 dB Bird 8329 Attenuator is needed and used as a 1:1 load. Two 50 ohm precision carbon resistors in parallel will be used as a 2:1 load. "Coax 1" cable is used between the DUT and the 1:1 load. The 2:1 is connected directly to the DUT via its 6 inch long coax cable. Care must be used to keep the 2:1 load away from on top of or near conductive surfaces.

6.6.3.13 With the linear amplifier AC power off, set the power meter to “MID” or the 200 watt range. Connect the DUT antenna connector to the 1:1 load. Set the frequency of the transceiver to 1.995 Mhz. Set the power output of the transceiver to the lowest output setting. Place the transceiver in CW transmit mode and depress the key. Adjust the power output while watching the DUT. Adjust the transceiver for 100 watts on the DUT. Read the SWR and record on the Data Sheet. Release the key ! Repeat for 14, 28, 50 Mhz, if necessary.

There are two kinds of SWR measuring meters, cross needle and single needle. Cross needle meters are read directly, single meters employ a “SET” knob and a forward/ reflected switch. If using a single needle SWR meter, rotate the set knob to full scale in the “forward” position while transmitting. Keep transmitting and switch to “reflected” to read the SWR.

6.6.3.14 Plug in the 2:1 load to the DUT antenna connector to the 2:1 load. Repeat step 6.6.3.13 and record on the data sheet.

## **VII. DATA SHEETS/ PRODUCT REVIEW TEST MANUAL**

Manufacturer: \_\_\_\_\_ Model: \_\_\_\_\_ Serial #: \_\_\_\_\_

Date: \_\_\_\_\_ Test Engineer: \_\_\_\_\_

**4.0 TRANSMITTER TESTS**

**4.1 OUTPUT-POWER TEST**

**4.1.3.5** DC Power Supply Only/ Maximum Output Power:  
 Voltmeter Reading: \_\_\_\_\_ V      Ammeter Reading: \_\_\_\_\_ A

**4.1.3.6** Receive Current:  
 Maximum volume; no signal; lights default: \_\_\_\_\_ mA

**4.1.3.7 to 4.1.3.9; 4.1.3.11 to 4.1.3.13**

Band	Mode	DUT Min	Bird Min	DUT Max	Bird Max	Spurs/ Notes
160	CW	_____	_____	_____	_____	_____
80	CW	_____	_____	_____	_____	_____
	AM	_____	_____	_____	_____	_____
60	SSB	_____	_____	_____	_____	_____
40	CW	_____	_____	_____	_____	_____
30	CW	_____	_____	_____	_____	_____
20	CW	_____	_____	_____	_____	_____
	SSB	_____	_____	_____	_____	_____
17	CW	_____	_____	_____	_____	_____
15	CW	_____	_____	_____	_____	_____
12	CW	_____	_____	_____	_____	_____
10	CW	_____	_____	_____	_____	_____
	FM	_____	_____	_____	_____	_____
6	CW	_____	_____	_____	_____	_____
	SSB	_____	_____	_____	_____	_____
	FM	_____	_____	_____	_____	_____
	AM	_____	_____	_____	_____	_____

2	CW	_____	_____	_____	_____	_____
	SSB	_____	_____	_____	_____	_____
	FM	_____	_____	_____	_____	_____
	AM	_____	_____	_____	_____	_____
440	CW	_____	_____	_____	_____	_____
	SSB	_____	_____	_____	_____	_____
	FM	_____	_____	_____	_____	_____
	AM	_____	_____	_____	_____	_____

**4.1.3.14** Transverter Output

Band	µWattmeter Max
20	_____
15	_____
10	_____

**4.2 TRANSMIT FREQUENCY RANGE TEST**

	Band	Low Frequency Limit	High Frequency Limit
<b>4.2.3.4/</b>	160	_____ MHz	_____ MHz
<b>4.2.3.5</b>			
<b>4.2.3.6</b>	80	_____ MHz	_____ MHz
	60	_____ MHz	_____ MHz
	40	_____ MHz	_____ MHz
	30	_____ MHz	_____ MHz
	20	_____ MHz	_____ MHz
	17	_____ MHz	_____ MHz
	15	_____ MHz	_____ MHz
	12	_____ MHz	_____ MHz
	10	_____ MHz	_____ MHz
	6	_____ MHz	_____ MHz
	2	_____ MHz	_____ MHz
	440	_____ MHz	_____ MHz

All frequencies as measured on transmitter dial read-out.

**4.3 CW TRANSMIT-FREQUENCY ACCURACY TEST**

**Note:** See 6.1 Low-Voltage and Temperature Chamber Test for units designed for mobile and/or portable use.

**4.3.3.3** 20M Unkeyed DUT Frequency: \_\_\_\_\_ MHz

**4.3.3.5/** 20M Max Power Out/ Counter Display: \_\_\_\_\_ MHz

**4.3.3.6**

**4.3.3.4/** No significant display variation due to change in DC input

**4.3.3.7** power (12V min) or Power Output ( ).

**4.3.3.8** 6M Unkeyed DUT Frequency: \_\_\_\_\_ MHz  
 Max Power Out/ Counter Display: \_\_\_\_\_ MHz

No significant display variation due to change in DC input power or Power Output ( ).

2M Unkeyed DUT Frequency: \_\_\_\_\_ MHz  
 Max Power Out/ Counter Display: \_\_\_\_\_ MHz

No significant display variation due to change in DC input power or Power Output ( ).

440MHz Unkeyed DUT Frequency: \_\_\_\_\_ MHz  
 Max Power Out/ Counter Display: \_\_\_\_\_ MHz

No significant display variation due to change in DC input power or Power Output ( ).

**4.4 SPECTRAL PURITY TEST**

	Band	Spur @ Max Power	Note	Spur Check @ Min Power	Note
<b>4.4.3.9/</b>	160	_____ dBc	_____	_____ dBc	_____
<b>4.4.3.10</b>					
<b>4.4.3.11</b>	80	_____ dBc	_____	_____ dBc	_____
	60	_____ dBc	_____	_____ dBc	_____
	40	_____ dBc	_____	_____ dBc	_____
	30	_____ dBc	_____	_____ dBc	_____
	20	_____ dBc	_____	_____ dBc	_____
	17	_____ dBc	_____	_____ dBc	_____
	15	_____ dBc	_____	_____ dBc	_____
	12	_____ dBc	_____	_____ dBc	_____
	10	_____ dBc	_____	_____ dBc	_____
	6	_____ dBc	_____	_____ dBc	_____
	2	_____ dBc	_____	_____ dBc	_____
	440	_____ dBc	_____	_____ dBc	_____

\*NOTE: 5W minimum power.

**4.4.3.12** PLOT - WORST CASE/ SPECTRAL PURITY TAKEN ( )

DUT FREQUENCY \_\_\_\_\_ MHz      SPUR LEVEL \_\_\_\_\_ dBc

**4.4.3.13** DUT Meets FCC Specifications: \_\_\_\_\_ YES \_\_\_\_\_ NO

**4.5 TWO-TONE TRANSMIT IMD TEST**

100W PEP  
ac Volt.

- 4.5.3.7 3.900 MHz - TWO-TONE TRANSMIT IMD 3<sup>rd</sup>/5<sup>th</sup> ( / ) \_\_\_\_\_
- 4.5.3.8 14.250 MHz - TWO-TONE TRANSMIT IMD 3<sup>rd</sup>/5<sup>th</sup> ( / ) \_\_\_\_\_
- 4.5.3.9 1.850 MHz - TWO-TONE TRANSMIT IMD 3<sup>rd</sup>/5<sup>th</sup> ( / ) \_\_\_\_\_  
5.330 MHz - TWO-TONE TRANSMIT IMD 3<sup>rd</sup>/5<sup>th</sup> ( / ) \_\_\_\_\_  
7.250 MHz - TWO-TONE TRANSMIT IMD 3<sup>rd</sup>/5<sup>th</sup> ( / ) \_\_\_\_\_  
10.120 MHz - TWO-TONE TRANSMIT IMD 3<sup>rd</sup>/5<sup>th</sup> ( / ) \_\_\_\_\_  
18.120 MHz - TWO-TONE TRANSMIT IMD 3<sup>rd</sup>/5<sup>th</sup> ( / ) \_\_\_\_\_  
21.250 MHz - TWO-TONE TRANSMIT IMD 3<sup>rd</sup>/5<sup>th</sup> ( / ) \_\_\_\_\_  
24.950 MHz - TWO-TONE TRANSMIT IMD 3<sup>rd</sup>/5<sup>th</sup> ( / ) \_\_\_\_\_  
28.350 MHz - TWO-TONE TRANSMIT IMD 3<sup>rd</sup>/5<sup>th</sup> ( / ) \_\_\_\_\_  
50.200 MHz - TWO-TONE TRANSMIT IMD 3<sup>rd</sup>/5<sup>th</sup> ( / ) \_\_\_\_\_  
144.200 MHz - TWO-TONE TRANSMIT IMD 3<sup>rd</sup>/5<sup>th</sup> ( / ) \_\_\_\_\_  
432.200 MHz - TWO-TONE TRANSMIT IMD 3<sup>rd</sup>/5<sup>th</sup> ( / ) \_\_\_\_\_

Half-Power 14.250 MHz - TWO-TONE TRANSMIT IMD 3<sup>rd</sup>/5<sup>th</sup> ( / ) \_\_\_\_\_

**4.6 SSB CARRIER AND UNWANTED SIDEBAND SUPPRESSION TEST**

- 4.6.3.7 20M Level Of Suppressed Carrier/USB Mode: \_\_\_\_\_ dB Below PEP  
20M Level Of Unwanted Sideband/USB Mode: \_\_\_\_\_ dB Below PEP
- 4.6.3.8 20M Level Of Suppressed Carrier/LSB Mode: \_\_\_\_\_ dB Below PEP  
20M Level Of Unwanted Sideband/LSB Mode: \_\_\_\_\_ dB Below PEP
- 4.6.3.9 6M Level Of Suppressed Carrier/USB Mode: \_\_\_\_\_ dB Below PEP  
6M Level Of Unwanted Sideband/USB Mode: \_\_\_\_\_ dB Below PEP  
  
6M Level Of Suppressed Carrier/LSB Mode: \_\_\_\_\_ dB Below PEP  
6M Level Of Unwanted Sideband/LSB Mode: \_\_\_\_\_ dB Below PEP  
  
2M Level Of Suppressed Carrier/USB Mode: \_\_\_\_\_ dB Below PEP  
2M Level Of Unwanted Sideband/USB Mode: \_\_\_\_\_ dB Below PEP  
  
2M Level Of Suppressed Carrier/LSB Mode: \_\_\_\_\_ dB Below PEP  
2M Level Of Unwanted Sideband/LSB Mode: \_\_\_\_\_ dB Below PEP  
  
440 Level Of Suppressed Carrier/USB Mode: \_\_\_\_\_ dB Below PEP  
440 Level Of Unwanted Sideband/USB Mode: \_\_\_\_\_ dB Below PEP  
  
440 Level Of Suppressed Carrier/LSB Mode: \_\_\_\_\_ dB Below PEP  
440 Level Of Unwanted Sideband/LSB Mode: \_\_\_\_\_ dB Below PEP

**4.7 CW KEYING WAVEFORM TEST**

4.7.3.6 CW KEYING / QSK OFF ( )  
CW KEYING / QSK ON ( )  
CW KEYING - QSK & HALF POWER - SPIKE? ( )

4.7.3.7 Keying sidebands plots saved ( )

**4.8 PTT TO SSB/FM RF OUTPUT TEST**

4.8.3.5  
20M SSB 50% Delay ON Time: \_\_\_\_\_ms

4.8.3.6  
10M FM 50% Delay ON Time: \_\_\_\_\_ms

4.8.3.7  
6M FM 50% Delay ON Time: \_\_\_\_\_ms  
2M FM 50% Delay ON Time: \_\_\_\_\_ms  
440 FM 50% Delay ON Time: \_\_\_\_\_ms

**4.9 TRANSMIT/ RECEIVE TURNAROUND TIME TEST**

4.9.3.5 S9 Signal \* /AGC Slow/PTT Key-Up To 50% Audio Output  
Time: \_\_\_\_\_ms

4.9.3.6 S9 Signal \* /AGC Fast/PTT Key-Up To 50% Audio Output  
Time: \_\_\_\_\_ms

S9 -20 dB /AGC Slow/PTT Key-Up To 50% Audio Output  
Time: \_\_\_\_\_ms

No significant variation due to change in AGC or a 20 dB  
decrease in input signal ( ).

S9 Signal \* /AGC Fast/CW Mode/Key-Up to 50% Audio Output  
Time: \_\_\_\_\_ms

MDS + 10dB Signal/AGC Fast/CW Mode/Key-Up to 50% Audio Output  
Time: \_\_\_\_\_ms

4.9.3.7 DUT Suitable For AMTOR: \_\_\_\_\_YES \_\_\_\_\_NO

\*NOTE: If an S meter is not available, use standard 50  $\mu$ V input signal.

#### 4.10 KEYER SPEED AND SIDETONE

4.10.3.3 DOT to DASH ratio near 1:3 ( ).

4.10.3.4 Default keyer speed dit to dit time: \_\_\_\_\_ ms  
Code Speed (WPM): \_\_\_\_\_

4.10.3.5 Minimum keyer speed dit to dit time: \_\_\_\_\_ ms  
Code Speed (WPM): \_\_\_\_\_

4.10.3.6 Maximum keyer speed dit to dit time: \_\_\_\_\_ ms  
Code Speed (WPM): \_\_\_\_\_

4.10.3.7 Default sidetone: \_\_\_\_\_ Hz  
Minimum sidetone: \_\_\_\_\_ Hz  
Maximum sidetone: \_\_\_\_\_ Hz

#### 4.11 COMPOSITE NOISE TEST

4.11.3.13 Plot taken - Composite Noise at 14.025 MHz ( )  
Noise level at 2 kHz offset from carrier: \_\_\_\_\_ dBc/Hz  
Noise level at 22 kHz offset from carrier: \_\_\_\_\_ dBc/Hz

4.11.3.14 Plot taken - Composite Noise at 50.020 MHz ( )  
Noise level at 2 kHz offset from carrier: \_\_\_\_\_ dBc/Hz  
Noise level at 22 kHz offset from carrier: \_\_\_\_\_ dBc/Hz

Plot taken - Composite Noise at 144.020 MHz ( )  
Noise level at 2 kHz offset from carrier: \_\_\_\_\_ dBc/Hz  
Noise level at 22 kHz offset from carrier: \_\_\_\_\_ dBc/Hz

Plot taken - Composite Noise at 432.020 MHz ( )  
Noise level at 2 kHz offset from carrier: \_\_\_\_\_ dBc/Hz  
Noise level at 22 kHz offset from carrier: \_\_\_\_\_ dBc/Hz

5.0

RECEIVER TESTS

5.1 CW MINIMUM DISCERNIBLE SIGNAL (MDS) TEST

Standard (STD) Conditions: 10 dB Step Attn: 10 dB  
1 dB Step Attn: 0 dB

IF FILTERS: \_\_\_\_\_ Hz

5.1.3.8/

5.1.3.9 Can AGC be set to OFF?: \_\_\_\_\_

1.020 MHz Preamp Off, MDS: \_\_\_\_\_ dBm  
Preamp One, MDS: \_\_\_\_\_ dBm  
Preamp Two, MDS: \_\_\_\_\_ dBm

5.1.3.10

3.520 MHz Preamp Off, MDS: \_\_\_\_\_ dBm S5 Reference: \_\_\_\_\_ dBm  
Preamp One, MDS: \_\_\_\_\_ dBm S5 Reference: \_\_\_\_\_ dBm  
Preamp Two, MDS: \_\_\_\_\_ dBm S5 Reference: \_\_\_\_\_ dBm

5.1.3.11

14.020 MHz Preamp Off, MDS: \_\_\_\_\_ dBm S5 Reference: \_\_\_\_\_ dBm  
Preamp One, MDS: \_\_\_\_\_ dBm S5 Reference: \_\_\_\_\_ dBm  
Preamp Two, MDS: \_\_\_\_\_ dBm S5 Reference: \_\_\_\_\_ dBm

5.1.3.12

50.020 MHz Preamp Off, MDS: \_\_\_\_\_ dBm S5 Reference: \_\_\_\_\_ dBm  
Preamp One, MDS: \_\_\_\_\_ dBm S5 Reference: \_\_\_\_\_ dBm  
Preamp Two, MDS: \_\_\_\_\_ dBm S5 Reference: \_\_\_\_\_ dBm

144.020 MHz Preamp Off, MDS: \_\_\_\_\_ dBm S5 Reference: \_\_\_\_\_ dBm  
Preamp One, MDS: \_\_\_\_\_ dBm S5 Reference: \_\_\_\_\_ dBm  
Preamp Two, MDS: \_\_\_\_\_ dBm S5 Reference: \_\_\_\_\_ dBm

430.020 MHz Preamp Off, MDS: \_\_\_\_\_ dBm S5 Reference: \_\_\_\_\_ dBm  
Preamp One, MDS: \_\_\_\_\_ dBm S5 Reference: \_\_\_\_\_ dBm  
Preamp Two, MDS: \_\_\_\_\_ dBm S5 Reference: \_\_\_\_\_ dBm

5.2 AM RECEIVE SENSITIVITY TEST

Standard (STD) Conditions: 10 dB Step Attn: 10 dB  
1 dB Step Attn: 0 dB

IF FILTER \_\_\_\_\_ kHz

5.2.3.7/5.2.3.8

1.020 MHz Preamp off, 10 dB (S+N)/N: \_\_\_\_\_ μV  
Preamp one, 10 dB (S+N)/N: \_\_\_\_\_ μV  
Preamp two, 10 dB (S+N)/N: \_\_\_\_\_ μV

5.2.3.9

3.800 MHz Preamp off, 10 dB (S+N)/N: \_\_\_\_\_ μV  
Preamp one, 10 dB (S+N)/N: \_\_\_\_\_ μV  
Preamp two, 10 dB (S+N)/N: \_\_\_\_\_ μV

**5.2.3.10**

53.000 MHz Preamp off, 10 dB (S+N)/N: \_\_\_\_\_  $\mu$ V  
Preamp one, 10 dB (S+N)/N: \_\_\_\_\_  $\mu$ V  
Preamp two, 10 dB (S+N)/N: \_\_\_\_\_  $\mu$ V

120.000 MHz Preamp off, 10 dB (S+N)/N: \_\_\_\_\_  $\mu$ V  
(AIR) Preamp one, 10 dB (S+N)/N: \_\_\_\_\_  $\mu$ V  
Preamp two, 10 dB (S+N)/N: \_\_\_\_\_  $\mu$ V

146.000 MHz Preamp off, 10 dB (S+N)/N: \_\_\_\_\_  $\mu$ V  
Preamp one, 10 dB (S+N)/N: \_\_\_\_\_  $\mu$ V  
Preamp two, 10 dB (S+N)/N: \_\_\_\_\_  $\mu$ V

440.000 MHz Preamp off, 10 dB (S+N)/N: \_\_\_\_\_  $\mu$ V  
Preamp one, 10 dB (S+N)/N: \_\_\_\_\_  $\mu$ V  
Preamp two, 10 dB (S+N)/N: \_\_\_\_\_  $\mu$ V

**5.3 FM 12 dB SINAD TEST**

Standard (STD) Conditions: 10 dB Step Attn: 10 dB

1 dB Step Attn: 0 dB

IF Filters: \_\_\_\_\_ kHz (Normal/Narrow)

**5.3.3.5/5.3.3.6**

29.000 MHz Preamp off, 12 dB SINAD: \_\_\_\_\_  $\mu$ V \_\_\_\_\_ dBm  
(Normal/ Preamp one, 12 dB SINAD: \_\_\_\_\_  $\mu$ V \_\_\_\_\_ dBm  
Narrow) Preamp two, 12 dB SINAD: \_\_\_\_\_  $\mu$ V \_\_\_\_\_ dBm

**5.3.3.13**

52.000 MHz Preamp off, 12 dB SINAD: \_\_\_\_\_  $\mu$ V \_\_\_\_\_ dBm  
Preamp one, 12 dB SINAD: \_\_\_\_\_  $\mu$ V \_\_\_\_\_ dBm  
Preamp two, 12 dB SINAD: \_\_\_\_\_  $\mu$ V \_\_\_\_\_ dBm

100.000 MHz Preamp off, 12 dB SINAD: \_\_\_\_\_  $\mu$ V \_\_\_\_\_ dBm  
(Wide) Preamp one, 12 dB SINAD: \_\_\_\_\_  $\mu$ V \_\_\_\_\_ dBm  
Preamp one, 12 dB SINAD: \_\_\_\_\_  $\mu$ V \_\_\_\_\_ dBm

146.000 MHz Preamp off, 12 dB SINAD: \_\_\_\_\_  $\mu$ V \_\_\_\_\_ dBm  
Preamp one, 12 dB SINAD: \_\_\_\_\_  $\mu$ V \_\_\_\_\_ dBm  
Preamp two, 12 dB SINAD: \_\_\_\_\_  $\mu$ V \_\_\_\_\_ dBm

162.000 MHz Preamp off, 12 dB SINAD: \_\_\_\_\_  $\mu$ V \_\_\_\_\_ dBm  
Preamp one, 12 dB SINAD: \_\_\_\_\_  $\mu$ V \_\_\_\_\_ dBm  
Preamp two, 12 dB SINAD: \_\_\_\_\_  $\mu$ V \_\_\_\_\_ dBm

223.500 MHz Preamp off, 12 dB SINAD: \_\_\_\_\_  $\mu$ V \_\_\_\_\_ dBm  
 Preamp one, 12 dB SINAD: \_\_\_\_\_  $\mu$ V \_\_\_\_\_ dBm  
 Preamp two, 12 dB SINAD: \_\_\_\_\_  $\mu$ V \_\_\_\_\_ dBm

440.000 MHz Preamp off, 12 dB SINAD: \_\_\_\_\_  $\mu$ V \_\_\_\_\_ dBm  
 Preamp one, 12 dB SINAD: \_\_\_\_\_  $\mu$ V \_\_\_\_\_ dBm  
 Preamp two, 12 dB SINAD: \_\_\_\_\_  $\mu$ V \_\_\_\_\_ dBm

**5.4 RECEIVE FREQUENCY RANGE TEST**

	Band	Low Frequency Limit	High Frequency Limit
<b>5.4.3.4/</b>	160	_____ MHz	_____ MHz
<b>5.4.3.5</b>			
<b>5.4.3.6</b>	80	_____ MHz	_____ MHz
	60	_____ MHz	_____ MHz
	40	_____ MHz	_____ MHz
	30	_____ MHz	_____ MHz
	20	_____ MHz	_____ MHz
	17	_____ MHz	_____ MHz
	15	_____ MHz	_____ MHz
	12	_____ MHz	_____ MHz
	10	_____ MHz	_____ MHz
	6	_____ MHz	_____ MHz
	2	_____ MHz	_____ MHz
	440	_____ MHz	_____ MHz
	Other	_____ MHz	_____ MHz
	Other	_____ MHz	_____ MHz
	Other	_____ MHz	_____ MHz
	Other	_____ MHz	_____ MHz
	Other	_____ MHz	_____ MHz
General Coverage		_____ MHz	_____ MHz

All frequencies as measured on transmitter dial read-out.

**5.5 FIRST IF AND IMAGE REJECTION TEST**

Specified First Intermediate Frequency \_\_\_\_\_ MHz

IF or Calculated Image Frequency	MDS Level in dBm	IF or Image Suppression in dB

**5.7 BLOCKING GAIN COMPRESSION TEST**

Standard (STD) Conditions: 10 dB Step Attn: 10 dB  
 1 dB Step Attn: 0 dB

IF FILTERS \_\_\_\_\_ Hz

**5.7.3.5** Preamp off/ 1 dB Compression Point @ 3.520 MHz: \_\_\_\_\_ dBm  
 Preamp one/ 1 dB Compression Point @ 3.520 MHz: \_\_\_\_\_ dBm  
 Preamp two/ 1 dB Compression Point @ 3.520 MHz: \_\_\_\_\_ dBm

**5.7.3.7**

3.520 MHz Block level, Preamp off, lower (3.500 MHz): \_\_\_\_\_ dBm  
 Block level, Preamp off, lower (3.515 MHz): \_\_\_\_\_ dBm  
 Block level, Preamp off, lower (3.518 MHz): \_\_\_\_\_ dBm  
 Block level, Preamp off, upper (3.522 MHz): \_\_\_\_\_ dBm  
 Block level, Preamp off, upper (3.525 MHz): \_\_\_\_\_ dBm  
 Block level, Preamp off, upper (3.540 MHz): \_\_\_\_\_ dBm  
 Block level, Preamp one, lower (3.500 MHz): \_\_\_\_\_ dBm  
 Block level, Preamp one, upper (3.540 MHz): \_\_\_\_\_ dBm  
 Block level, Preamp two, lower (3.500 MHz): \_\_\_\_\_ dBm  
 Block level, Preamp two, upper (3.540 MHz): \_\_\_\_\_ dBm

**5.7.3.9** Preamp off/ 1 dB Compression Point @ 14.020 MHz: \_\_\_\_\_ dBm  
Preamp one/ 1 dB Compression Point @ 14.020 MHz: \_\_\_\_\_ dBm  
Preamp two/ 1 dB Compression Point @ 14.020 MHz: \_\_\_\_\_ dBm

14.020 MHz Block level, Preamp off, lower (14.000 MHz): \_\_\_\_\_ dBm  
Block level, Preamp off, lower (14.015 MHz): \_\_\_\_\_ dBm  
Block level, Preamp off, lower (14.018 MHz): \_\_\_\_\_ dBm  
Block level, Preamp off, upper (14.022 MHz): \_\_\_\_\_ dBm  
Block level, Preamp off, upper (14.025 MHz): \_\_\_\_\_ dBm  
Block level, Preamp off, upper (14.040 MHz): \_\_\_\_\_ dBm  
Block level, Preamp one, lower (14.000 MHz): \_\_\_\_\_ dBm  
Block level, Preamp one, upper (14.040 MHz): \_\_\_\_\_ dBm  
Block level, Preamp two, lower (14.000 MHz): \_\_\_\_\_ dBm  
Block level, Preamp two, upper (14.040 MHz): \_\_\_\_\_ dBm

Preamp off/ 1 dB Compression Point @ 50.020 MHz: \_\_\_\_\_ dBm  
Preamp one/ 1 dB Compression Point @ 50.020 MHz: \_\_\_\_\_ dBm  
Preamp two/ 1 dB Compression Point @ 50.020 MHz: \_\_\_\_\_ dBm

50.020 MHz Block level, Preamp off, lower (50.000 MHz): \_\_\_\_\_ dBm  
Block level, Preamp off, lower (50.015 MHz): \_\_\_\_\_ dBm  
Block level, Preamp off, lower (50.018 MHz): \_\_\_\_\_ dBm  
Block level, Preamp off, upper (50.022 MHz): \_\_\_\_\_ dBm  
Block level, Preamp off, upper (50.025 MHz): \_\_\_\_\_ dBm  
Block level, Preamp off, upper (50.040 MHz): \_\_\_\_\_ dBm  
Block level, Preamp one, lower (50.000 MHz): \_\_\_\_\_ dBm  
Block level, Preamp one, upper (50.040 MHz): \_\_\_\_\_ dBm  
Block level, Preamp two, lower (50.000 MHz): \_\_\_\_\_ dBm  
Block level, Preamp two, upper (50.040 MHz): \_\_\_\_\_ dBm

Preamp off/ 1 dB Compression Point @ 144.020 MHz: \_\_\_\_\_ dBm  
Preamp one/ 1 dB Compression Point @ 144.020 MHz: \_\_\_\_\_ dBm  
Preamp two/ 1 dB Compression Point @ 144.020 MHz: \_\_\_\_\_ dBm

144.020 MHz Block level, Preamp off, lower (144.000 MHz): \_\_\_\_\_ dBm  
Block level, Preamp off, lower (144.015 MHz): \_\_\_\_\_ dBm  
Block level, Preamp off, lower (144.018 MHz): \_\_\_\_\_ dBm  
Block level, Preamp off, upper (144.022 MHz): \_\_\_\_\_ dBm  
Block level, Preamp off, upper (144.025 MHz): \_\_\_\_\_ dBm  
Block level, Preamp off, upper (144.040 MHz): \_\_\_\_\_ dBm  
Block level, Preamp one, lower (144.000 MHz): \_\_\_\_\_ dBm  
Block level, Preamp one, upper (144.040 MHz): \_\_\_\_\_ dBm  
Block level, Preamp two, lower (144.000 MHz): \_\_\_\_\_ dBm  
Block level, Preamp two, upper (144.040 MHz): \_\_\_\_\_ dBm

Preamp off/ 1 dB Compression Point @ 430.020 MHz: \_\_\_\_\_ dBm  
Preamp one/ 1 dB Compression Point @ 430.020 MHz: \_\_\_\_\_ dBm  
Preamp two/ 1 dB Compression Point @ 430.020 MHz: \_\_\_\_\_ dBm

430.020 MHz Block level, Preamp off, lower (430.000 MHz): \_\_\_\_\_ dBm  
 Block level, Preamp off, lower (430.015 MHz): \_\_\_\_\_ dBm  
 Block level, Preamp off, lower (430.018 MHz): \_\_\_\_\_ dBm  
 Block level, Preamp off, upper (430.022 MHz): \_\_\_\_\_ dBm  
 Block level, Preamp off, upper (430.025 MHz): \_\_\_\_\_ dBm  
 Block level, Preamp off, upper (430.040 MHz): \_\_\_\_\_ dBm  
 Block level, Preamp one, lower (430.000 MHz): \_\_\_\_\_ dBm  
 Block level, Preamp one, upper (430.040 MHz): \_\_\_\_\_ dBm  
 Block level, Preamp two, lower (430.000 MHz): \_\_\_\_\_ dBm  
 Block level, Preamp two, upper (430.040 MHz): \_\_\_\_\_ dBm

**5.7A RECIPROCAL MIXING TEST**

+15 dBm Crystal Oscillator at 14.025 MHz

14.005 MHz, Preamp Off, Input level: \_\_\_\_\_ dBm  
 14.020 MHz, Preamp Off, Input level: \_\_\_\_\_ dBm  
 14.023 MHz, Preamp Off, Input level: \_\_\_\_\_ dBm  
 14.027 MHz, Preamp Off, Input level: \_\_\_\_\_ dBm  
 14.030 MHz, Preamp Off, Input level: \_\_\_\_\_ dBm  
 14.040 MHz, Preamp Off, Input level: \_\_\_\_\_ dBm  
 14.005 MHz, Preamp One, Input level: \_\_\_\_\_ dBm  
 14.040 MHz, Preamp One, Input level: \_\_\_\_\_ dBm  
 14.005 MHz, Preamp Two, Input level: \_\_\_\_\_ dBm  
 14.040 MHz, Preamp Two, Input level: \_\_\_\_\_ dBm

**5.8 TWO-TONE 3rd ORDER DYNAMIC RANGE TEST**

**5.8.3.6/5.8.3.7/5.8.3.8**

3.480/3.500 MHz Preamp Off, IMD level: \_\_\_\_\_ dBm S5: \_\_\_\_\_ dBm  
 3.510/3.515 MHz Preamp Off, IMD level: \_\_\_\_\_ dBm S5: \_\_\_\_\_ dBm  
 3.516/3.518 MHz Preamp Off, IMD level: \_\_\_\_\_ dBm S5: \_\_\_\_\_ dBm  
 3.522/3.524 MHz Preamp Off, IMD level: \_\_\_\_\_ dBm S5: \_\_\_\_\_ dBm  
 3.525/3.530 MHz Preamp Off, IMD level: \_\_\_\_\_ dBm S5: \_\_\_\_\_ dBm  
 3.540/3.560 MHz Preamp Off, IMD level: \_\_\_\_\_ dBm S5: \_\_\_\_\_ dBm

3.480/3.500 MHz Preamp One, IMD level: \_\_\_\_\_ dBm S5: \_\_\_\_\_ dBm  
 3.540/3.560 MHz Preamp One, IMD level: \_\_\_\_\_ dBm S5: \_\_\_\_\_ dBm

3.480/3.500 MHz Preamp Two, IMD level: \_\_\_\_\_ dBm S5: \_\_\_\_\_ dBm  
 3.540/3.560 MHz Preamp Two, IMD level: \_\_\_\_\_ dBm S5: \_\_\_\_\_ dBm

**5.8.3.11**

13.980/14.000 MHz Preamp Off, IMD level: \_\_\_\_\_ dBm S5: \_\_\_\_\_ dBm  
 14.010/14.015 MHz Preamp Off, IMD level: \_\_\_\_\_ dBm S5: \_\_\_\_\_ dBm  
 14.016/14.018 MHz Preamp Off, IMD level: \_\_\_\_\_ dBm S5: \_\_\_\_\_ dBm  
 14.022/14.024 MHz Preamp Off, IMD level: \_\_\_\_\_ dBm S5: \_\_\_\_\_ dBm  
 14.025/14.030 MHz Preamp Off, IMD level: \_\_\_\_\_ dBm S5: \_\_\_\_\_ dBm  
 14.040/14.060 MHz Preamp Off, IMD level: \_\_\_\_\_ dBm S5: \_\_\_\_\_ dBm

13.980/14.000 MHz Preamp One, IMD level: \_\_\_\_\_ dBm S5: \_\_\_\_\_ dBm  
 14.040/14.060 MHz Preamp One, IMD level: \_\_\_\_\_ dBm S5: \_\_\_\_\_ dBm

13.980/14.000	MHz	Preamp Two,	IMD level:	_____	dBm	S5:	_____	dBm
14.040/14.060	MHz	Preamp Two,	IMD level:	_____	dBm	S5:	_____	dBm
49.980/50.000	MHz	Preamp Off,	IMD level:	_____	dBm	S5:	_____	dBm
50.010/50.015	MHz	Preamp Off,	IMD level:	_____	dBm	S5:	_____	dBm
50.016/50.018	MHz	Preamp Off,	IMD level:	_____	dBm	S5:	_____	dBm
50.022/50.024	MHz	Preamp Off,	IMD level:	_____	dBm	S5:	_____	dBm
50.025/50.030	MHz	Preamp Off,	IMD level:	_____	dBm	S5:	_____	dBm
50.040/50.060	MHz	Preamp Off,	IMD level:	_____	dBm	S5:	_____	dBm
49.980/50.000	MHz	Preamp One,	IMD level:	_____	dBm	S5:	_____	dBm
50.040/50.060	MHz	Preamp One,	IMD level:	_____	dBm	S5:	_____	dBm
49.980/50.000	MHz	Preamp Two,	IMD level:	_____	dBm	S5:	_____	dBm
50.040/50.060	MHz	Preamp Two,	IMD level:	_____	dBm	S5:	_____	dBm



**5.9.3.6** 52.000 MHz/51.980 MHz  
Adjacent Channel Level for 6 dB SINAD: \_\_\_\_\_dBm

52.000 MHz/52.020 MHz  
Adjacent Channel Level for 6 dB SINAD: \_\_\_\_\_dBm

146.000 MHz/145.980 MHz  
Adjacent Channel Level for 6 dB SINAD: \_\_\_\_\_dBm

146.000 MHz/146.020 MHz  
Adjacent Channel Level for 6 dB SINAD: \_\_\_\_\_dBm

440.000 MHz/439.980 MHz  
Adjacent Channel Level for 6 dB SINAD: \_\_\_\_\_dBm

440.000 MHz/440.020 MHz  
Adjacent Channel Level for 6 dB SINAD: \_\_\_\_\_dBm

**5.9.3.8** Phase noise limit  
Phase Noise Limit Level at 28.980 MHz: \_\_\_\_\_dBm  
Phase Noise Limit Level at 29.020 MHz: \_\_\_\_\_dBm

**5.9.3.9**  
Phase Noise Limit Level at 51.980 MHz: \_\_\_\_\_dBm  
Phase Noise Limit Level at 52.020 MHz: \_\_\_\_\_dBm  
Phase Noise Limit Level at 145.980 MHz: \_\_\_\_\_dBm  
Phase Noise Limit Level at 146.020 MHz: \_\_\_\_\_dBm  
Phase Noise Limit Level at 439.980 MHz: \_\_\_\_\_dBm  
Phase Noise Limit Level at 440.020 MHz: \_\_\_\_\_dBm

**5.6.3.7** Adjacent Channel Rejection

#1 Gen	#2 Gen		#1 Gen	#2 Gen	
29.000	28.980	_____dB	29.000	29.020	_____dB
52.000	51.980	_____dB	52.000	52.020	_____dB
146.000	145.980	_____dB	146.000	146.020	_____dB
440.000	439.980	_____dB	440.000	440.020	_____dB

**5.10 FM TWO-TONE 3rd ORDER DYNAMIC RANGE TEST**

NOTE: 25% DISTORTION IS EQUAL TO 12 dB SINAD

Standard (STD) Conditions: RF Gen #1 and #2 Output

Level: -17 dBm

DUT Preamp: On

IF FILTERS \_\_\_\_\_ kHz

**5.10.3.5**

Generator frequencies: 28.960/28.980 MHz

Signal Level for 25% Distortion @ 29.000 MHz: \_\_\_\_\_ dBm

**5.10.3.6**

Generator frequencies: 29.020/29.040 MHz

Signal Level for 25% Distortion @ 29.000 MHz: \_\_\_\_\_ dBm

**5.10.3.8**

Generator frequencies: 51.960/51.980 MHz

Signal Level for 25% Distortion @ 52.000 MHz: \_\_\_\_\_ dBm

Generator frequencies: 52.020/52.040 MHz

Signal Level for 25% Distortion @ 52.000 MHz: \_\_\_\_\_ dBm

Generator frequencies: 62.000/72.000 MHz

Signal Level for 25% Distortion @ 52.000 MHz: \_\_\_\_\_ dBm

Generator frequencies: 145.960/145.980 MHz

Signal Level for 25% Distortion @ 146.000 MHz: \_\_\_\_\_ dBm

Generator frequencies: 146.020/146.040 MHz

Signal Level for 25% Distortion @ 146.000 MHz: \_\_\_\_\_ dBm

Generator frequencies: 156.000/166.000 MHz

Signal Level for 25% Distortion @ 146.000 MHz: \_\_\_\_\_ dBm

Generator frequencies: 439.960/439.980 MHz

Signal Level for 25% Distortion @ 440.000 MHz: \_\_\_\_\_ dBm

Generator frequencies: 440.020/440.040 MHz

Signal Level for 25% Distortion @ 440.000 MHz: \_\_\_\_\_ dBm

Generator frequencies: 450.000/460.000 MHz

Signal Level for 25% Distortion @ 440.000 MHz: \_\_\_\_\_ dBm

**5.11 AUDIO POWER OUTPUT TEST**

5.11.3.6 Specified Distortion: \_\_\_\_\_ % THD

Specified Load Impedance: \_\_\_\_\_ Ohms

5.11.3.7 Audio Voltage: \_\_\_\_\_ V

5.11.3.8 Audio Output Power: \_\_\_\_\_ W

5.11.3.9 Audio voltage at minimum volume (no signal): \_\_\_\_\_ mV  
(Hiss level)

**5.12 AUDIO AND IF FREQUENCY RESPONSE TEST**

5.12.3.6 IF Filters: \_\_\_\_\_ Hz (CW Narrow)

Low Frequency: \_\_\_\_\_ Hz

5.12.3.7 High Frequency: \_\_\_\_\_ Hz      Difference: \_\_\_\_\_ Hz

5.12.3.8 IF Filters: \_\_\_\_\_ Hz (USB Wide)

Low Frequency: \_\_\_\_\_ Hz

High Frequency: \_\_\_\_\_ Hz      Difference: \_\_\_\_\_ Hz

IF Filters: \_\_\_\_\_ kHz (LSB Wide)

Low Frequency: \_\_\_\_\_ Hz

High Frequency: \_\_\_\_\_ Hz      Difference: \_\_\_\_\_ Hz

5.12.3.10 IF Filters: \_\_\_\_\_ kHz (AM)

Low Frequency: \_\_\_\_\_ Hz

High Frequency: \_\_\_\_\_ Hz      Difference: \_\_\_\_\_ Hz

**5.13 SQUELCH SENSITIVITY TEST**

Standard (STD) Conditions: 10 dB Step Attn: 10 dB  
1 dB Step Attn: 0 dB  
Preamp On  
IF FILTERS \_\_\_\_\_ Hz

**5.13.3.5**

FM

29.000 MHz Squelch Threshold Point: \_\_\_\_\_  $\mu$ V

**5.13.3.6**

52.000 MHz Squelch Threshold Point: \_\_\_\_\_  $\mu$ V

146.000 MHz Squelch Threshold Point: \_\_\_\_\_  $\mu$ V

440.000 MHz Squelch Threshold Point: \_\_\_\_\_  $\mu$ V

**5.13.3.7**

SSB

14.200 MHz Squelch Threshold Point: \_\_\_\_\_  $\mu$ V

**5.14 S METER TEST**

Standard (STD) Conditions: 10 dB Step Attn: 10 dB  
1 dB Step Attn: 0 dB  
IF FILTERS \_\_\_\_\_ Hz

**5.14.3.4/5.14.3.5**

14.200 MHz Preamp Off, S9 Indication: \_\_\_\_\_ dBm \_\_\_\_\_  $\mu$ V  
No significant deviation from expected level  
at S9+20 dB( ).

**5.14.3.6**

14.200 MHz Preamp One, S9 Indication: \_\_\_\_\_ dBm \_\_\_\_\_  $\mu$ V  
No significant deviation from expected level  
at S9+20 dB( ).

14.200 MHz Preamp Two, S9 Indication: \_\_\_\_\_ dBm \_\_\_\_\_  $\mu$ V  
No significant deviation from expected level  
at S9+20 dB( ).

### 5.14.3.7

- 1.020 MHz Preamp Off, S9 Indication: \_\_\_\_\_ dBm \_\_\_\_\_  $\mu$ V  
No significant deviation from expected level  
at S9+20 dB( ).
- 1.020 MHz Preamp One, S9 Indication: \_\_\_\_\_ dBm \_\_\_\_\_  $\mu$ V  
No significant deviation from expected level  
at S9+20 dB( ).
- 1.020 MHz Preamp Two, S9 Indication: \_\_\_\_\_ dBm \_\_\_\_\_  $\mu$ V  
No significant deviation from expected level  
at S9+20 dB( ).
- 50.020 MHz Preamp Off, S9 Indication: \_\_\_\_\_ dBm \_\_\_\_\_  $\mu$ V  
No significant deviation from expected level  
at S9+20 dB( ).
- 50.020 MHz Preamp One, S9 Indication: \_\_\_\_\_ dBm \_\_\_\_\_  $\mu$ V  
No significant deviation from expected level  
at S9+20 dB( ).
- 50.020 MHz Preamp Two, S9 Indication: \_\_\_\_\_ dBm \_\_\_\_\_  $\mu$ V  
No significant deviation from expected level  
at S9+20 dB( ).
- 144.020 MHz Preamp Off, S9 Indication: \_\_\_\_\_ dBm \_\_\_\_\_  $\mu$ V  
No significant deviation from expected level  
at S9+20 dB( ).
- 144.020 MHz Preamp One, S9 Indication: \_\_\_\_\_ dBm \_\_\_\_\_  $\mu$ V  
No significant deviation from expected level  
at S9+20 dB( ).
- 144.020 MHz Preamp Two, S9 Indication: \_\_\_\_\_ dBm \_\_\_\_\_  $\mu$ V  
No significant deviation from expected level  
at S9+20 dB( ).
- 420.020 MHz Preamp Off, S9 Indication: \_\_\_\_\_ dBm \_\_\_\_\_  $\mu$ V  
No significant deviation from expected level  
at S9+20 dB( ).
- 420.020 MHz Preamp One, S9 Indication: \_\_\_\_\_ dBm \_\_\_\_\_  $\mu$ V  
No significant deviation from expected level  
at S9+20 dB( ).
- 420.020 MHz Preamp Two, S9 Indication: \_\_\_\_\_ dBm \_\_\_\_\_  $\mu$ V  
No significant deviation from expected level  
at S9+20 dB( ).

## 5.16 NOTCH FILTER TEST

5.16.3.6 Minimum Notch Depth: \_\_\_\_\_dB

5.16.3.11 Maximum Notch Depth: \_\_\_\_\_dB

5.16.3.17 Notch Attack Time: \_\_\_\_\_ms

Test options -

2 tones (S9 each), AGC on, manual notch

2 tones (S9 + S1), AGC on, manual notch

1 tone, AGC on, manual notch

1 tone, AGC off, manual notch

1 tone, AGC on, auto notch

1 tone, AGC off, auto notch

Note changes in tone level and noise level.

Also note changes in S-meter for AGC on tests.

## 6.2 DSP NOISE REDUCTION TEST

6.2.3.5 S9 Signal, best case noise reduction: \_\_\_\_\_dB

6.2.3.6 Overall best case noise reduction: \_\_\_\_\_dB

**6.0 NON-STANDARD & SPECIAL PURPOSE TESTS**

**6.1 LOW VOLTAGE AND TEMPERATURE CHAMBER TEST**

6.1.3.4 Room Temperature, 13.8V dc  
Power Output (Bird): \_\_\_\_\_ W  
Frequency: \_\_\_\_\_ MHz

6.1.3.5 Room Temperature, 13.8V dc  
Minimum Discernable Signal: \_\_\_\_\_ dBm

6.1.3.5 Room Temperature, Low Voltage (11.5V nominal)  
Power Output (Bird): \_\_\_\_\_ W  
Frequency: \_\_\_\_\_ MHz  
Minimum Discernable Signal: \_\_\_\_\_ dBm

6.1.3.6 Low Temperature (-10 deg. C nominal), 13.8V dc  
Power Output (Bird): \_\_\_\_\_ W  
Frequency: \_\_\_\_\_ MHz  
Minimum Discernable Signal: \_\_\_\_\_ dBm

6.1.3.7 High Temperature (+60 deg. C nominal), 13.8V dc  
Power Output (Bird): \_\_\_\_\_ W  
Frequency: \_\_\_\_\_ MHz  
Minimum Discernable Signal: \_\_\_\_\_ dBm

6.1.3.8 Room Temperature, 13.8V dc  
Power Output (Bird): \_\_\_\_\_ W  
Frequency: \_\_\_\_\_ MHz  
Minimum Discernable Signal: \_\_\_\_\_ dBm  
DUT Functions Normally ( ).

**6.3 RECEIVER BIT ERROR RATE TEST**

6.3.3.7 146 MHz, BER for 12-dB SINAD: \_\_\_\_\_  
146 MHz, BER for 16-dB SINAD: \_\_\_\_\_  
146 MHz, BER for -50 dBm: \_\_\_\_\_  
  
440 MHz, BER for 12-dB SINAD: \_\_\_\_\_  
440 MHz, BER for 16-dB SINAD: \_\_\_\_\_  
440 MHz, BER for -50 dBm: \_\_\_\_\_

**6.4 TRANSMITTER BIT ERROR RATE TEST**

6.4.3.9 146 MHz, BER for 12 dB SINAD: \_\_\_\_\_  
146 MHz, BER for SINAD + 30 dB: \_\_\_\_\_  
  
440 MHz, BER for 12 dB SINAD: \_\_\_\_\_  
440 MHz, BER for SINAD + 30 dB: \_\_\_\_\_

## 6.5 RECEIVER PHASE NOISE TEST

### 6.5.3.4 1 kHz offset, crystal oscillator level

#### 6.5.3.5

14.026 MHz, oscillator level:	_____	dBm
14.027 MHz, oscillator level:	_____	dBm
14.028 MHz, oscillator level:	_____	dBm
14.029 MHz, oscillator level:	_____	dBm
14.030 MHz, oscillator level:	_____	dBm
14.032 MHz, oscillator level:	_____	dBm
14.034 MHz, oscillator level:	_____	dBm
14.036 MHz, oscillator level:	_____	dBm
14.038 MHz, oscillator level:	_____	dBm
14.040 MHz, oscillator level:	_____	dBm
14.042 MHz, oscillator level:	_____	dBm
14.044 MHz, oscillator level:	_____	dBm
14.046 MHz, oscillator level:	_____	dBm
14.048 MHz, oscillator level:	_____	dBm
14.050 MHz, oscillator level:	_____	dBm
14.055 MHz, oscillator level:	_____	dBm
14.060 MHz, oscillator level:	_____	dBm
14.065 MHz, oscillator level:	_____	dBm
14.070 MHz, oscillator level:	_____	dBm
14.075 MHz, oscillator level:	_____	dBm
14.080 MHz, oscillator level:	_____	dBm
14.085 MHz, oscillator level:	_____	dBm
14.090 MHz, oscillator level:	_____	dBm
14.105 MHz, oscillator level:	_____	dBm
14.115 MHz, oscillator level:	_____	dBm
14.125 MHz, oscillator level:	_____	dBm
14.135 MHz, oscillator level:	_____	dBm
14.145 MHz, oscillator level:	_____	dBm
14.155 MHz, oscillator level:	_____	dBm
14.165 MHz, oscillator level:	_____	dBm
14.175 MHz, oscillator level:	_____	dBm
14.200 MHz, oscillator level:	_____	dBm
14.225 MHz, oscillator level:	_____	dBm
14.250 MHz, oscillator level:	_____	dBm
14.275 MHz, oscillator level:	_____	dBm
14.325 MHz, oscillator level:	_____	dBm
14.375 MHz, oscillator level:	_____	dBm
14.425 MHz, oscillator level:	_____	dBm
14.525 MHz, oscillator level:	_____	dBm

**5.1.3.13 Expanded Tests**

1.820 MHz Preamp Off, MDS: \_\_\_\_\_ dBm  
Preamp One, MDS: \_\_\_\_\_ dBm  
Preamp Two, MDS: \_\_\_\_\_ dBm

7.020 MHz Preamp Off, MDS: \_\_\_\_\_ dBm  
Preamp One, MDS: \_\_\_\_\_ dBm  
Preamp Two, MDS: \_\_\_\_\_ dBm

10.120 MHz Preamp Off, MDS: \_\_\_\_\_ dBm  
Preamp One, MDS: \_\_\_\_\_ dBm  
Preamp Two, MDS: \_\_\_\_\_ dBm

18.088 MHz Preamp Off, MDS: \_\_\_\_\_ dBm  
Preamp One, MDS: \_\_\_\_\_ dBm  
Preamp Two, MDS: \_\_\_\_\_ dBm

21.020 MHz Preamp Off, MDS: \_\_\_\_\_ dBm  
Preamp One, MDS: \_\_\_\_\_ dBm  
Preamp Two, MDS: \_\_\_\_\_ dBm

24.910 MHz Preamp Off, MDS: \_\_\_\_\_ dBm  
Preamp One, MDS: \_\_\_\_\_ dBm  
Preamp Two, MDS: \_\_\_\_\_ dBm

28.020 MHz Preamp Off, MDS: \_\_\_\_\_ dBm  
Preamp One, MDS: \_\_\_\_\_ dBm  
Preamp Two, MDS: \_\_\_\_\_ dBm

**5.6 ANTENNA PORT ISOLATION TEST**

Number of antenna ports: \_\_\_\_\_

Level of signal on opposite port for MDS on desired port

Desired Port: _____	Opposite Port: _____	Signal level: _____	dBm
Desired Port: _____	Opposite Port: _____	Signal level: _____	dBm
Desired Port: _____	Opposite Port: _____	Signal level: _____	dBm
Desired Port: _____	Opposite Port: _____	Signal level: _____	dBm
Desired Port: _____	Opposite Port: _____	Signal level: _____	dBm

### 5.7.3.11 Swept Blocking Dynamic Range

Lower Frequencies	Block Level (dBm)	Upper Frequencies	Block Level (dBm)
13.820 MHz		14.220 MHz	
13.840 MHz		14.200 MHz	
13.860 MHz		14.180 MHz	
13.880 MHz		14.160 MHz	
13.900 MHz		14.140 MHz	
13.920 MHz		14.120 MHz	
13.940 MHz		14.100 MHz	
13.960 MHz		14.080 MHz	
13.965 MHz		14.075 MHz	
13.970 MHz		14.070 MHz	
13.975 MHz		14.065 MHz	
13.980 MHz		14.060 MHz	
13.985 MHz		14.055 MHz	
13.990 MHz		14.050 MHz	
13.992 MHz		14.048 MHz	
13.994 MHz		14.046 MHz	
13.996 MHz		14.044 MHz	
13.998 MHz		14.042 MHz	
14.000 MHz		14.040 MHz	
14.002 MHz		14.038 MHz	
14.004 MHz		14.036 MHz	
14.006 MHz		14.034 MHz	
14.008 MHz		14.032 MHz	
14.010 MHz		14.030 MHz	
14.012 MHz		14.028 MHz	
14.014 MHz		14.026 MHz	
14.015 MHz		14.025 MHz	
14.016 MHz		14.024 MHz	
14.017 MHz		14.023 MHz	
14.018 MHz		14.022 MHz	
14.019 MHz		14.021 MHz	

### 5.8.3.18 Swept IMD Dynamic Range (Cont.)

First Generator Frequency	Second Generator Frequency	Level for MDS IMD Response	First Generator Frequency	Second Generator Frequency	Level for MDS IMD Response
13.620 MHz	13.820 MHz		14.022 MHz	14.021 MHz	
13.660 MHz	13.840 MHz		14.024 MHz	14.022 MHz	
13.700 MHz	13.860 MHz		14.026 MHz	14.023 MHz	
13.740 MHz	13.880 MHz		14.028 MHz	14.024 MHz	
13.780 MHz	13.900 MHz		14.030 MHz	14.025 MHz	
13.820 MHz	13.920 MHz		14.032 MHz	14.026 MHz	
13.860 MHz	13.940 MHz		14.036 MHz	14.028 MHz	
13.900 MHz	13.960 MHz		14.040 MHz	14.030 MHz	
13.910 MHz	13.965 MHz		14.044 MHz	14.032 MHz	
13.920 MHz	13.970 MHz		14.048 MHz	14.034 MHz	
13.930 MHz	13.975 MHz		14.052 MHz	14.036 MHz	
13.940 MHz	13.980 MHz		14.056 MHz	14.038 MHz	
13.950 MHz	13.985 MHz		14.060 MHz	14.040 MHz	
13.960 MHz	13.990 MHz		14.064 MHz	14.042 MHz	
13.964 MHz	13.992 MHz		14.068 MHz	14.044 MHz	
13.968 MHz	13.994 MHz		14.072 MHz	14.046 MHz	
13.972 MHz	13.996 MHz		14.076 MHz	14.048 MHz	
13.976 MHz	13.998 MHz		14.080 MHz	14.050 MHz	
13.980 MHz	14.000 MHz		14.090 MHz	14.055 MHz	
13.984 MHz	14.002 MHz		14.100 MHz	14.060 MHz	
13.988 MHz	14.004 MHz		14.110 MHz	14.065 MHz	
13.992 MHz	14.006 MHz		14.120 MHz	14.070 MHz	
13.996 MHz	14.008 MHz		14.130 MHz	14.075 MHz	
14.000 MHz	14.010 MHz		14.140 MHz	14.080 MHz	
14.004 MHz	14.012 MHz		14.180 MHz	14.100 MHz	
14.008 MHz	14.014 MHz		14.220 MHz	14.120 MHz	
14.010 MHz	14.015 MHz		14.260 MHz	14.140 MHz	
14.012 MHz	14.016 MHz		14.300 MHz	14.160 MHz	
14.014 MHz	14.017 MHz		14.340 MHz	14.180 MHz	
14.016 MHz	14.018 MHz		14.380 MHz	14.200 MHz	
14.018 MHz	14.019 MHz		14.420 MHz	14.220 MHz	

## 5.15 IN-BAND IMD TEST

- 5.15.3.6 14.200 MHz, AGC Fast, S9 Signals, plot taken ( ).
- 14.200 MHz, AGC Fast, S9 Signals, plot taken ( ).
- 14.200 MHz, AGC Fast, S9+40/60 Signals, plot taken ( ).
- 14.200 MHz, AGC Fast, S9+40/60 Signals, plot taken ( ).

## 6.7 HF LINEAR AMPLIFIER TEST

6.7.1 The purpose of the Linear Amplifier Test is to determine if the amplifier meets the manufacturer's power output specification, meets FCC Part 97 regarding Spurious Emissions and measure and record the level of Intermodulation Distortion.

It is very important for the test engineer to be familiar with the Lab test equipment and the Device Under Test (DUT). The manufacturer's manual should be completely read and understood before any testing is performed. At no time should any equipment be operated in a manner that is inconsistent with the manufacturer's recommended procedures or published limits. Failure to understand the DUT could result in test error, damage to the equipment and worse, damage to the test engineer.

6.7.2 List of Equipment:

Instrument	Manufacturer	Model	Quantity
Spectrum Analyzer	HP	8563E	1
In-Line RF Wattmeter	Bird	4381	1
In-Line RF Wattmeter	Bird	43	2
Power Attenuator	Bird	8329	1
RF Step Attenuator	HP	355C	1
RF Step Attenuator	HP	355D	1
Fixed RF Attenuator	Bird	8340-100	1
Fixed RF Attenuator	Bird	8340-200	1
Signal Generator	Any	Any	2
Driver Amplifier	ARRL	N/A	2
150W Power Amplifier	CCI	EB63	2
14 MHz Power Combiner	ARRL	NA	1
Inter-Connecting Cables	NA	As Required	As Required

### 6.7A LINEAR AMPLIFIER OPERATION TEST

6.7A.1 The purpose of the Linear Amplifier Operation Test is to determine the ability of the amplifier to produce its full rated output power in each applicable Amateur Band without exceeding any of the manufacturer's specified limits. The input drive power, the input reflected power, the output forward and reflected power and the spurious emissions are measured at each test point. Measurements are made at the edges of the bands and one or more mid-band points. The spectral display on each band is saved to disc. Additionally, the Linear Amplifier will be tested with an input signal of 27 MHz to ensure the amplifier does not function on the Citizen's Band.

6.7A.2 Test Hook-Up (See FIGURE 6.7A)

Diagram here:

6.7A.3 With all power switches in the OFF position and the signal generator outputs disabled, connect the following:

<u>CONNECTION</u>	<u>CONNECTORS</u>	<u>CABLE TYPE</u>
Signal Generator Out to Driver #1 In	Type N to BNC	RG-58
Driver #1 Out to Linear Amp #1 In	BNC to BNC	RG-58
Linear Amp #1 Out to	BNC to BNC	RG-58

Filter #1 In

Filter #1 Out to Bird 43 Wattmeter In	BNC to PL-259	RG-58
Bird 43 Wattmeter Out to DUT In	PL-259 to As Required	RG-58
DUT Out to Bird 4381 Wattmeter In	As required to type N	RG-8
Bird 4381 Wattmeter Out to Power Attenuator In	Type N to type N	RG-8
Power Attenuator Out to 20 dB Attenuator In	Type N to type N	RG-58
20 dB Attenuator Out to 10 dB Step Attenuator In	Type N to BNC	RG-58
10 dB Step Attenuator Out to 1 dB Step Attenuator In	BNC to BNC	RG-58
1 dB Step Attenuator Out to Spectrum Analyzer In	BNC to BNC	RG-58

6.7A.4 Set the following controls in the order shown

<u>INSTRUMENT</u>	<u>CONTROL</u>	<u>POSITION</u>
DUT	Operate/Standby	Standby
DUT	Power On/Off	On
DUT	TUNE	Pre-set for 160 m
DUT	Load	Pre-set for 160 m
DUT	CW/SSB	CW
Bird 4381	Power On/Off	ON
Bird 4381	Function	FWD CW
Bird 4381	Forward Element	As Required
Bird 43	Element	As Required
Bird 43	Element Direction	Forward
10 dB Step Attn	Attenuator	>20 dB
1 dB Step Attn	Attenuator	Any
Signal Generator	Modulation	Off
Signal Generator	Frequency	1.800 MHz
Signal Generator	Carrier Off/On	Off
Signal Generator	RF Level	< -40dBm
**Spectrum Analyzer	Reference Level	-10dBm
Spectrum Analyzer	Input Attenuation	20 dB
Spectrum Analyzer	Threshold	-80 dBm
Spectrum Analyzer	Resolution Bandwidth	10 kHz
Spectrum Analyzer	Video Bandwidth	30 kHz
Spectrum Analyzer	Range MHz	0 to 50 MHz
Spectrum Analyzer	Sweep Time	Auto

**\*\* NOTE:** The spectrum analyzer is automatically set to these values when using the LabWindows/CVI software.

6.7A.5 Allow the equipment to warm up for at least 10 minutes before proceeding to the next step.

6.7A.6 Check to make sure all power switches are on, including the filament switch if the DUT has one.

6.7A.7 If the DUT is of the vacuum tube type, the tuning of the amplifier must be performed in a manner consistent with all DUT and vacuum tube limits. Be sure not to exceed the maximum plate current, grid current and DUT power output limits while performing the following steps. If the amplifier is of the solid state type, be sure not to exceed the final PA maximum operating temperature and duty cycle limit.

NOTE: Some of the tuning steps may be omitted when the DUT is of the solid state type. Usually, there are no tuning adjustments, such as Plate and Load. Follow the procedure for adjusting the amplifier's drive level for the rated output.

6.7A.8 Switch the DUT to the Operate mode and enable the carrier on the generator. Increase the generator level until a moderate amount of RF is produced but the DUT (consult the operator's manual for the recommended drive level for tune-up). Tune the DUT per the manufacturer's instructions, for the maximum power output without exceeding the maximum rated power output.

Be sure to adjust the generator as necessary if the rated output is exceeded.

6.7A.9 Measure and record on the data sheet the following items:

<u>MEASUREMENT</u>	<u>INSTRUMENT</u>
Forward Power	Bird 43
Reflected Power	Bird 43
Plate Voltage	DUT Meter
Plate Current	DUT Meter
Grid Current	DUT Meter
Output Power	Bird 4381

6.7A.9.1 Adjust the step attenuators to provide approximately -10 dBm input to the spectrum analyzer (the fundamental should be just at the top of the frequency sweep display).

**NOTE:** *At no time should the input to the spectrum analyzer exceed 0 dBm. Damage to the instrument will occur at +10 dBm or greater !*

6.7A.9.2 If using the LabWindows/CVI software, click on the READ ANALYZER button to acquire data from the analyzer and display it on the screen. The level of the harmonics and/or spurs, in dB below the fundamental, can be read on the analyzer using the delta function. Note worst case harmonic and spur and record it on the data sheet. Disable the carrier on the signal generator.

6.7A.9.3 Set the generator frequency to the next value on the data sheet and retune the DUT as necessary. Repeat step 6.7A.9 for this test frequency. Again, repeat this step incrementing the generator's frequency each time, until the upper limit of the Amateur Band is reached.

6.7A.9.4 Repeat the above steps for each of the available Amateur Bands for each frequency on the data sheet. For 10 to 20 MHz, set the spectrum analyzer for a frequency range of 0 to 100 MHz. For 20 to 30 MHz, set the spectrum analyzer for a frequency range of 0 to 200 MHz.

## 6.7B LINEAR AMPLIFIER IMD TEST

6.7A.1 The purpose of the Linear Amplifier IMD Test is to measure and record the IMD products generated within the DUT when subjected to two simultaneous input signals. This test is performed by generating two RF signals (at 14.020 and 14.0212 MHz), amplifying them to an appropriate drive level, combining the amplified signals and feeding them to the DUT input. The DUT output IMD products are then displayed on the spectrum analyzer.

6.7B.2 Test Hook-Up (See Figure 6.7B)

Diagram here:

6.7B.3 With all power switches in the off position and both signal generator carriers disabled, connect the following:

<u>CONNECTION</u>	<u>CONNECTORS</u>	<u>CABLE TYPE</u>
Signal Generator #1 Out to Driver #1 In	Type N to BNC	RG-58
Signal Generator #2 Out to Driver #2 In	Type N to BNC	RG-58
Driver #1 Out to Linear Amp #1 In	BNC to BNC	RG-58
Driver #2 Out to Linear Amp #2 In	BNC to BNC	RG-58
Linear Amp #1 Out to Filter #1 In	BNC to BNC	RG-58
Linear Amp #2 Out to Filter #2 In	BNC to BNC	RG-58
Filter #1 Out to Bird 43 #1 In	BNC to PL-259	RG-58
Filter #2 Out to Bird 43 #2 In	BNC to PL-259	RG-58
Bird 43 #1 Out to Power Combiner #1 In	PL-259 to As Required	RG-58
Bird 43 #1 Out to Power Combiner #2 In	PL-259 to As Required	RG-58
Combiner 50 Ohm Out to 100 Watt Dummy Load	BNC to SO-239	RG-58
Combiner RF Out to DUT RF In	BNC to As Required	RG-58
DUT RF Out to Bird 4381 In	As Required to Type N	RG-8
Bird 4381 Out to Power Attenuator In	Type N to Type N	RG-8
Power Attenuator Out to 20 dB Attenuator In	Type N to Type N	RG-58
20 dB Attenuator Out to 10 dB Step Attn In	Type N to BNC	RG-58
10 dB Step Attn Out to 1 dB Step Attn In	BNC to BNC	RG-58
1 dB Step Attn Out to Spectrum Analyzer In	BNC to Type N	RG-58

6.7B.4 Set the following controls in the order shown

INSTRUMENT	CONTROL	POSITION
DUT	Operate/Standby	Standby
DUT	Power On/Off	On
DUT	TUNE	Pre-set for 20 m
DUT	LOAD	Pre-set for 20 m
DUT	CW/SSB	CW
Bird 4381	Power On/Off	On
Bird 4381	Function	FWD CW
Bird 4381	Forward Element	As Required
Bird 43	Element	As required
Bird 43	Element Direction	Forward
10 dB Step Attn	Attenuator	> 40 dB
1 dB Step Attn	Attenuator	Any
Generator #1	Modulation	Off
Generator #1	Frequency	14.020 MHz
Generator #1	Carrier On/Off	Off
Generator #1	RF Level	-40dBm
Generator #2	Modulation	Off
Generator #2	Frequency	14.0212 MHz
Generator #2	Carrier On/Off	Off
Generator #2	RF Level	-40 dBm
**Spectrum Analyzer	Input Attenuation	20 dB
Spectrum Analyzer	Reference Level	-40 dBm
Spectrum Analyzer	Threshold	-110 dBm
Spectrum Analyzer	Resolution Bandwidth	100 Hz
Spectrum Analyzer	Video bandwidth	10 kHz
Spectrum Analyzer	Center Frequency	14.0206 MHz
Spectrum Analyzer	Span	20 kHz
Spectrum Analyzer	Sweep Time	Auto

\*\* NOTE: The spectrum Analyzer is automatically configured to these values when using the LabWindows/CVI software.

6.7B.5 Allow all equipment to warm up for at least 10 minutes before proceeding to the next step.

6.7B.6 Enable the carrier on Signal Generator #1. Proceed with DUT tuning adjustments as described in the Operation Test. When the DUT tuning is complete, disable the carrier on Signal Generator #1 and reduce its level back to -40 dBm.

6.7B.7 Enable the carrier on both signal generators. Simultaneously, the RF level of both generators slowly until the DUT is operating at about 50% of its rated power output.

6.7B.8 Observe the spectrum analyzer display and adjust the signal generator levels for equal power of the two signals on the spectral display. (Be sure to monitor the DUT's Grid and Plate Current if DUT is a Tube type to keep them within the manufacturer's limits.)

6.7B.9 Adjust the impedance matching controls on the test fixture for minimum SWR (Note that the dummy load matching network shouldn't have to be readjusted after the initial adjustment unless a fixture change has been made).

6.7B.10 If the DUT is not yet at full rated power at this point, slowly increase the signal generator levels simultaneously to bring the power up to the rated full power output. Adjust the step attenuators to adjust the signal peaks to 6 dB below the reference level on the spectrum analyzer.

6.7B.11 Readjust the fixture impedance matching controls if needed and trigger the spectrum analyzer sweep to obtain a static trace. Disable the signal generator carriers to remove the drive to the DUT. *Is it getting hot in there or what ?*

6.7B.12 If using the LabWindows/CVI software, click on the READ ANALYZER button to acquire data from the analyzer and display it on the computer screen. The level of the IMD products, in dB below the PEP level can be directly read off the displayed data. Save the results to a file.

6.7B.13 Record the 3rd and 5th IMD product levels on the data sheet.

## LINEAR AMPLIFIER PRODUCT REVIEW DATA SHEET

Manufacturer: \_\_\_\_\_ Model: \_\_\_\_\_ Serial #: \_\_\_\_\_

Date: \_\_\_\_\_ Test Engineer: \_\_\_\_\_

Band (M)	Frequency (MHz)	DRIVE DUT			Bird Po (W)	SP/PUR (dBc)	NOTES
		PFWD (W)	PREF (W)	Po (W)			
160	1.801	_____	_____	_____	_____	_____	1.999
	1.900	_____	_____	_____	_____	_____	
80	3.501	_____	_____	_____	3.999	_____	3.750
		_____	_____	_____	_____	_____	_____
40	7.001	_____	_____	_____	_____	_____	7.299
20	14.001	_____	_____	_____	_____	_____	_____
	14.250	_____	_____	_____	_____	_____	_____
	14.449	_____	_____	_____	_____	_____	_____
17	18.069	_____	_____	_____	_____	_____	_____
	18.167	_____	_____	_____	_____	_____	_____
15	21.001	_____	_____	_____	_____	_____	_____
	21.250	_____	_____	_____	_____	_____	_____
	21.449	_____	_____	_____	_____	_____	_____
12	24.891	_____	_____	_____	_____	_____	_____
	24.898	_____	_____	_____	_____	_____	_____
10	28.001	_____	_____	_____	_____	_____	28.850
	29.000	_____	_____	_____	_____	_____	_____
	29.699	_____	_____	_____	_____	_____	_____
6	50.001	_____	_____	_____	_____	_____	51.000
	50.400	_____	_____	_____	_____	_____	
	52.000	_____	_____	_____	_____	_____	
	53.000	_____	_____	_____	_____	_____	
	53.999	_____	_____	_____	_____	_____	

Worst Case Spectral Purity: \_\_\_\_\_

Two-Tone IMD, 20 Meters: 3rd: \_\_\_\_\_ 5th: \_\_\_\_\_ 7th: \_\_\_\_\_ 9th: \_\_\_\_\_ dBc

Test Engineer's Notes:

---

---

## About the Linear Amplifier IMD Test Fixture

To test for intermodulation distortion (IMD) in power amplifiers, two closely spaced RF signals are necessary. Since a single transmitter would introduce its own IMD into the test setup; two transmitters are used instead, with their outputs combined in a power combiner. An inexpensive hybrid combiner may be constructed using RG-8 and RG-11 coax for a particular design frequency. Slight amounts of reactance at the load port and output port can cause degraded isolation between the input ports, so impedance matching networks are used to adjust these ports for a pure resistive load.

For convenience sake, the entire test setup is mounted in a 6-foot tall equipment rack, mounted on wheels for a limited degree of portability.

In place of two amateur transceivers or transmitters, signal generators and appropriate amplification may also be used. This allows better control of the power levels as well as improved frequency accuracy and stability. This is the approach taken in the ARRL Lab.

Figure 6.7B provides an overview of the test fixture and interconnections used in the test setup. The two signal generators used must be capable of an output up to about +10dBm. Drivers 1 & 2 are an ARRL design. The schematic of the drivers appears in figure 6.7BA. The linear amplifiers are Communications Concepts model EB63. The filters are 20 meter band pass units made by Ed Wetherhold, W3NQN and were described in the May and June 1998 issues of QST. A copy of this article appears in Appendix B. Similar filters may be substituted. The power combiner is a coaxial hybrid ring adapted from a design for 2 meters and 440 MHz that appeared in the 1998 Central States VHF Conference Proceedings. A copy of this paper also appears in Appendix B.

The RF Sampling Unit is also an ARRL design. The schematic for this circuit appears in Appendix B. The Directional Coupler is a Tandem Match Design. The circuit of the Tandem Match appeared in January, 1987 QST (also in Appendix B). The PI network used to tune out the stray reactance of the dummy load consists of a 0.432 micro Henry coil and two variable capacitors with a nominal value of 104 Pico farads. The T network used to match the input impedance of the amplifiers under test consists of a 1.07 micro Henry coil and two variable capacitors with a nominal value of 70 Pico farads.

# Appendix A

ARRL custom test circuits

# Keying Generator

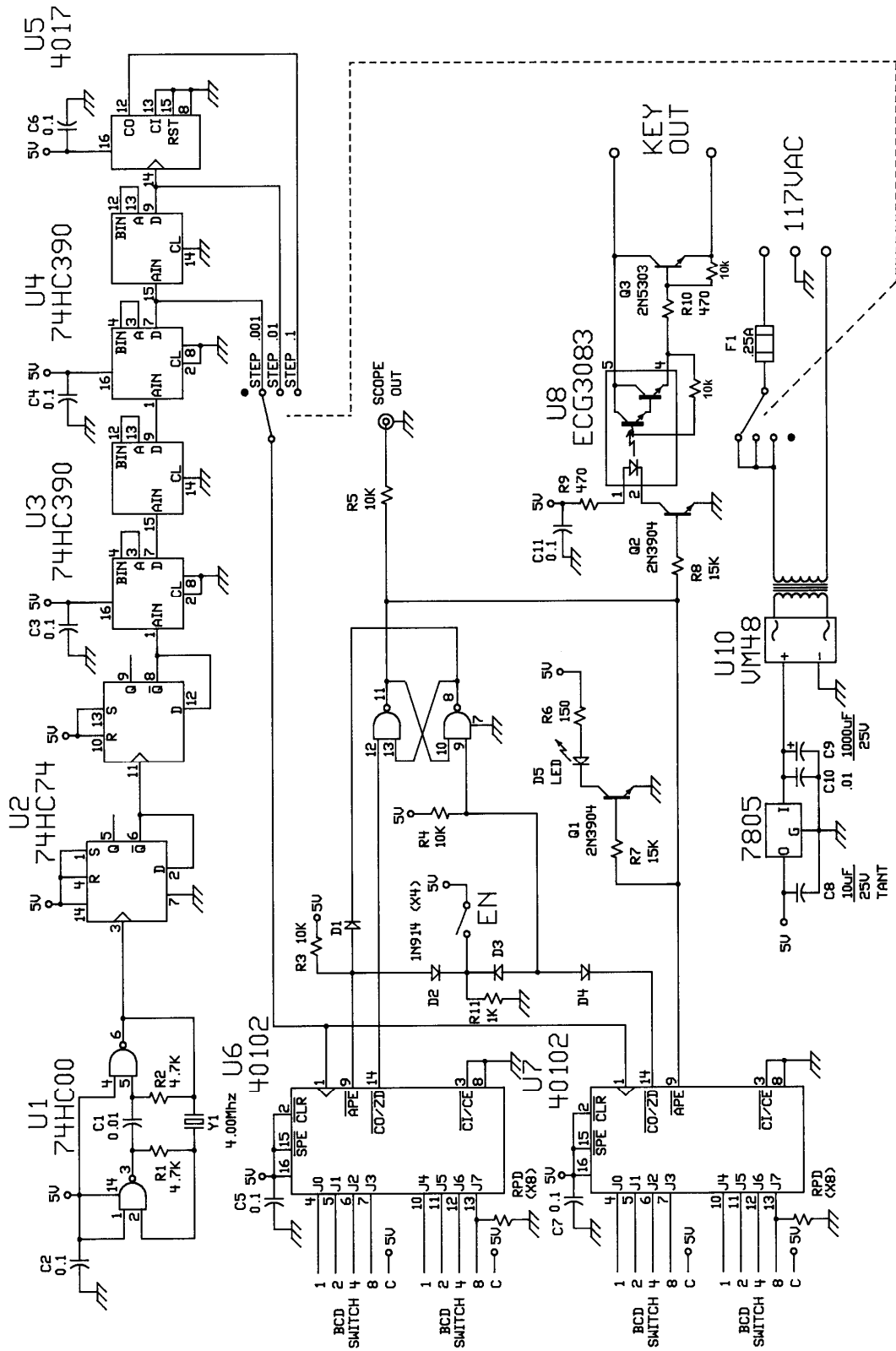

# Two-Tone Audio Generator





Exterior view of the two-tone audio generator.

## A TWO-TONE AUDIO GENERATOR

The audio frequency generator shown above makes a very convenient signal source for testing the linearity of a single-sideband transmitter. To be suitable for transmitter evaluation, a generator of this type must produce two non-harmonically related tones of equal amplitude. The level of harmonic and intermodulation distortion must be sufficiently low so as not to confuse the measurement. The frequencies used in this generator are 700 and 1900 Hz, both well inside the normal audio passband of an SSB transmitter.

Spectral analysis and practical application with many different transmitters has shown this generator to meet all of the requirements mentioned above. While designed specifically for transmitter testing it is also useful any time a fixed-frequency, low-level audio tone is needed. Details on distortion measurement and the two-tone test can be found in Chapter 18.

### Circuit Details

Each of the two tones is generated by a separate Wein bridge oscillator, U1B and U2B. The oscillators are followed by RC active low-pass filters, U1A and U2A. Because the filters require nonstandard capacitor values, provisions have been made on the circuit board for placing two capacitors in parallel in those cases where standard values cannot be used. The oscillator and filter capacitors should be polystyrene or Mylar film types if available. Two tones are combined at op amp U3A. This amplifier has a variable resistor, R4, in its feedback loop which serves as the output LEVEL control. While R4 varies both tones together, R3, the BALANCE control, allows the level of tone A to be changed without affecting the level of tone B. This is necessary because some transmitters do not have equal audio response at both frequencies. Following the summing amplifier is a step attenuator; S3 controls the output level in 10-dB steps. The use of two output level controls, R4 and S3, allows the output to cover a wide range and still be easy to set to a specific level.

The remaining op amp, U3B is connected as a voltage follower and serves to buffer the output while providing a high-impedance load for the

step attenuator. Either a high or a low output impedance can be selected by S4. The values shown are suitable for most transmitters using either high- or low- impedance microphones.

### Construction and Adjustment

Component layout and wiring are not critical, and any type of construction can be used with good results. For those who wish to use a printed-circuit board, a parts placement guide is shown on the next page. Because the generator will normally be used near a transmitter, it should be enclosed in some type of metal case for shielding. Battery power was chosen to reduce the possibility of RF entering the unit through the ac line. With careful shielding and filtering, the builder should be able to use an ac power supply in place of the batteries.

The only adjustment required before use is the setting of the oscillator feedback trimmers, R1 and R2. These should be set so that the output of each oscillator, measured at pin 7 of U1 and U2, is about 0.5 volt RMS. A VTVM or oscilloscope can be used for this measurement. If neither of these is available, the feedback should be adjusted to the minimum level that allows the oscillators to start reliably and stabilize quickly. When the oscillators are first turned on, they take a few seconds before they will have a stable output amplitude. This is caused by the lamps, DS1 and DS2, used in the oscillator feedback circuit. This is normal and should cause no difficulty. The connection to the transmitter should be through a shielded cable.

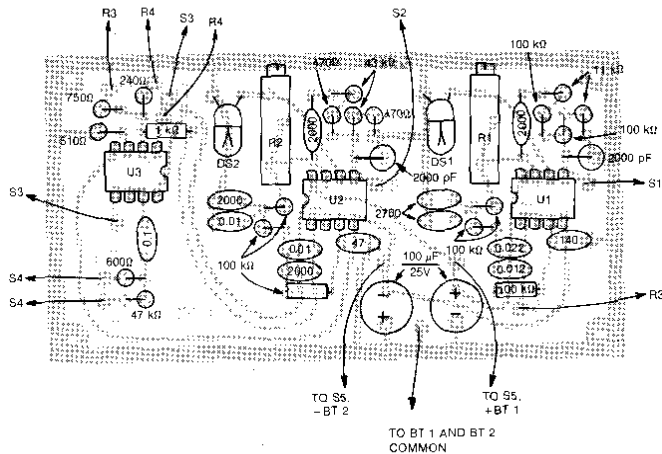

Parts-placement diagram for the two-tone audio generator, shown from the component side of the board.

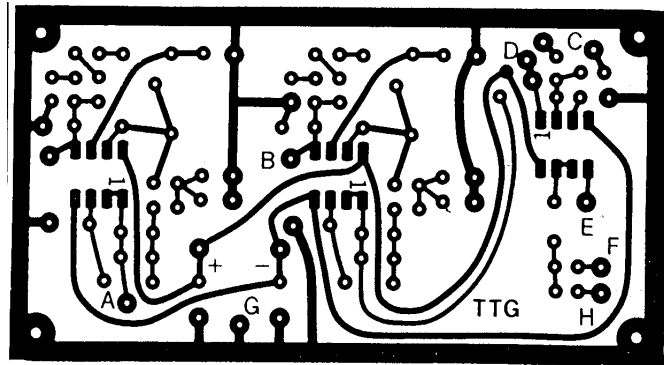

Printed-circuit board etching pattern, shown from the foil side of the board.

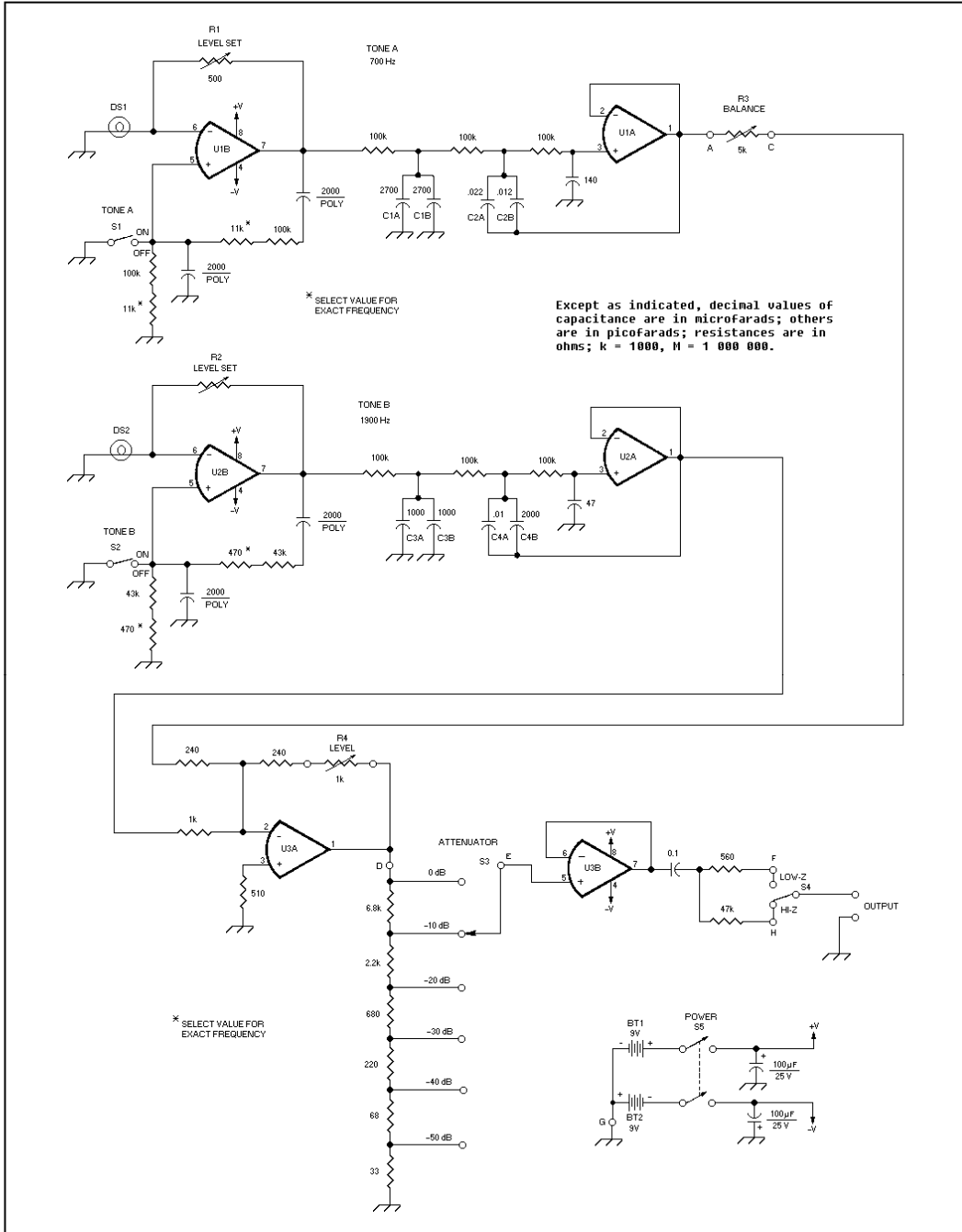

Schematic diagram of the two-tone audio generator. All resistors are 1/4-W carbon film.

BT1, BT2--9V Alkaline.

C1A, B--Total capacitance of 0.0054  $\mu\text{F}$ ,  $\pm 5\%$

C2A, B--Total capacitance of 0.034  $\mu\text{F}$ ,  $\pm 5\%$

C3A, B--Total capacitance of 0.002  $\mu\text{F}$ ,  $\pm 5\%$

C4A, B--Total capacitance of 0.012  $\mu\text{F}$ ,  $\pm 5\%$

DS1, DS2--12V, 25mA lamp.

R1, R2--500 $\Omega$ , 10-turn trim potentiometer.

R3--500 $\Omega$ , panel-mount potentiometer.

R4--1k $\Omega$ , panel-mount potentiometer.

S1, S2--SPST toggle switch.

S3--Single-pole, 6-position rotary switch.

S4--SPDT toggle switch.

S5--DPDT toggle switch.

U1, U2, U3--Dual JFET op amp, type LF353N or TL082.





## Low Noise Amplifier

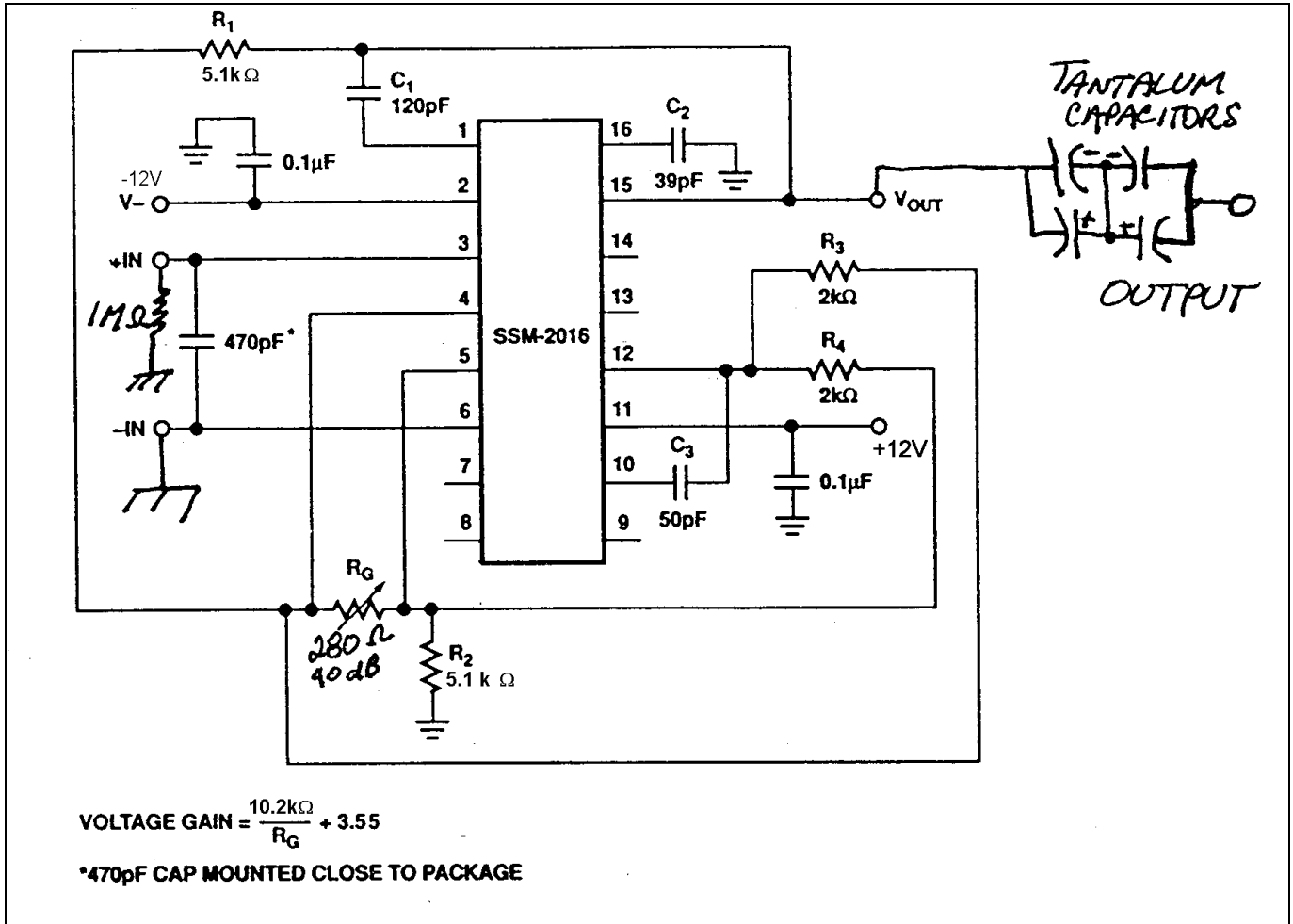

### Audio Low Noise Amplifier Calibration Procedure

- Connect the output of the Marconi 2041 RF signal generator to the input of the HP-6536E Spectrum Analyzer.
- Set the signal generator to -50 dBm at a frequency of 10 kHz (no modulation).
- Set the spectrum analyzer center frequency to 10 kHz and set the frequency span to about 20 kHz or less.
- Note the peak signal level on the spectrum analyzer display. It should be close to -50 dBm, but will not be exact. Record this level.
- Switch the input of the spectrum analyzer to the output of the audio low noise amp (LNA).
- Set the signal generator level to -99.5 dBm and switch the output of the generator to the input of the LNA.
- Observe the signal level on the spectrum analyzer display and adjust the gain trimmer on the LNA for the same signal level as observed previously. The gain will now be the correct value of 49.5 dB.



# BER Test Box

# Measuring 9600-Baud Radio BER Performance

DSP techniques make testing a G3RUH-compatible radio easy.

[Reproduced from March 1995 QEX]

By Jon Bloom, KE3Z  
225 Main Street  
Newington, CT 06111  
email: jbloom@arrl.org

One of the jobs of the ARRL Lab is to test the performance of equipment sold to amateurs. With the new crop of 9600-baud radios coming out, we had to develop a technique for testing their performance. The best way to test the performance of a radio used for digital communication is, by far, to test the bit-error rate (BER) that the radio provides under various conditions. BER is a conceptually simple metric that answers the question: How many of the bits get through correctly when a data stream is passed through the system?

The system we developed uses a Texas Instruments DSP Starter Kit (DSK) board that includes a TMS320C26 processor. Figs 1 and 2 show the circuitry of the BER test box built in the ARRL Lab. The DSP generates a test signal that is passed through the system under test. For receiver testing, the signal modulates a low-noise FM signal generator that feeds the radio being tested. The demodulated output of the radio goes to the DSP input so that the demodulated signal can be compared to the transmitted signal. To test transmitters, the DSP output test signal is applied to the modulation input of the transmitter under test. The transmitter RF output is attenuated to a low level, then applied to the Lab-built test box where it is mixed with an unmodulated signal from a signal generator. The resulting IF signal is demodulated by a low-distortion demodulator, and the demodulated signal is routed to the DSP input for comparison with the generated signal.

## G3RUH Signals

The 9600-baud system used for amateur packet radio, both terrestrially and via the UoSat packet satellites, uses signals handled by the G3RUH modem design. In this system, the binary data stream coming out of a TNC is first "scrambled" to remove any dc component of the signal. Scrambling, which has nothing to do with encryption or data hiding, is simply encoding that ensures that, on average, there are as many 1-bits in the data stream as there are 0-bits. The average voltage of the data signal is thus constant. The scrambled data signal is then used to generate shaped pulses. The shaped-pulse signal is what is applied to the modulation input of the FM transmitter.

On reception, the shaped-pulse signal is filtered and limited, to recover the scrambled data stream. A clock-recovery circuit generates a clock signal that is synchronous with the incoming data. Using this clock, the modem descrambles the data stream, with the end result being a binary data signal identical to the transmitted data signal.

Since our test system has to generate and receive signals like those of the G3RUH modem, some discussion of the pulse shaping used is necessary. The general problem to be solved when sending digital data using FSK is to limit the bandwidth of the baseband (data) signal before applying it to the modulator. But you have to be careful how you do that.

When we limit the bandwidth of a pulsed signal, we necessarily stretch the pulses in time. That is, a signal that is band limited cannot also be time limited. That means that in limiting the bandwidth, we cause each pulse to overlap adjacent pulses. In theory, each pulse overlaps all of the other pulses, but as you go further away in time from a particular pulse, its amplitude gets smaller and smaller.

So, we need to find some way of allowing the pulses to overlap their neighbors without interference. One approach to doing so is to shape the pulses so that, while each pulse does overlap its neighbors, the amplitude of that pulse is zero at the center of each of the other pulses. That way, we can sample the signal at the center of each pulse period and see only the signal from the current pulse; none of the other pulses contributes any amplitude to the signal at that time.

The spectrum of one pulse that has these characteristics is straightforward. It is flat from 0 Hz out to some chosen frequency, then rolls off with a cosine-shaped curve, reaching -6 dB at one-half the baud rate.<sup>1</sup> It continues curve, reaching -6 dB at one-half the baud rate.<sup>1</sup> It continues rolling off with this cosine curve until it reaches zero. In the G3RUH system, the spectrum begins rolling off at 2400 Hz, reaches the -6-dB point at 4800 Hz and reaches zero at 7200 Hz.

In the time domain, the pulse shape that results from such a spectrum has a maximum at the center of the bit period, then decreases in amplitude as we move away from the center of the bit. The pulse signal goes negative, passing through zero at the center of the preceding and following bits. As we go farther away in time from the bit center, the signal alternates between positive and negative values, always passing through zero at the center of each bit. There are other spectra that have pulse shapes that reach zero at the center of all the other pulses, but the benefit of the raised-cosine spectrum is that the pulse amplitude falls off rapidly with time. This is important because any amplitude or phase distortion present in the system is likely to cause the zero-crossing points of the pulse to shift in time, causing ISI. Since the amplitude of the pulse is small near the center of other pulses, the potential for harmful ISI is also small.

Since each bit of the shaped-pulse signal now extends across multiple bit periods -- both preceding and following bits periods - - we must take this into account in generating our signal. And, since this is DSP, what we are generating is a sampled version of the signal. What we must end up with at any sample is a signal that comprises a component from the current bit, preceding bits and following bits. Theoretically, we need components from all of the bits in the data stream, but the amplitude of each pulse falls off so rapidly that only a few successive bits need be used to generate any given sample. In this system, we chose to include components of the current bit and the four preceding and four following bits.

Note that only 1-bits contribute to the signal; 0-bits generate no pulse. If we were to send a continuous stream of 0-bits, we'd get no pulses at all. (Of course, the scrambler circuit ensures that will never occur in a real transmitted data stream.) So, for each sample we need to add up the contribution of the current bit and the contributions of eight other bits, some of which may be 0-bits that make no contribution. The contribution of a particular preceding or following 1-bit is the amplitude of its pulse at the present time. To keep things simple, we use a sampling rate that is a multiple of the baud rate -- and thus a multiple of the pulse rate.

The method used to implement this pulse forming is an FIR filter. The impulse response of the filter is simply the samples that comprise a single shaped pulse, extending over nine bit periods. Our sampling rate is four times the bit rate, so the impulse response is  $4 \times 9 = 36$  samples long. A Mathcad 5.0 worksheet, shown in Fig 3, calculates the impulse response.

If we feed a single sample of amplitude 1 into the filter, preceded and followed by 0-amplitude samples, the resulting output will be a single copy of our shaped pulse, as shown in the Mathcad graph in Fig 3. To generate our data stream, we input the present data value (1 or 0) at one sample, follow it with three samples of 0, then input the next data value. At any time, the FIR filter contains zeroes in all except (possibly) 9 locations, representing the 9 successive data bits. The output of the filter at any sample time comprises components of 9 data pulses, which is what we want for our shaped-pulse signal.

Now that we know how to generate the shaped-pulse signal from a data stream, we need to think about how to generate the data stream itself. We want to generate a data stream that mimics the scrambled signal of the G3RUH modem. The scrambler in the modem is a tapped shift register with feedback. The logic equation for this circuit is:

$$y = x_0 + x_{12} + x_{17}$$

where  $y$  is the output of the scrambler,  $x_0$  is the current input bit,  $x_{12}$  is the 12th previous input bit and  $x_{17}$  is the 17th previous input bit. Generating the test data stream is done by making  $x_0$  always a 1, implementing a shift register in software, and calculating  $y$  for each new data bit -- once every four samples. Note that this is essentially the same signal generated by the G3RUH modem in its BER test mode.

### Counting Bit Errors

Having generated a test signal, we now need to consider how to compare the signal coming back from the system under test to the signal we transmitted. In passing through the tested system, the signal will be delayed by some amount, and the amount of delay will vary from one system to another. What we need to do is determine what the system delay is, then remember what our transmitted signal was that far back in the past in order to compare it to the samples of the received signal. But we are only interested in the value of the received signal at one time during each bit period: the center of the bit.

The DSP software handles this need using a two-step delay process. First, the operator will tell the DSP system how many samples of delay there are between the transmitted and received signals. Of course, the system delay is not likely to be kind enough to let the center of the received bits fall right onto one of our samples -- there are only four samples per bit, after all. So, the second step is to adjust the phase of the DSP's transmit and receive sample clocks. The combination of these two techniques lets us adjust the DSP's delay with fine resolution.

This calibration procedure is performed using a dual-channel oscilloscope. One channel is connected to the sync signal from the DSK, the other channel is used to display the demodulated signal that is being fed into the DSK input. The operator first commands the DSK to generate a calibration signal. The DSK does so by passing a single 1-bit through the FIR filter described previously, followed by 0-bits. The 1-bit is repeated every 72 samples, resulting in a single shaped pulse every 2 ms. The oscilloscope is triggered on the sync signal and set for 0.2  $\mu\text{sec}/\text{div}$ . The operator then sends commands to the DSK to alter the number of samples of delay between the transmitted and received signals.

The sync signal, a short pulse, is output during the sample the DSK believes to be the center of the received bit. Thus the operator simply adjusts the delay value, which causes the received signal trace on the oscilloscope to move relative to the sync pulse. When the sync pulse is aligned with the shaped pulse of the received signal (Fig 4), the DSK is at the proper sample-delay value.

To achieve final calibration, the DSK clock phases must be adjusted to take into account the part of the system delay that is less than one sample period long. This is done by commanding the DSK to output its test signal and switching the oscilloscope to 10  $\mu\text{sec}/\text{div}$ . Now the oscilloscope displays a sync pulse at the right side of the screen, along with the eye pattern of the received data (Fig 5). The proper sampling point of the bits is the point where the eye is most "open." However, there is a 14- $\mu\text{sec}$  delay in the DSK system between the actual sampling point and the sync pulse. Thus, the operator commands the DSK to step its clock phase until the center of the eye leads the sync pulse by 14  $\mu\text{sec}$ . This is not a hugely critical setting -- a few-microsecond error isn't normally detectable in the measured BER. The delay does have to be in the ballpark, however.

There is one more detail to consider during calibration. Depending on the system being tested, the received signal may be inverted from the transmitted signal; the positive-going pulses we sent may now be negative-going. If this is the case, the DSK will count all the correctly received bits as bad and all the bad bits as correct. So, the DSK supports a user command to invert the sense of the received data. The polarity of the received signal is most easily seen during the first calibration phase (Fig 4), and if the pulse is seen to be inverted then, the DSK's "invert" command should be issued. That will cause no difference in the displayed signal, but the DSK will know "which way is up."

## DSP Program Operation

The DSP program used to perform BER measurements is called DBERT. The object file, DBERT.DSK, is downloaded into the DSK from the host computer. Once DBERT is running, it communicates with the host computer via the DSK's serial port. The serial I/O communication mechanism was described in a previous article.<sup>2</sup> When serial I/O is occurring, the DSP interrupts must be disabled. This keeps the DSP from executing its signal-processing operations during serial I/O. For that reason, DSK operation is controlled by the host computer using a command-response sequence: The host sends a command to the DSK, the DSK executes that command -- including any needed signal processing -- and reports completion of the command back to the host, if needed. Each command to the DSK from the host is a single ASCII character. Some commands result in the DSK needing to send data back to the host. In that case, once the command is completed by the DSK, it sends the data back to the host via the serial interface. Table 1 lists the commands supported by the DBERT program.

Because the DSK has to stop its signal I/O while communicating with the host, there is a potential problem in taking a measurement. When the DSK begins generating the test signal, it is possible that the system being tested will exhibit a response to the start-up transient from the DSK that invalidates the result. So, the BER test signal is started and the DSK waits 20,000 samples (about a half-second) before starting to sample the received signal.

We wanted to be able to test at consistent signal-to-noise ratios in order to establish reference levels for comparing different radios to one another. Since each unit will exhibit a unique sensitivity, we needed some way of adjusting the input power level to get a fixed output signal-to-noise ratio. The solution was to include a SINAD measurement function in the DBERT program. When the DSK receives the SINAD command from the host, it generates a 1-kHz sine wave.

About a half-second after it begins generating the sine wave, the SINAD measurement software begins sampling the input signal. It then takes 8192 samples for measurement. Each measured sample is squared and added to a running sum (the signal-plus-noise value). The samples are also run through a narrow 1-kHz IIR notch filter that removes the 1-kHz test signal, leaving only the noise. The output samples from this filter are also squared and added to a (separate) running sum (the noise value). After 8192 samples have been processed, the two 32-bit sum values are returned to the host computer. The host can then calculate the SINAD by expressing the ratio of the signal-plus-noise value to the noise value in dB. A more detailed description of this technique was published in an earlier QEX article.<sup>3</sup>

The analog I/O of the DSK is performed by a TLC32040 integrated analog subsystem. This chip includes a 14-bit D/A, 14-bit A/D, sample-clock generator and input and output programmable switched-capacitor filters (SCF). The TLC32040 is driven by a 10-MHz clock produced by the processor chip. The frequency of this clock, in combination with the programmable dividers in the analog chip, determines the available sampling rates. The design of the BER test software calls for a 38,400 sample-per-second (sps) rate. Unfortunately, this exact rate isn't possible with the 10-MHz clock. The nearest available rate is approximately 38,461.5 sps. This translates to a 0.16% error in the speed of the test signals, which is negligible in the context of BER measurements. However, this error is sufficient to make the test signal unreadable by a G3RUH modem since the clock-recovery loop in that design has a very narrow lock range. I discovered this early on in the development of this system. To check that the problem was in fact the speed difference and not some problem with the signal I was generating, I temporarily removed the 40-MHz master oscillator on the DSK board -- from which the 10-MHz clock is derived -- and connected a signal generator to the clock input through a Schmitt trigger inverter. By setting the signal generator to generate exactly the clock frequency needed to get a 9600-baud signal, I found that the G3RUH modem was quite happy to consider my BER test signal a proper one.

Another problem with the TLC32040 is that the input SCF is a band-pass filter that normally cuts off at about 300 Hz. While the filter cut-off frequency is programmable, it can't be set anywhere near the very low frequency needed for this application. So, the DBERT program configures the TLC32040 to operate without its input filter. This requires that an external antialiasing filter be added. As shown in Fig 2, and described in more detail later, an SCF that cuts off at 10 kHz was added to the BER test box to fill this need. The final characteristic of the TLC32040 to note is that it includes no internal  $\sin x/x$  correction -- not surprising in a chip with a programmable sample rate. Fortunately, with a sampling rate of 38400 Hz and signals of only up to 7200 Hz, the  $\sin x/x$  roll-off at the upper end of the signal spectrum is only about 1/2 dB. Still, this seems worth correcting. The TLC32040 data sheet describes a first-order IIR filter that can be used to perform this correction. The Mathcad worksheet of Fig 6 shows the calculation of the coefficients of this  $\sin x/x$  correction filter, which is implemented in the DBERT program. Fig 6 also shows the predicted output response both before and after the correction, as well as the estimated group delay of the correction filter.

As noted, the calibration procedure requires a sync pulse. The DSK has no uncommitted output signal lines usable for outputting a pulse, so DBERT outputs the sync pulse on the serial data output line. Since the sync pulse is less than a microsecond long, this won't usually bother the serial I/O chip of the host computer. (We did find one computer that was occasionally confused by the presence of the sync pulse.) The RS-232 signal is available on one of the DSK's expansion connectors. A 10-k ohm resistor connected to this point brings the sync signal out to the front panel of the BER test box. The presence of the resistor protects the RS-232 line from accidental shorting or application of another signal.

## Host Application Software

We used two different programs. One, which we won't cover in detail here, manages the Lab's computer-controlled signal generator for stepped BER measurements at various signal levels and frequencies. The other program, BERT.EXE, is a C program that communicates with the DSK under operator control. Communication with the DSK is normally performed at 19,200 baud, although slower speeds can be used. To ensure that no serial overruns occur, BERT uses interrupt-driven serial I/O.

The BERT program is quite straightforward. It accepts keyboard commands from the operator and sends them to the DSK. The command set is the same as that of DBERT -- BERT just passes these commands through to the DSK -- with a couple of additions. Also, BERT "knows" about those DSK commands that generate a response from DBERT. When such a command is given, BERT waits for the response from the DSK, then converts the incoming serial bytes to binary values. In the case of BER test values (commands 4 and 5), it prints out the reported number of errors and the BER, calculating the latter based on the number of bits the DSK was commanded to use in its test. For the SINAD command (S), BERT computes and prints the SINAD and the distortion percentage using the values returned by DBERT.

The DBERT program can perform BER tests using 10,000 samples or 100,000 samples. The BERT program also provides a 1-million sample BER test (the 6 command), which it performs by commanding the DSK to perform a 100,000-sample BER test 10 times. BERT sums the values from each of these tests to get the final result. As each BER test result is returned from the DSK, BERT prints the running total of samples, errors and BER. The L command performs the same function, except that it stops if 100 or more total errors have been reported. If the operator selects the calibrate (C), idle (I), sine-wave (N) or quiet (Q) commands, BERT remembers the selected command. Whenever a BER or SINAD test command is performed, BERT waits for that command to complete, then sends the appropriate command to place DBERT in the most recently selected mode from among those listed.

### **BER Test Box Hardware**

The BER test box contains several op-amp amplifiers used to keep the input signals within the range of the TLC32040 analog input. The box also contains a mixer and a demodulator, shown in Fig 2, designed by ARRL Lab Engineer Zack Lau, W1VT. To test transmitters, the transmitter output is attenuated with a high-power attenuator down to a level that the SBL-1 mixer, U3, can handle. The LO input of the SBL-1 is driven by a +7-dBm signal from a signal generator set to a frequency 373-kHz below or above the transmitter frequency. The output from the SBL-1 passes through a low-pass filter that removes the sum frequency, leaving only the 373-kHz difference frequency. This signal is applied to an NE604 FM IF chip that contains a limiter, IF amplifier and quadrature FM demodulator. The frequency at which the demodulator operates is set by L1 and its associated silver-mica capacitor. When Zack built this circuit, the components he used just happened to fall at 373 kHz. If you reproduce the circuit, it's likely that your copy will work at a slightly different frequency. This shouldn't present a problem; the exact operating frequency isn't critical.

Since the NE604 operates from a single 5-V supply, its output is a positive voltage. This signal is fed into U4A, which amplifies the signal and also removes the positive offset, so that the result is zero volts when the input signal is at 373 kHz. U4B amplifies this demodulated signal or an external input signal (usually the output of a receiver being tested) with adjustable gain. The signal is finally filtered in an MF4 4th-order Butterworth low-pass SCF, U6, that acts as the antialiasing filter for the DSP input. The cut-off frequency of U6 is determined by its input clock, with the clock being 50 times the cutoff frequency. In our test set, this clock is supplied by an external function generator, but it could as easily be provided by a crystal oscillator and divider chain.

### **Interpreting BER Measurements**

Bit errors are (or should be) due mainly to corruption of the signal by noise. Thus, they should be random. That being the case, if you make the same measurement several times, you are likely to get different results each time. But the more bits you send through the system, the more the effect of noise is averaged and the more consistent the measurements will be. That raises the question: How many bits do you need to use to get a valid result? The answer to that question depends on what you mean by "a valid result." The more bits you use, the closer your measurement will be to the "true" BER you would get if you sent an infinite number of bits through the system. Since sending an infinite number of bits through the system is a little, well, impractical, we need to come up with some guidelines for selecting a finite number of bits to use.

Unfortunately, in order to do that we have to make some assumptions about the character of the noise in the system. Fortunately, the assumptions we make hold up pretty well for real systems. (There's nothing new about this; we make assumptions about the character of system noise all the time. For example, when we relate noise to system bandwidth we often assume that the noise is uniformly distributed across the spectrum of interest.)

What we find is that with a given number of bits in the sample set, and a given number of errors within those bits, we can establish a confidence interval. The confidence interval tells us how likely it is that our measurement is within some specified factor of the "true" BER. For example, we might find that our measurement gives us an 80% confidence that the value is within a factor of 3 of the true BER. The end result is that we can get as good a measurement as we want if we are willing to wait for enough bits to go through the system. Of course, at a low BER we don't get many errors, so we need to send a lot of bits!

What's interesting about the confidence interval is that it depends on the number of errors detected. Suppose you made two BER measurements. If for the second measurement you double the number of bits sent and get double the number of errors, you end up with the same BER but a higher confidence. On the other hand, if you double the number of bits but measure the same number of errors (you're measuring at a lower noise level, for instance), you get a lower BER but the same confidence interval. What that means is that all we need to do is to ensure that we have at least the number of errors needed to establish the desired confidence interval.

There are two useful sets of numbers we've used here in the ARRL Lab for our BER testing. If you measure 10 bit errors, you are 95% sure that you are within a factor of about 2 of the true BER. And if you get 100 bit errors, you are 99% sure that you are within a factor of about 1.3 of the true BER.<sup>4</sup> If you look at a curve of BER versus signal-to-noise ratio, you'll find that a factor-of-2 difference in BER occurs with a fraction of a dB change in signal-to-noise ratio. That suggests that a measurement that results in 10 bit errors is a pretty good one, and a measurement that results in 100 bit errors is a very good measurement. That's why the L command exists in the BERT program. It pops 100,000 bits at a time through the system, stopping when 100 or more errors have been reported -- because continuing to measure more bit errors is a waste of time -- or when 1 million bits have been sent. Using a million bits means that a BER of  $1 \times 10^{-4}$  (100 bit errors) or worse can be measured with great accuracy, and a BER of  $1 \times 10^{-5}$  (10 bit errors) can be measured with decent accuracy. Of course, if you have time on your hands you can measure a BER of  $1 \times 10^{-6}$  by sending 10 million bits through the system. (That takes over 17 minutes at 9600 baud!)

### Conclusion

The system described here has been used to measure a number of 9600-baud radios. Some of the test results will be presented in an upcoming QST article, and future QST reviews of 9600-baud radios will include measurements made using this system. The system has proven to be effective and easy to use. I should add that we spot-checked the results obtained with this system by measuring BER using a G3RUH modem. It gave BER results that were consistently slightly better because its input filter cuts off at a lower frequency than the SCF in the BER test box, improving the signal-to-noise ratio.

The software for this system, including the source code, is available for downloading from the ARRL BBS (860-594-0306) and via the Internet using anonymous FTP from ftp.cs.buffalo.edu. The file name is QEXBERT.ZIP.

### Notes

- (1) Couch, L. W., Digital and Analog Communication Systems (New York: Macmillan, 1993), p 179.
- (2) Bloom, J., KE3Z, "Measuring System Response with DSP," QEX, February 1995, pp. 11-23.
- (3) Bloom, J., KE3Z, "Measuring SINAD Using DSP", QEX, June 1993, pp. 9-13.
- (4) Jeruchim, M. C., Balaban, P. and Shanmugan, K. S., Simulation of Communication Systems (New York: Plenum Press, 1992), pp. 492-501.

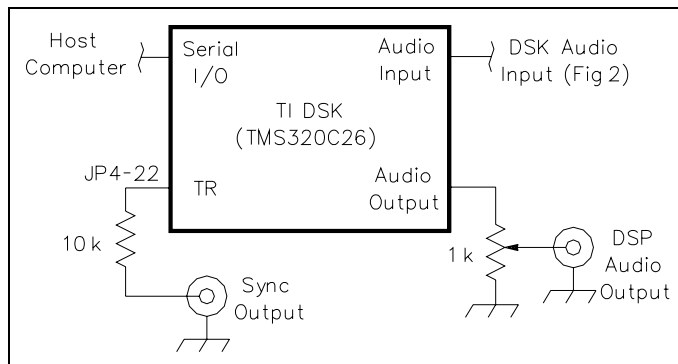

Fig. 1 -- Diagram of the BER test connections to the TI DSK.

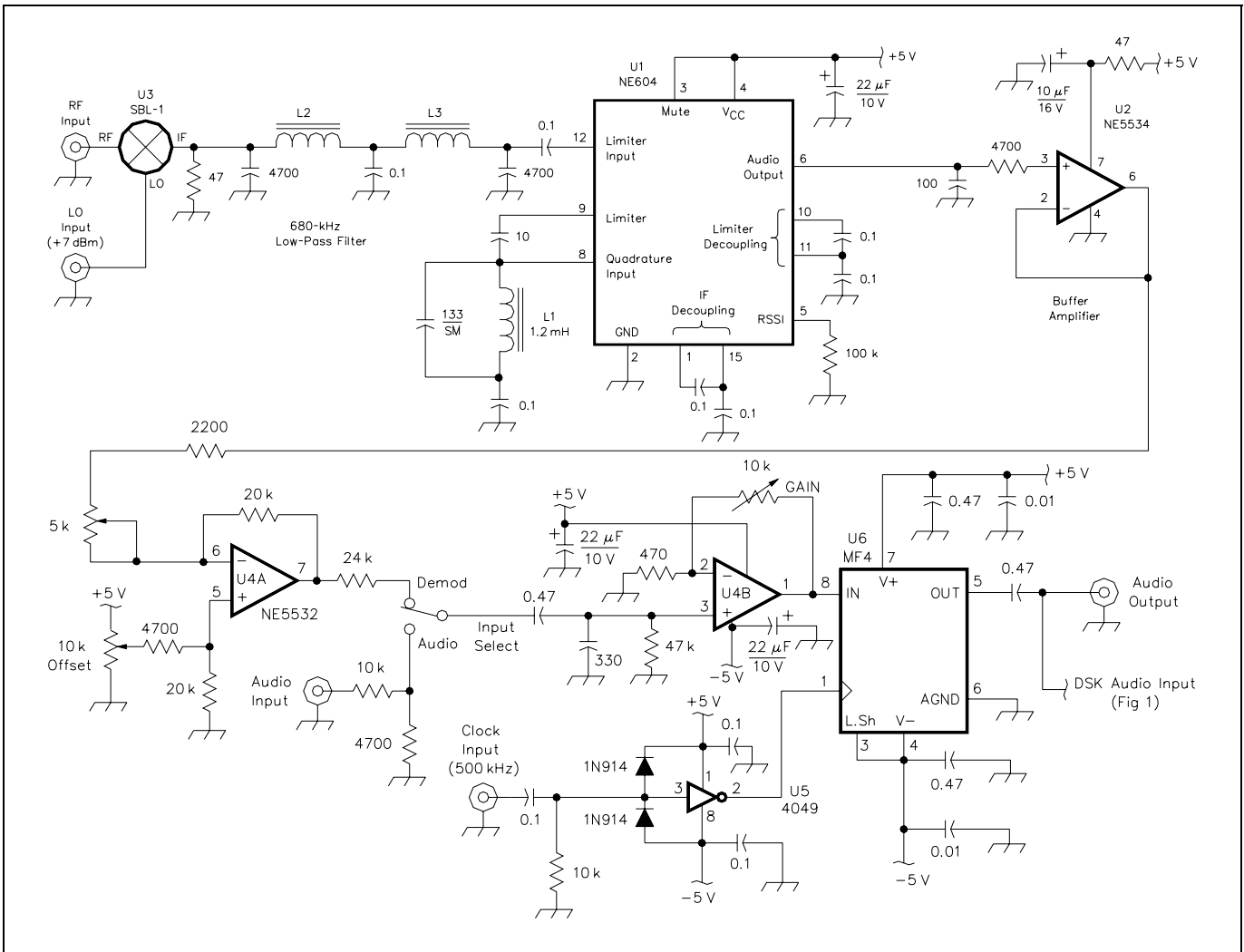

Fig 2 -- Schematic diagram of the BER test box circuit.  
 L1 -- 1.2-mH Toko 10RB fixed inductor. (Digi-Key part TK4401-ND.)  
 L2, L3 -- 41 turns #28 enam wire on a T-50-1 toroid core.

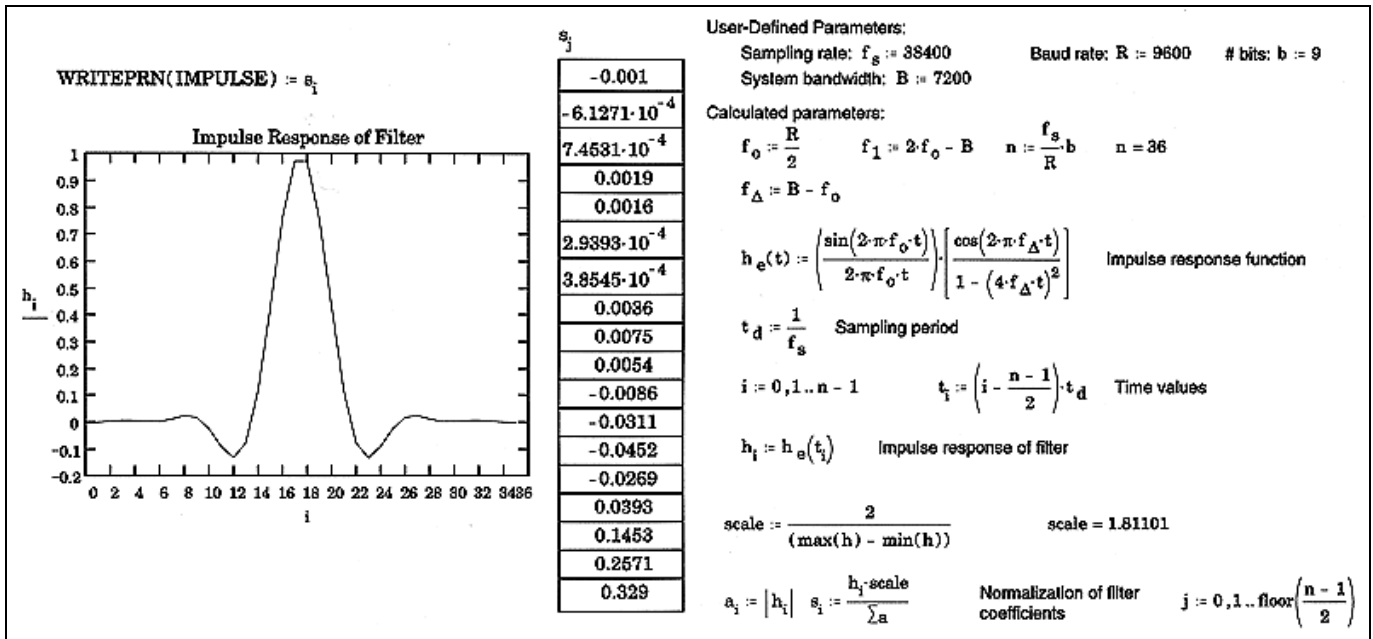

Fig 3 -- This Mathcad worksheet calculates the impulse response of the FIR filter used to generate the shaped-pulse signal.

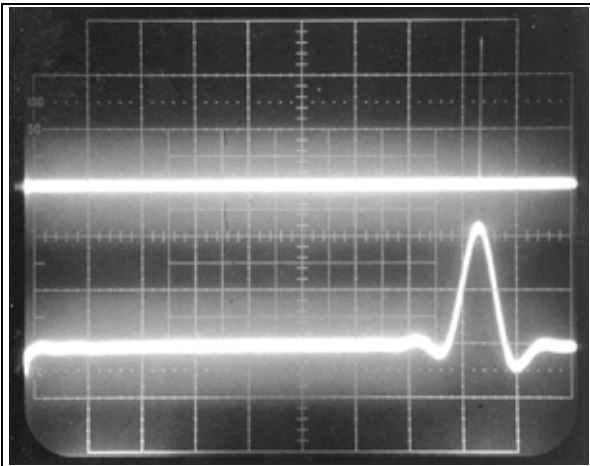

Fig 4 -- The first-phase calibration signal. When properly calibrated, the calibration signal (lower trace) is aligned with the sync pulse (upper trace) as shown. The oscilloscope is set for 0.2 μsec/div. The sync pulse is very narrow and hard to see in this photograph but shows up well on the oscilloscope screen.

Fig 5 -- Second-phase calibration uses the BER test signal and sync pulse to produce an eye pattern. The oscilloscope is set for 10 μsec/div. The center of the eye is adjusted to lead the sync pulse by 14 μsec as shown.

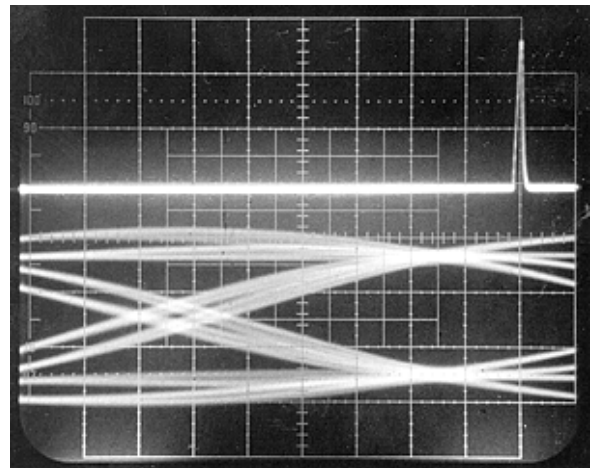
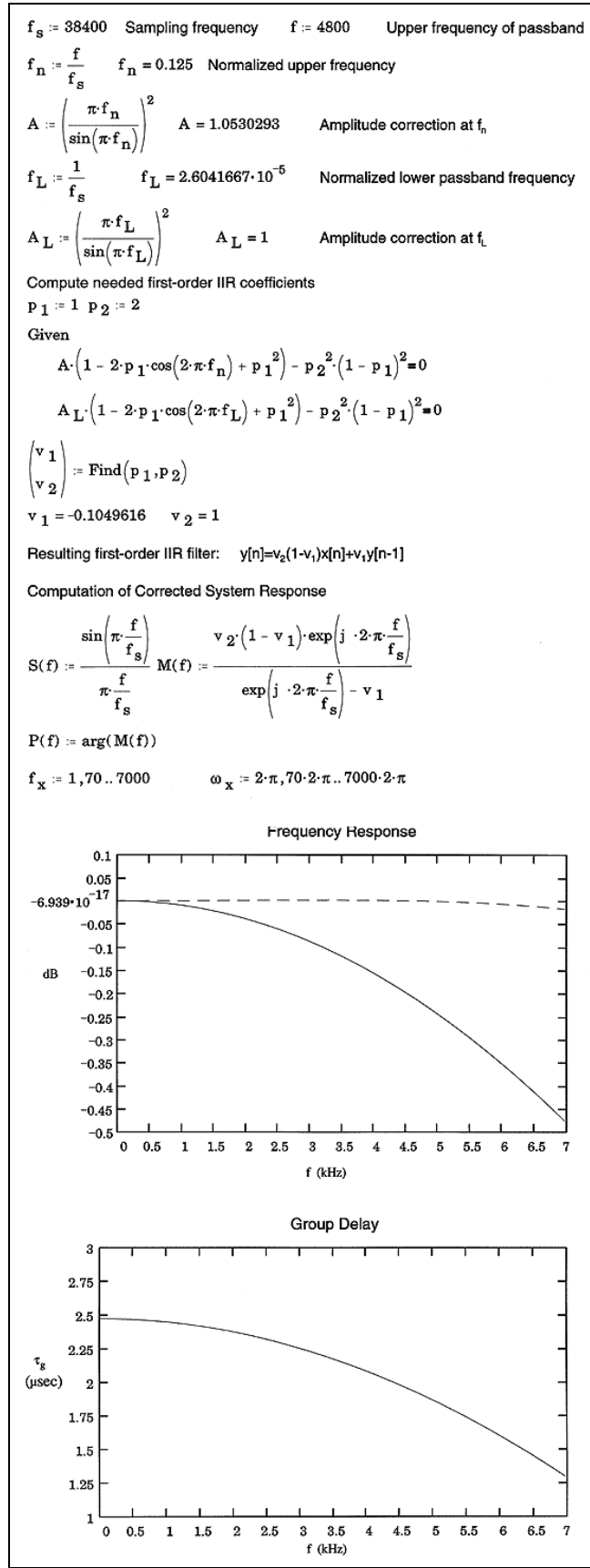

Fig 6 -- Correction of  $\sin x/x$  roll-off is performed with a first-order IIR filter having the coefficients calculated by this Mathcad worksheet.



**Update to BER Test Box:**

The ARRL BER test box was modified in March 1999 by the addition of an internal 500-kHz oscillator and high-level pseudo-random noise source. The internal oscillator was added for convenience sake, eliminating the need for an external function generator. The noise source was added to alleviate test setup difficulties imposed by transmitters that generated an excessive amount of common-mode signal.

The output of the oscillator is connected to the clock input shown in figure 2 of the QEX article on BER testing. The noise source output is resistor summed into the mixer (U3) in the same figure. A 10-turn potentiometer is used for fine control of noise output so as to achieve as close to 12 dB SINAD as possible.

The schematic of the new circuitry appears on the following page.



# Spurious-emission Limits - HF

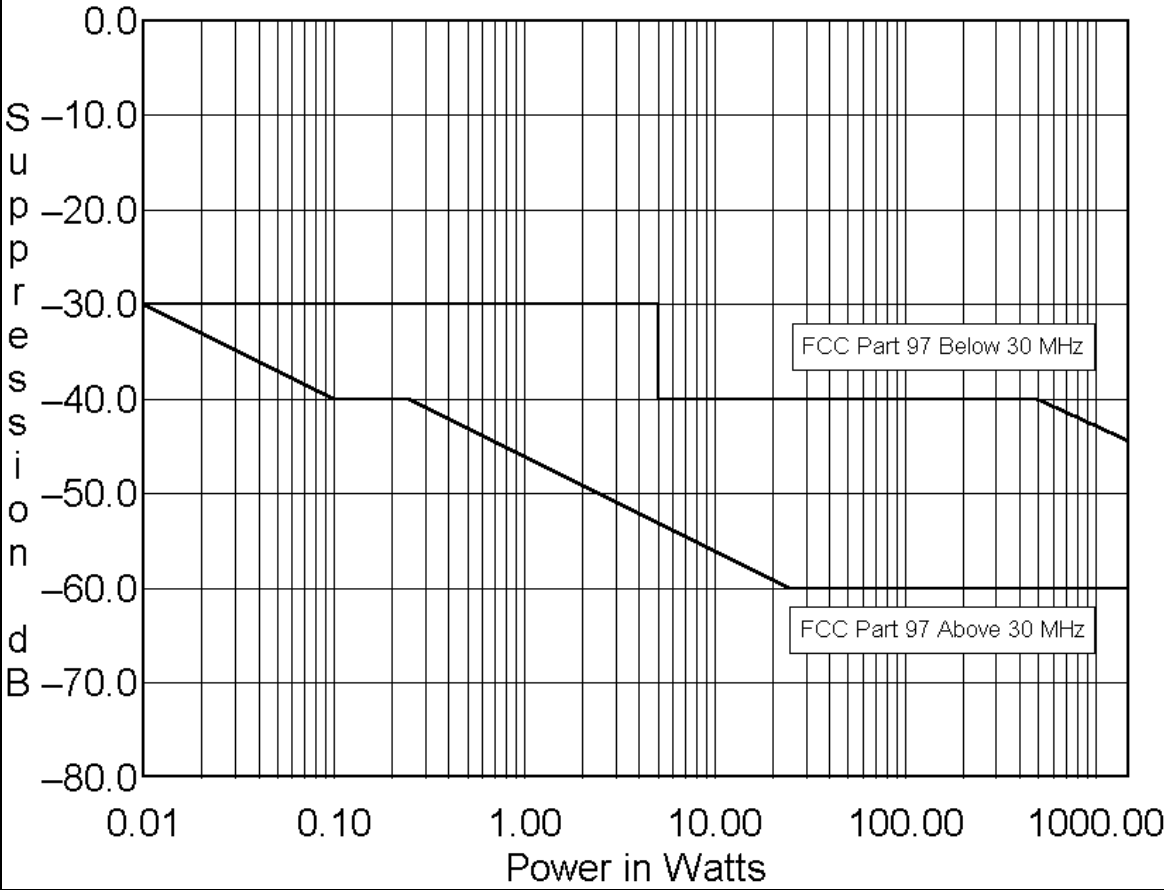

## Spurious Emission Limits - VHF

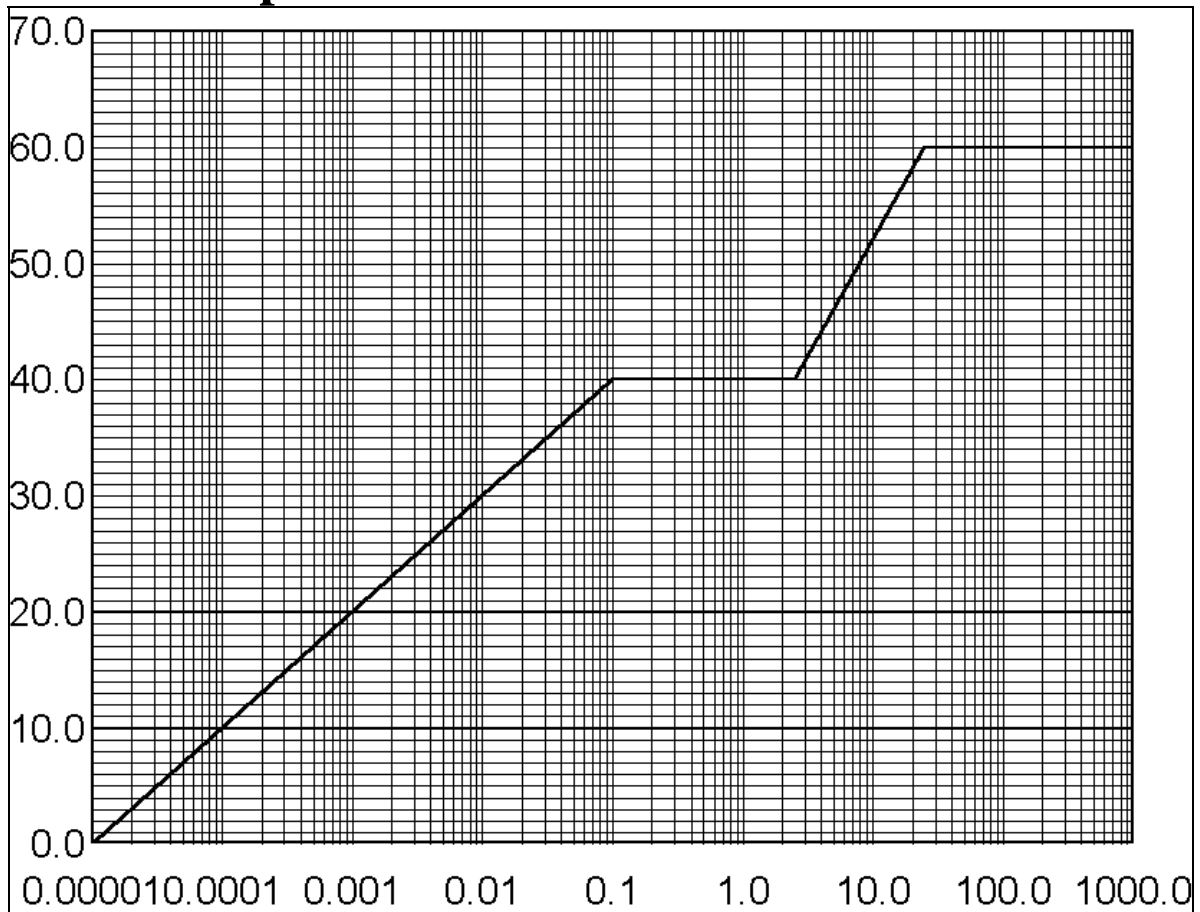

**Spurious Attenuation 30-235 MHz**  
**X=Power (Watts)**

<b>Power Level (output)</b>	<b>Attenuation</b>
<b><math>X &lt; 0.1W</math></b>	<b><math>50 + 10\text{LOG}(X)</math> dB</b>
<b><math>0.1W \leq X \leq 0.25W</math></b>	<b>40 dB</b>
<b><math>0.25W &lt; X \leq 25W</math></b>	<b><math>46 + 10\text{LOG}(X)</math> dB</b>
<b><math>X &gt; 25W</math></b>	<b>60 dB</b>

Given  $E$  and  $V$  as volts,  $P_w$  as power in watts and  $dBm$  as decibels relative to a milliwatt, the following relationships are true:

$$E = \sqrt{0.05 \times 10^{\frac{dBm}{10}}} \qquad P_w = 0.001 \times 10^{\frac{dBm}{10}}$$

$$dBm = 10 \times \text{LOG}\left(\frac{E^2}{0.05}\right) = 10 \times \text{LOG}\left(\frac{P_w}{0.001}\right)$$

$$dB\mu = 20 \times \text{LOG}(\mu V) \quad \text{To reduce } \mu V \text{ values by 10 dB, multiply by 0.3162278}$$

$$S/N \text{ in dB} = 10 \times \text{LOG}(10^{(0.1 \times (S+N/N))} - 1)$$

$$\text{Distortion (\%)} = 100 / 10^{(\text{SINAD in dB} / 20)}$$

(Assuming meter measures noise as a component of distortion)

$$\text{CodeSpeed (WPM)} = \frac{2400}{t_{dit-dit}}, \text{ where } t_{dit-dit} \text{ is the time between the rising edge of subsequent dits.}$$

$$\text{Farnsworth method code speed} = \frac{13.2}{2t_{dot} + 2t_{dash} + 3t_{ele.space}}$$

(This equation is based on the letter P in the PARIS word length standard).

### Formulas for SWR, Reflection Coefficient and Return Loss

For  $P_f$  as forward power,  $P_r$  as reflected power,  $R_l$  as return loss in decibels and  $\rho$  as reflection coefficient, the following relationships are true:

$$\rho = \sqrt{\frac{P_r}{P_f}} \qquad SWR = \frac{1 + \rho}{1 - \rho} \qquad \rho = \frac{SWR - 1}{SWR + 1} \qquad \rho = e^{-\frac{R_l}{8.68589}}$$

#### Temperature

$$+60^\circ\text{C} = +140^\circ\text{F}$$

$$-10^\circ\text{C} = +14^\circ\text{F}$$

$$-20^\circ\text{C} = -4^\circ\text{F}$$

$$-30^\circ\text{C} = -22^\circ\text{F}$$

#### Noise Floor (dBm)

$$\text{MDS (theoretical)} = -174 + \text{NF} + 10 \text{ LOG}(\text{BW})$$

Where  $-174$  dBm is the noise level of the cosmos, BW is the receiver noise bandwidth in Hertz and NF is the receiver noise figure in dB. MDS is the theoretical noise floor of the receiver, which the actual measured noise floor should be close to.