

# Getting Started

## 1.1 EXPERIMENTING, “HOMEBREWING,” AND THE PURSUIT OF THE NEW

Amateur Radio is a diverse and colorful avocation or hobby where the participants communicate with each other through the use of radio signals. The communications, which can encompass and extend beyond the planet, are often routine and predictable, but can at times be ethereal. The romance of communicating with the other side of the world blends with the joy of observing a complicated part of nature. For some of us, the wonder never disappears.

Although radio can be fun, our pragmatic society demands more than excitement when resources are used. The virtue that most often justifies our use of the radio spectrum is the growth of a proficient communications system that can be called upon in times of emergency. The examples of its use are numerous.

But, “ham” radio is more than this. It is a technical avocation of diverse educational potential. It has values that go well beyond that of a supplementary communications network.

Most radio amateurs have an interest in the technical details of the equipment they use. Historically, this was a requirement: The only way a radio amateur could assemble an operating station was to personally build his or her gear. Commercial equipment was rare, and was often prohibitively expensive. But today, high quality “ham” gear is readily available in most of the world, much of it at modest prices.

Although no longer necessary, it is still common for radio amateurs to build at least some of their own equipment. The reasons are varied and as numerous as the participants. A few purists consider building the equipment they use to be a non-optional, integral part of their hobby in the same way

that a fly fishing enthusiast would *never* consider fishing with a fly that he or she had not fabricated. The majority take an intermediate path, building parts of their radio stations while purchasing others. For some, building is an exercise in craftsmanship, an opportunity to generate equipment with an individual imprint and personality.

Common to all of these, amateur radio presents an opportunity that is rare among avocations, a chance for individual, unrestrained investigations in fundamental science and technology. This is a rarity in an age when most research and design is performed by teams of investigators within large organizations, be they universities or the engineering arms of corporations. There, the subjects chosen for investigation are often those of corporate or national interest. It is increasingly rare that a study is initiated out of simple curiosity. Fortunately, we are not so constrained within our personal investigations of radio science.

Consider an example. An experimentally inclined radio amateur envisions a new scheme for a receiver. It might be a better front end circuit, a new block diagram, or a way to realize some receiver functions with a computer. The experimenter can analyze the scheme, design an example, build a prototype, build and assemble needed test equipment, measure the receiver performance, compare it with predicted results, and use the receiver on the air. Each part of the investigation can interact with the others. All of the activity can be done without interference from other sources. The program will never be cancelled by the changing goals of an organization. Nor will it be rushed by the economic pressures of a corporate program.

The inspiration for experiment varies. In rare cases, the experimenter may feel that his or her work could lead to a new twist in the state-of-the-art, a better receiver. But more often it will just be a casual thought that “Hey, I’ve never built one of these before and I’ll learn something if I do.” The most common is an effort spurred by a need; a ham wants a rig to take along on a hiking trip when no such thing can be purchased. No matter what the origin, the experimenter can enjoy the knowledge that he or she is learning more about the subject and about the research process.

In this book we encourage all levels of what has become known as radio “homebrewing,” ranging from beginner projects to sophisticated multi-mode creations. We generally emphasize simple equipment described by primitive explanations. By *primitive*, we intend that the discussion relate to the most fundamental and basic circuit design concepts. The equipment and systems presented are themselves basic, often without the frills, bells, and whistles of commercial equipment. Some refinements will be discussed, allowing the experimenter to add those he or she needs.

This book emphasizes equipment design. Our interest is in basic circuit functions and the underlying concepts that allow them to be understood. This book is generally NOT a collection of projects for reproduction and construction. Although some of the equipment may be directly duplicated, we would prefer to have you adapt our results to fit your own needs.

This book is, in many ways, a sequel to an earlier effort, *Solid State Design for the Radio Amateur*.<sup>1</sup> That 1977 book, co-authored with the late Doug DeMaw,

WIFB, had goals similar to those outlined above, plus that of introducing solid-state methods to readers with experience limited to vacuum tube electronics. The later need has become arguable, for virtually all of our equipment is now based upon solid-state technology.

All of the circuits presented in this text have been constructed, tested, and used in practical, on-the-air situations. If there are exceptions where the authors have not

actually built an example of what is discussed, we will so state in the related text.

We emphasize the traditional communications modes of CW, the original digital mode, and SSB phone. Building little rigs and radiating and receiving continuous waves are to a radio experimenter much like playing scales and folk tunes are to a musician. They are the first things we learn, are important parts of the daily practice routine throughout life, and we

neglect them at our peril. The little rigs, and the concepts they represent, are at the core of wireless technology. It is not enough to play with them as a novice and then move on to other things; they need to be revisited over and over again at different stages of one's vocation, each time achieving a new level of mastery until finally one is probing the deepest mysteries of the art.

## 1.2 GETTING STARTED—ROUTES FOR THE BEGINNING EXPERIMENTER

### What to build:

A frequent question asked by the prospective experimenter regards an initial project or subject for pursuit. A common choice for a first project comes from a desire to extend the capabilities of an existing station. The future experimenter already has experience with on-the-air activity and a working station. He or she then wants to extend that station to new bands, improved transceiver performance, or fabricate a rig offering portability. While these goals are all worthy, they can be difficult. They may be conceptually impossible for the beginner, and impractical for the seasoned experimenter with other life commitments. A better "first" experiment may well be something that is much simpler. Several simple projects are offered later in this chapter as suitable beginnings.

### How to build it:

Another getting-started question regards the methods to use in building electronics. There are several options, all with their assets and weaknesses. A few are discussed below.

#### PRINTED CIRCUIT BOARDS

The primary construction scheme used in modern electronics is the printed circuit board (PCB). Here, pads or islands of metal are attached to an insulating material, usually epoxy-fiberglass. Wires on the parts are pushed through holes in the board and soldered to the pads, which are interconnected by printed metal runs, thus forming the circuit.

A PCB begins as a fiberglass sheet with copper laminated to one or both sides. The metal surfaces are then coated with a light sensitive "photo-resist" material. A pattern for the circuit is optically transferred to the surface and the unexposed material is washed away. The board is now placed in a solution that chemically etches some of the

copper away, leaving only those regions needed to form the desired circuit. After etching, the board is washed and drilled. Pure copper is easily corroded, so it is common to plate boards with a tin coating, forming a more stable and solderable surface. Refined boards include copper on both sides, and even plating on the inside of the holes. Industrial boards will often incorporate many layers.

Modern practice features *surface mount technology*, SMT, using small components without wire leads. The leads have been replaced with metalized regions on the parts that are then soldered directly to the board. The soldering provides physical mounting as well as electrical connection. The SMT boards are cheaper to build and usually much more dense. SMT parts can be so small that they are hard to handle without a good microscope. SMT is an interesting way to build if there is a need for really small equipment. The small size of SMT circuits often results in improved high frequency performance.

Growing SMT popularity in manufacturing means that surface mounted is the only available form for a component. Many parts don't exist in leaded forms. In some cases they can be handled by the "Surfboards" by Capital Advanced Technologies which are found in DigiKey catalogs. These are small SMT boards with an interface that will adapt to other board forms.

Circuit boards have been built in a home environment by hams for generations. The reader should review the subject in *The ARRL Handbook* to find out more about the methods. A major problem with home etched boards is the disposal of the used etchant, usually a solution of ferric chloride. Disposal practices common in the past are now questioned in this era of enlightened recycling. Although some of the projects described in this text use etched boards, few of the boards were etched in our home labs.

#### BREADBOARDED CIRCUITS

*Breadboard*, as applied to electronics, is a term from a time when early radio experimenters built their equipment on slabs of wood, often procured from the kitchen. The term remains as an industry-wide description of a preliminary experimental circuit. There are numerous modern methods that can be used to generate a one-of-a-kind circuit.

#### UGLY CONSTRUCTION

A particularly simple method was outlined in an early *QST* paper and is now known as "Ugly Construction."<sup>2</sup> Although certainly not unique, the scheme works well and continues as a recommended method. The scheme consists of the following:

1. A ground plane is established using an un-etched scrap of copper clad circuit board material.
2. Following the schematic for a circuit being built, grounded components are soldered directly to the ground foil with short leads.
3. Some non-grounded parts are soldered to and supported by the grounded components.
4. Other non-grounded components are supported with suitable "tie down points" consisting of high value resistors.
5. Once finished and working, the board can be mounted in a suitable box, hidden from view if desired, where it becomes a permanent application of the idea. Ugly construction is illustrated in **Fig 1.1**.

Casual circuit analysis allows the builder to pick the standoff resistor values. Any "high R" value resistors can be used. Usually, 1-M $\Omega$  resistors work well anywhere within RF circuits. The typical 1/4 W resistor of any value has a stray lead-to-lead parallel capacitance of about 0.3 to 0.4 pF, perhaps a little more with longer leads, and a series inductance of 3 to 5 nH.

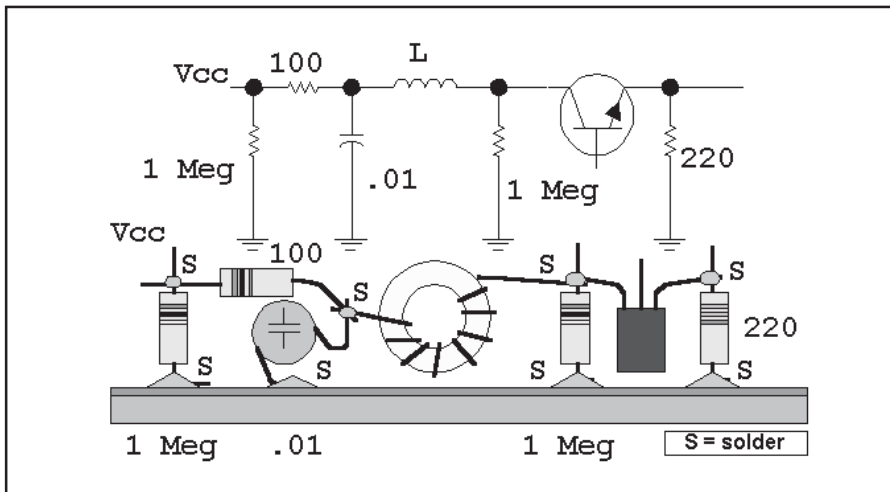

Fig 1.1—A partial circuit illustrating “ugly” construction.

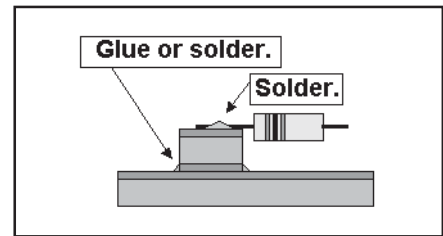

Fig 1.2—An example of “Manhattan” breadboarding.

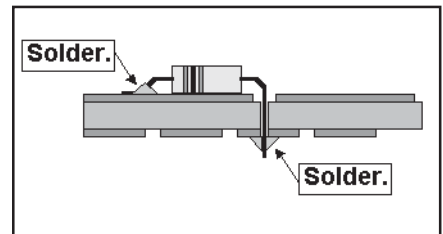

Fig 1.3—A “quasi-circuit board” scheme for breadboarding. The installed resistor here is soldered to ground and to a pad that connects to the rest of the circuitry.

Reactance is of little consequence for work up through 150 MHz or so. High  $R$  means that resistance is high with respect to the reactance of the inductance. We sometimes use  $R$  values as low as 10 k $\Omega$ . It is often surprising just how few standoff resistors are needed in an ugly breadboard.

The greatest virtue of the ugly method is low inductance grounding. Any construction scheme that preserves this grounding integrity will work as well. Picking a method is a choice that the builder has, a place where he or she can develop the methods that work best.

Integrated circuits can be placed on an ugly board with leads sticking up, “dead bug” style. There is little need to glue the chips down, for components and wires will eventually hold them in place. Grounded IC leads are bent and soldered directly to the foil.

Some builders prefer to maintain ICs with the IC label facing upward, allowing later inspection. They then bend all leads out in a “spread eagle” format.

We have never had a problem with ugly equipment being less than robust. Many of our ugly rigs have been hauled through the mountains of the Pacific Northwest in packs without incident. An outstanding example, the work of a friend, is the W7EL Optimized QRP Transceiver, a rig that has traveled around the world in suitcases and packs.<sup>3</sup> Few if any standoff resistors were used in that rig.

### MANHATTAN BREADBOARDING

Several other construction schemes offer similar grounding fidelity, including those where small pads of circuit board material are glued or soldered to the ground foil. These pads then have components soldered to them. We have found this

method to be especially useful for slightly massive components such as floating, non-grounded, trimmer capacitors. The specific glue type has little impact on circuit performance. Variations of this method have been called “Manhattan Construction,” and can be mixed with other breadboarding schemes. The reader can find numerous examples on the Web on sites dealing with QRP experiments, as well as in Fig 1.2.

The proponents of Manhattan Construction often use small round pads that are glued to a ground foil with epoxy or similar glue. The pads are placed so that all components are parallel to board edges and close to the ground foil. This produces an attractive board resembling a commercial, PC board. This does not seem to compromise performance.

With traditional ugly construction, parts can be moved about to make room for another stage. In the extreme, an entire circuit can be lifted and moved, a stage at a time, to another board.

A primary virtue of a bread-boarding scheme is *construction speed and flexibility*, especially important when the primary purpose of building gear is information about circuit behavior.

Some folks prefer to rebuild a circuit after a breadboarding phase, replacing an ugly prototype with a more permanent, production-like version. These efforts take additional time and rarely produce performance superior to the original breadboards. Even looks can be deceptive when one hides ugly breadboards behind more attractive front panels.

### QUASI-PRINTED BOARDS

Some experimenters prefer to build equipment that looks like a PCB, even

when the board is not etched in a circuit-specific pattern. One method, called “checker-board,” uses double sided circuit board with one side functioning as a ground foil. The other side consists of a matrix of small islands of copper. These regions are created either by etching or manually with a hack saw. Patterns of squares on 0.1-inch centers accommodate traditional ICs. Holes are drilled in the islands where components must reside. A large drill bit then removes ground foil around the hole without enlarging it. No holes are required where a ground connection is needed. Components usually reside on the ground side of the board. See Fig 1.3.

The double sided checker-board can also serve for breadboarding with surface mounted components. Parts then reside on the pattern side with holes drilled to reach ground. Small leaded components can also be surface mounted.

The checkerboard scheme, “Manhattan” variants, and even double-sided printed boards have fairly high capacitance from pads to ground. These are often poor quality capacitors with low  $Q$ , under 100 for epoxy fiberglass board material, and are subject to water absorption. A single sided format is preferred for critical sections of an LC oscillator application.

## 1.3 SOME GUIDELINES FOR THE EXPERIMENTER

With *Solid-State Design for the Radio Amateur* came considerable interaction with the rest of the amateur radio community. A frequent question we heard was “How do I get started with experimenting?” Or, “I’ve read about and have even built some kits and published projects, but I want to go further. I want to do my own design. What is the next step?”

A set of guidelines is offered in an attempt to answer some of these questions. These are not firm, well established rules, but mere impressions and personal biases that we have generated, approaches that work for us. They are offered without guarantee.

- **KISS:** This British term is short for “Keep It Simple, Stupid.” We often design equipment that is more complicated than needed. It is well worth some extra time during design to evaluate every part to see if it is really needed. The function of each part should be understood and justified. The circuit should function as intended. This does not imply that designs with the minimum number of parts are best. However, it is rarely justified to overdesign by adding extra components “because a problem might occur.” For example, designs with a profusion of ferrite beads and “stability enhancing” resistors may be suspect.

- **Avoid lore:** Lore, in this case, refers to “knowledge” that is based upon experiences that are divorced from careful thought. A classic example in amateur radio regards the thermal stability of LC oscillators. Envision the amateur experimenter who built an oscillator using a toroid. The circuit drifted when he opened the window to the winter weather. The next evening he replaced the inductor with one wound on a ceramic coil form, noticing less drift when he opened the window. He concluded that ceramic forms are better than toroids, having never considered the specific coil forms that were used, the other components in the circuit, or the fact that the weather had improved. Poorly executed experiments like this often generate erroneous conclusions. The resulting lore, although interesting, should always be questioned. It is always better to do meaningful measurements.

- **Plan your projects with block diagrams:** Start with small diagrams where each block is a global element, perhaps containing several stages. Expand these to show greater detail. Block diagrams will be discussed further below.

- **Generate modular equipment:** A high performance receiver, for example, should

consist of several sections, each designed so that it can be built, tested, modified, and redesigned as needed, with minimal change to the rest of the system. Even the simplest little rig should be built a stage at a time, turned on sequentially, tested, and modified as needed. Single board transceiver designs are popular in the QRP arena. But realize that the ones that work well are probably the result of several rebuilds, and even then, some don’t work very well; others are superb.

- **Avoid excessive miniaturization:** It takes much more time to build small things than those where the circuitry can expand without bound. Even when building small portable QRP transceivers, it’s often worthwhile to establish the design with a larger breadboard.

- **Base projects on your own goals:** Our central personal goal is learning through experimentation. Hence, we base projects on questions that need investigation rather than what we need or want for on-the-air operation. But your goals may be different. It is worthwhile to review and define them as a means of picking the best projects for you. Isolate primary goals from those that are serendipity.

- **Be wary of “Creeping Features.”** The term “*appliance*” often describes the transceivers that we purchase for on-the-air communications. Appliances, even ones that we build ourselves, are usually expected to have many features, but these *bells and whistles* can actually impede experimental progress. A single band, single mode transceiver can be as experimentally enlightening and informative as a multiple mode, general coverage transceiver.

- **Use the literature.** Peruse catalogs, data manuals, web sites, and even instruction manuals for circuit ideas. When a circuit method is not understood, it should be studied in texts appropriate to the technology. It is useful to build something with the part as a way to really understand that part.

- **While planning is necessary, don’t spend excessive time in the preliminary design phase of a project.** Rather, outline preliminary ideas and goals, do initial calculations (on a computer only if they are really complicated), gather parts, and begin building. Enjoy the freedom that allows you to change your mind in the middle of an investigation. Refined calculations can occur during and after construction and are not just “design phase” activities.

- **It’s not about craftsmanship:** A portion of the homebrewing community was schooled with the idea that “nice looking” circuit construction went along with good performance. But the two factors are generally isolated. This is illustrated in **Fig 1.4**. There is no relationship between having a nice looking, orderly circuit board and good performance from that board. Indeed, those saddled with the chore of designing a printed board to perform as well as an *ugly* breadboard may wonder if there might be an inverse relationship!

- **Use breadboarding over a ground plane for communications circuits, especially when investigating new ideas.** Use vector board or wire-wrap methods for slow digital circuits, but treat fast digital circuits as if they were RF functions. In general, build with those methods that will offer the best, low inductance, grounding while allowing circuits to be quickly designed, assembled, and tested. If you are concerned with aesthetic details, build a second version. Alternatively, an attractive panel can be used to hide ugly, but highly functional breadboards.

- **Build what you use, and use what you build:** Those of us in the homebrew end of amateur radio often kid our appliance operator friends, suggesting that a “real ham” should build instead of just operate. Some avid experimenters may take this too far; they build a rig, use it just long enough to confirm functionality, and go on to the next project, missing some exciting discoveries along the way. By using the equipment with tempered intensity, the experimenter will discover the strength and weakness of the rig, allowing the next project to be even more successful. The same arguments might be applied to software developments!

- **Beware of the golden screwdriver:** A good friend, WA7MLH, encountered a fellow on the air whose sole method for experimentation was to adjust all of his equipment for maximum output. He did this with a favorite screwdriver, which he treated as golden. After careful tweaking of all circuit elements that could be adjusted, he was almost always able to coax a 100-W transceiver into delivering 110 W of output. Unfortunately, what started as a good piece of equipment had become a distorted disaster. While we all tend to adjust circuits for “maximum smoke,” linear circuitry should be confined to operate under linear conditions. It is important that the limits be recognized and adhered to. This is especially important when building SSB gear. Alignment means adjustment to the proper, measured level,

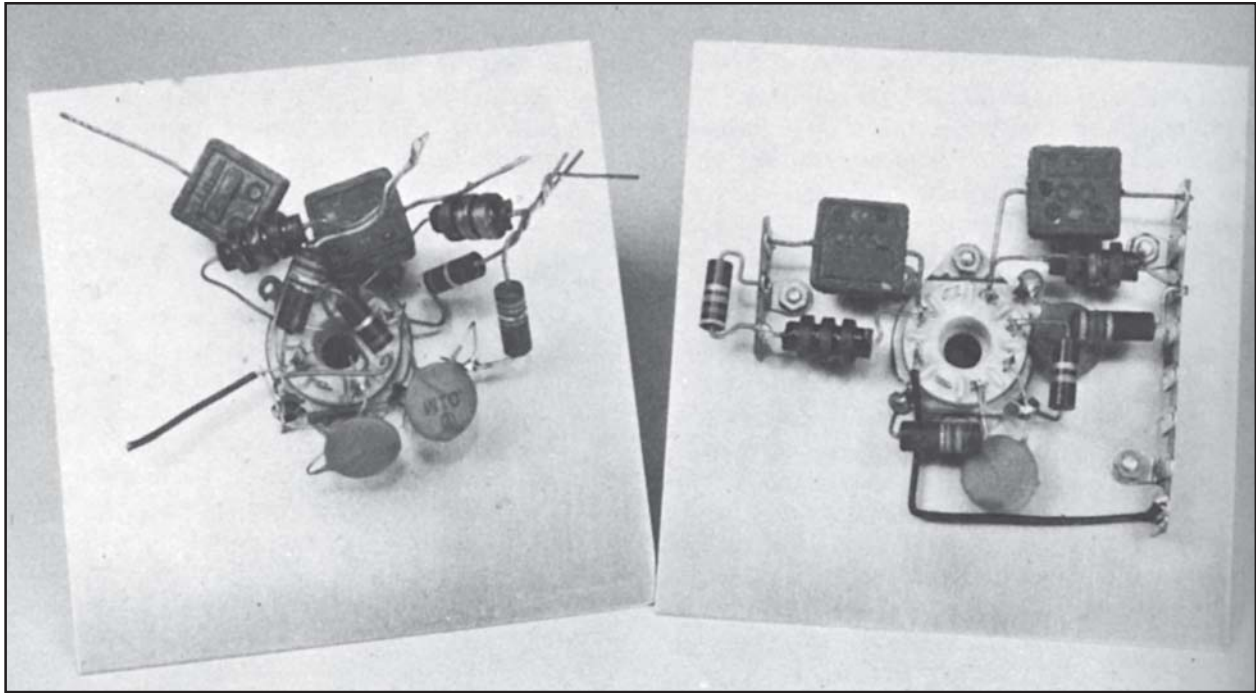

Fig 1.4—“Nice looking” circuit construction does not always equate to good circuit performance.

which may differ from maximum.

- Always keep notebooks for experiments: Record those wild circuit ideas that come up while you cut the lawn or watch TV; record important data during experiments, including the temperature when you open the window; take notes on the circuits that you build, including changes that are made during building and “turn on”. Date the notebook and place small dated labels inside the rigs so you can find the data when it’s needed. Use bound or spiral notebooks rather than loose-leaf documents, for they are more permanent. A long term computer based index of notebooks is very useful.

- Find others with the same passion for experimenting: Although this guideline is pretty obvious, it’s also easy for the experimenter to become isolated in his or her own world. Builder hams are rarely isolated. Finding the local ones will give you a place to communicate your ideas, hear about new thoughts, and to share junkbox parts as well as test equipment. Ask at

local clubs to find out who is building. Listen to the appropriate nets and attend the specialty clubs. Write to fellows who author articles of interest, especially if they live nearby. Watch the chat sessions on the Internet or the Web. Amateur radio is about communications, so don’t hesitate to communicate.

- Look toward the ordinary for explanations: When a design is not working as well as it should, we look for explanations that will explain the differences. All too often we consider the complicated answers, only to discover that the real answer is in the “obvious.” It is always worthwhile to return to fundamentals.

- Strive to build equipment that does not pollute the already abused radio spectrum: Make an effort to generate *clean* equipment, meaning that it does not emit signals at frequencies other than the intended ones. While most of this concern is with transmitters, the ideas should also be applied to receivers. The difficult question is “How clean is clean enough?” The

FCC has specifications for spurious emissions from US transmitters. These specifications depend upon transmitter output power. Even for equipment running full power, the specifications are generally easy to meet at HF. When power drops below 5-W output, they become even easier. Throughout this text we take the approach that even greater levels of cleanliness will be sought. This book includes a chapter on test equipment. One of the items featured there is a spectrum analyzer that will allow the builder to measure spectral purity.

A final “rule:” Don’t let any of these rules get in the way of experimenting and building! It’s OK if there are things that you don’t understand even if that includes the project you are about to build, for you will understand much more when you are finished. The real goal of this pursuit, and of this book is to *learn by doing*. The same can be said for other “rules” that may appear in the literature or on the web: Don’t let them keep you from experimenting.

## 1.4 BLOCK DIAGRAMS

Fig 1.5 shows a collection of elements that can be used in a detailed block diagram of a radio. This short list is generally extensive enough to describe the non-digital designs in this book.

Schematic and block diagrams serve a variety of purposes in electronics. The purpose of the block diagram is to present the functions and their interconnection used in a piece of equipment. Schematic diagrams present the details.

A block diagram is a useful way to plan and describe the equipment we wish to build. The block diagram will serve as the starting point for mathematical analysis that we may apply to the overall system. It can also emphasize the functions required to complete the design. This is illustrated with Fig 1.6 showing a direct conversion transceiver for the 40-meter band. Several filters are shown, illustrating the functions that are important for good performance. The low pass and the high pass between the mixer and audio amplifier are simple, consisting of one component each. There may be no components for the signal splitter, but the function remains.

Fig 1.7 shows a more elaborate circuit, a super-heterodyne SSB/CW transceiver for the 50-MHz band. The phasing method can also be used; such a 50-MHz transceiver is presented in Fig 1.8. Designing any of these systems begins by forming the block diagrams, which includes specifying each of the blocks. Once this is done, the individual circuits can be designed. Some elements are missing in the block diagram in the interests of clarity. It will be useful to add block detail during circuit design.

Some block details may differ from the final implementation, but functions remain. For example, the splitter and phase shifting functions are often combined in quadrature combiner circuits operating at RF. We sometimes show a 90-degree phase shift in one path with none in another where actual circuitry merely maintains a 90-degree difference.

These figures offer a glimpse of what the text will cover. The design of the block elements will each be discussed in individual chapters. Then, the blocks will be assembled in *system* chapters related to filter, phasing, and digital signal processing systems.

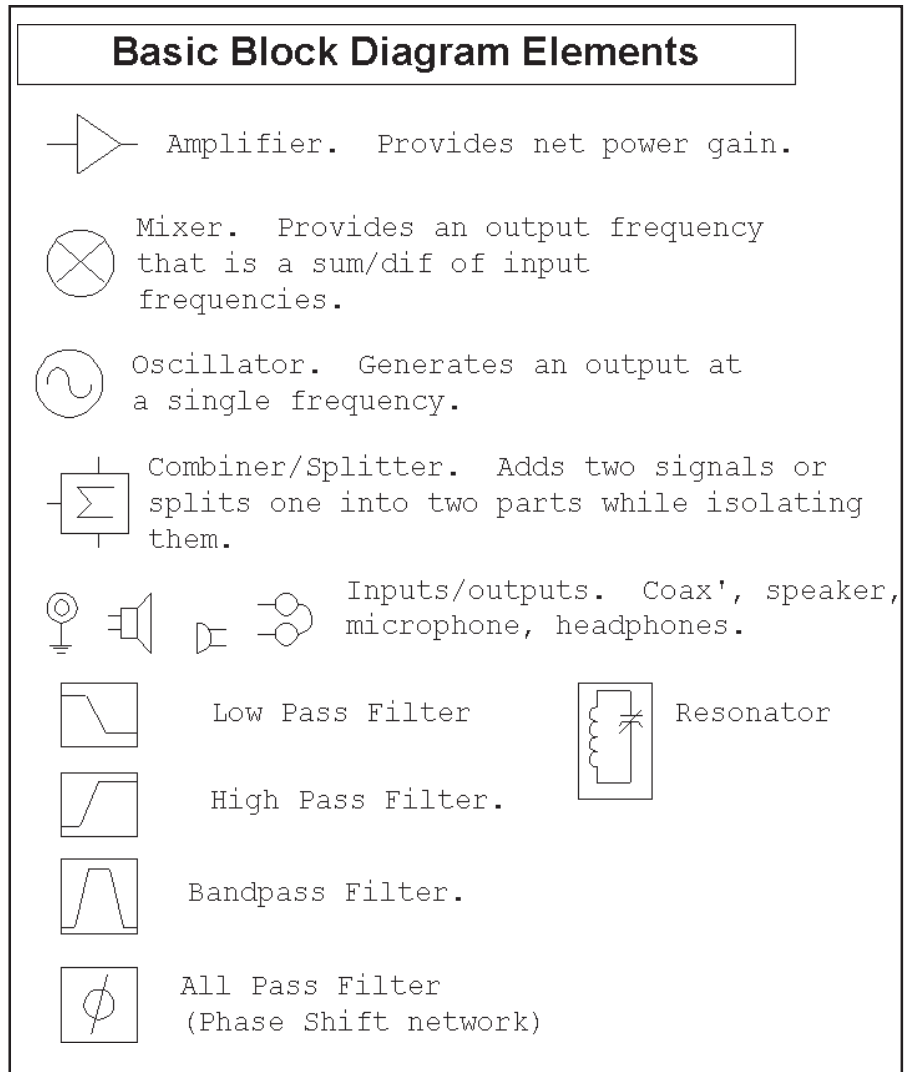

Fig 1.5—Common block diagram elements.

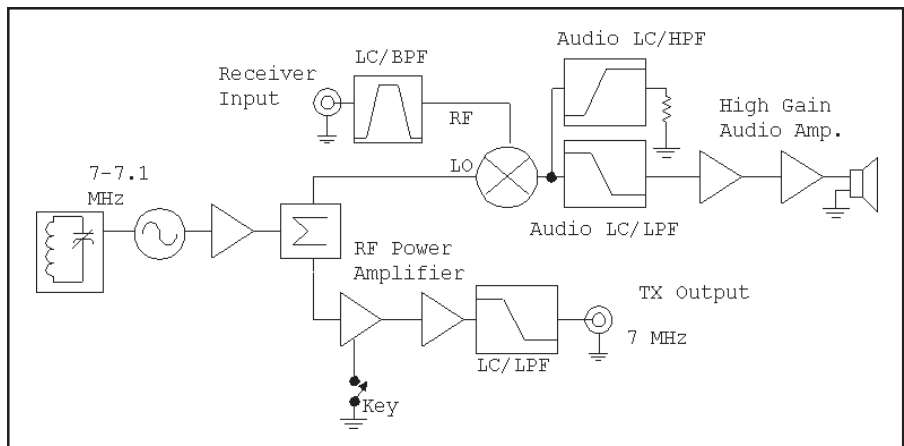

Fig 1.6—Block diagram of a direct conversion transceiver.

## 1.5 AN IC BASED DIRECT CONVERSION RECEIVER

This receiver design is one of the simplest possible that will allow CW and SSB signals to be received. It offers performance enough for on-the-air contacts while serving as an introductory construc-

tion effort.

The basis for this receiver is the NE602 (or NE612) integrated circuit. Originally introduced by Signetics in the late 1980s, the chip is easy to use and offers good per-

formance among very low current receiver components. The NE602 contains a mixer and an oscillator, two essential blocks needed for a receiver. The mixer in a direct conversion receiver serves to heterodyne the incoming antenna signal directly down to audio. The oscillator provides mixer LO (local oscillator) injection for this conversion. The oscillator within the NE602 is a single transistor followed by a buffer amplifier of undisclosed complexity. The NE602 mixer is a doubly balanced circuit of a type known as the Gilbert Cell with operation outlined in a later chapter.

The LM386N audio amplifier following the NE602 completes the receiver. The LM386N will drive a small speaker, or headphones of high or low impedance. The ideal set of “cans” to use with this receiver is a light weight pair of the sort used with jogging receivers or similar consumer gear.

The receiver is shown schematically in Fig 1.9. Our version is built using the “ugly” methods outlined earlier. If you use a pre-etched and drilled circuit board, take the time to study the board layout in detail, and trace the circuit while studying the schematic diagram. Merely stuffing parts and soldering will provide you with no more than soldering practice.

The signal from the antenna connector is applied to a pot that serves as a gain control with output routed to a single tuned circuit using L1, a toroid inductor. This circuit drives the mixer input at NE602 pins 1 and 2. The load within the IC looks like a pair of 1.5-kΩ resistors from the input pins to a virtual ground.

The NE602 oscillator has a collector tied to the positive power supply. The base of that transistor is available at pin 6 while pin 7 goes to the emitter. Internal bias resistors set the voltage and establish a current of about 0.3 mA in the Colpitts oscillator. Feedback capacitors in our circuit run between pins 6 and 7 and from pin 7 to ground. A 270-pF capacitor then ties the base to the rest of the tuned circuit.

A simplified version of the oscillator circuit is shown in Fig 1.10. This illustrates the way a simplified circuit is used to calculate the resonant frequency. Fig 1.10A shows the complete oscillator. But, the two 680-pF feedback capacitors have a series equivalent of 340 pF, as shown in part B of the figure. In going from Fig 1.10B to Fig 1.10C, we resolve the 50-pF variable and 10-pF fixed into 8.3 pF; the 270 and 340 pF become 150 pF. We evaluated both variable capacitors at their maximum value. Fig 1.10C has nothing but parallel capacitors which add directly to

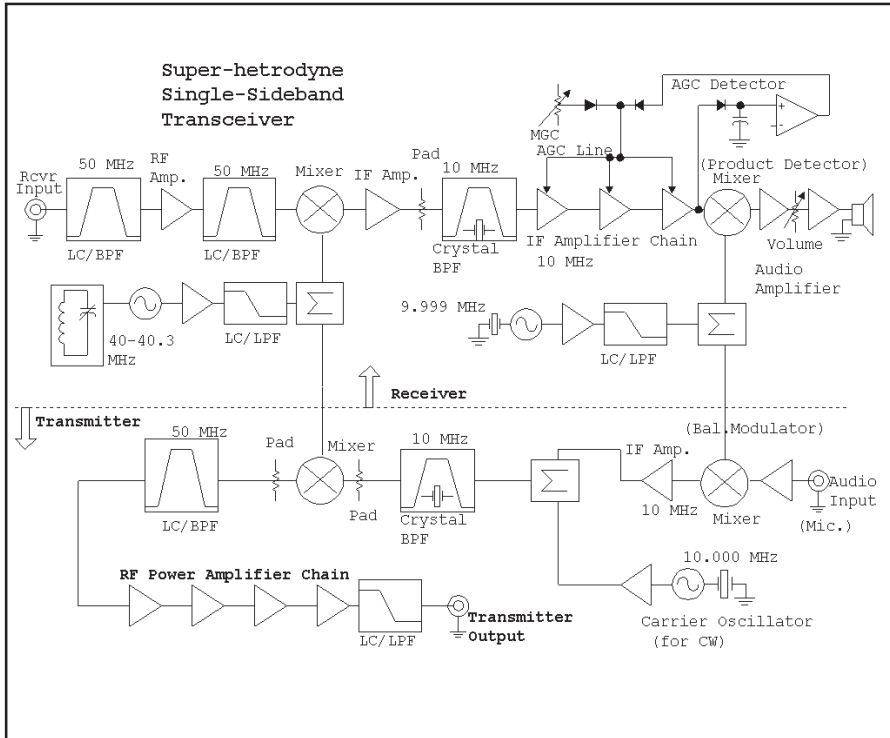

Fig 1.7—Block diagram of a super-heterodyne SSB transceiver.

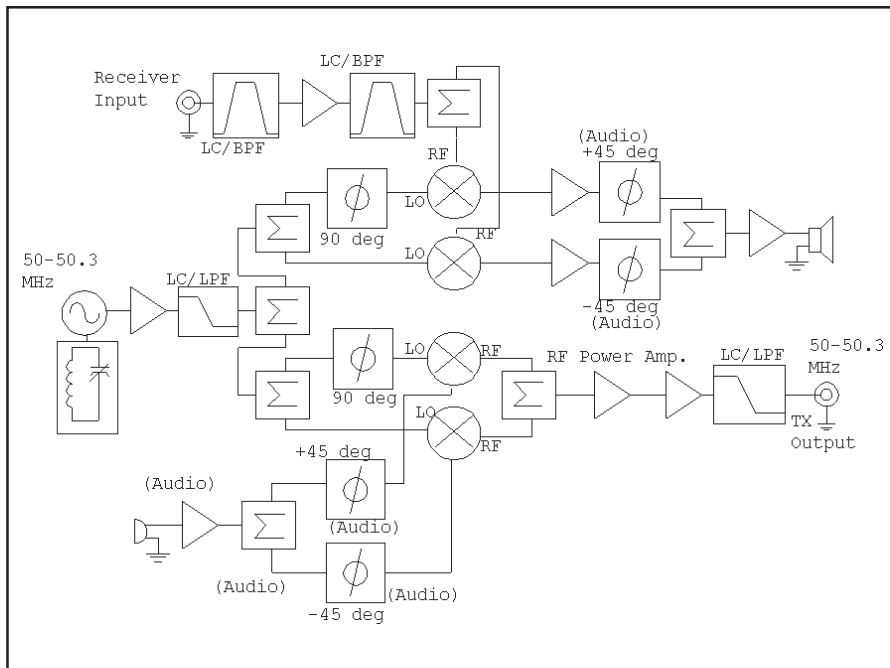

Fig 1.8—Block diagram of a phasing method SSB transceiver.

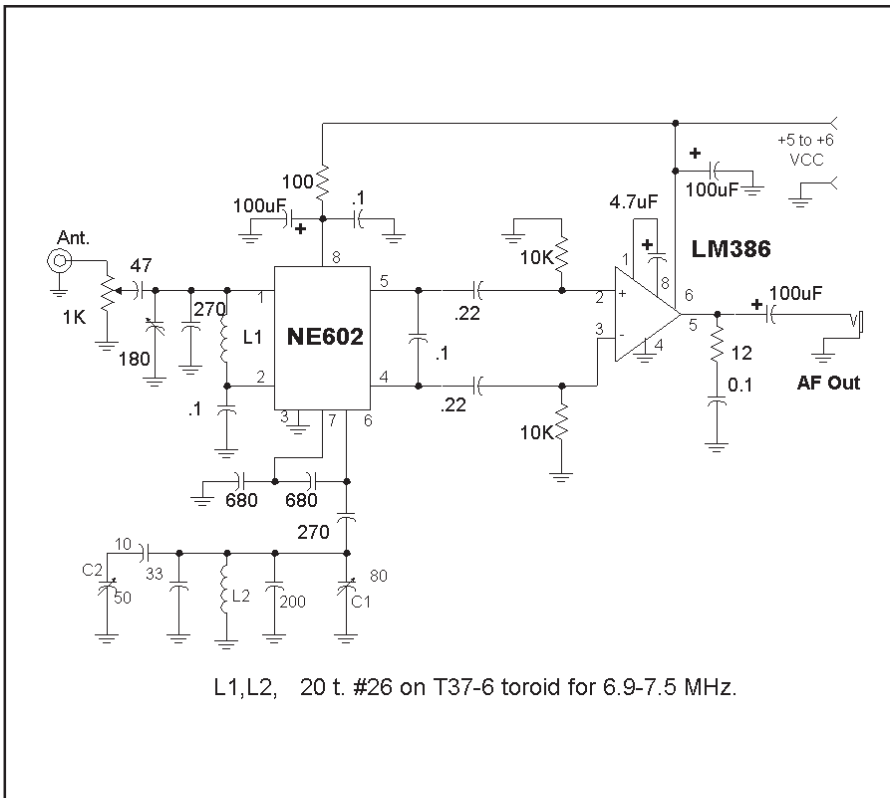

Fig 1.9—Direct conversion 7-MHz receiver using two integrated circuits.

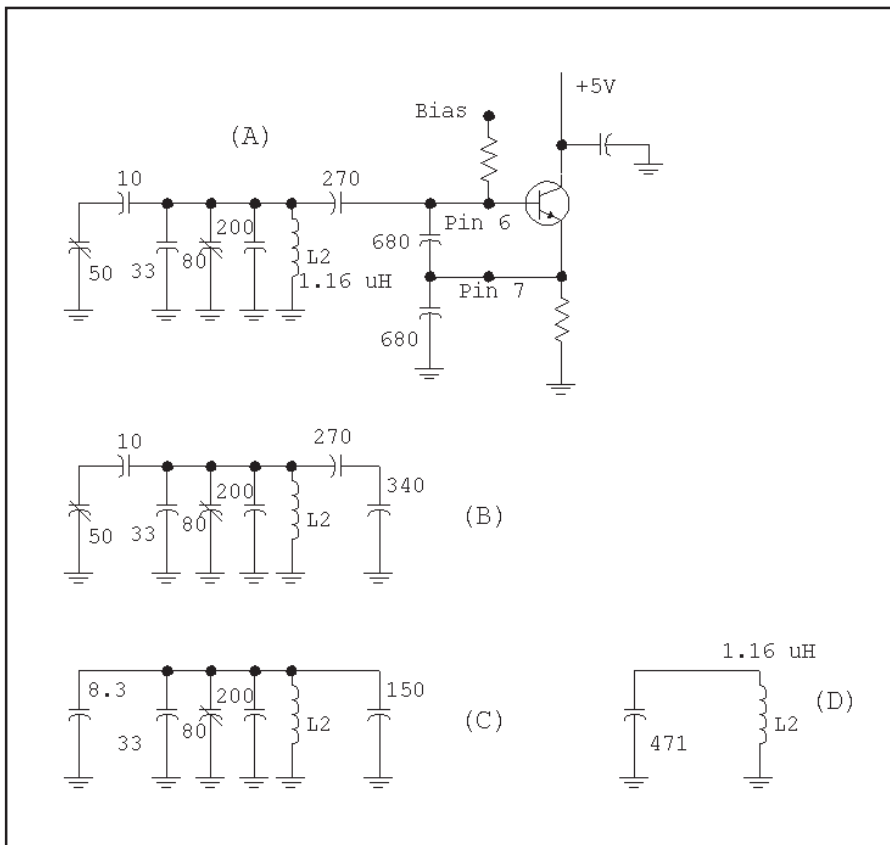

Fig 1.10—Simplified version of the oscillator in a NE602. See text for explanation.

form Fig 1.10D. A simple resonance calculation shows tuning to 6.9 MHz.

Two variable capacitors (C1 and C2) are used in our oscillator. They are nearly the same value. The larger, C1, directly parallels the inductor. A detailed analysis shows that it will tune over a wide range, the full 6.9 to 7.5-MHz span. C2 is “padded down” with a 10-pF series capacitor. C2 has a value ranging from 5 to 50 pF. The series capacitor then generates a composite C ranging from 3.3 to 8.3 pF, a 5-pF difference. Add capacitance in parallel with C2 to create even greater bandwidth (resolution or low tuning rate).

All fixed capacitors should ideally be NPO ceramic types, readily available from major mail order sources. But, don’t hesitate to try other caps if you have them in your junk box. The worst that will happen is that the receiver will drift more than desired. New parts are easily substituted later.

These capacitor variations are doubly significant. First, you can adapt a tuned circuit to work with whatever you have on hand. For example, common 365-pF AM broadcast capacitors can be used in both positions with appropriate padding. Second, the use of two capacitors is a very practical means for building simple receivers while avoiding the mechanical complexity of a dial mechanism. We have used double cap tuning for transceivers in other parts of the book. Adapt the circuit to what you have available.

The mixer input network at L1 that injects antenna signals into the NE602 uses an inductor identical to that in the oscillator, tuned with a mica compression trimmer capacitor. Any variable can be used here. If a 365-pF panel mounted cap is used, the 270-pF capacitor could be reduced in value. If the only available variable capacitor is much smaller than 180 pF, you may have to resize L1, or add or subtract net capacitance a bit to hit resonance. The inductance can be reduced by spreading or removing turns, or increased by compressing turns. Both circuits are very tolerant of such changes.

Once the mixer has been wired, most of the receiver is finished. The LM386 is a low power part with no heat sink required. This receiver draws only 7 mA when signals are low, with more current with louder signals. A simple 5-V power supply works well. A 6-V battery pack will run the receiver for extended periods.

The NE602 mixer features excellent *LO to RF isolation*. This means that there is little LO energy appearing at the mixer RF port, and hence, the receiver antenna terminal. The presence of such energy can lead to a common problem of “tunable hum” with



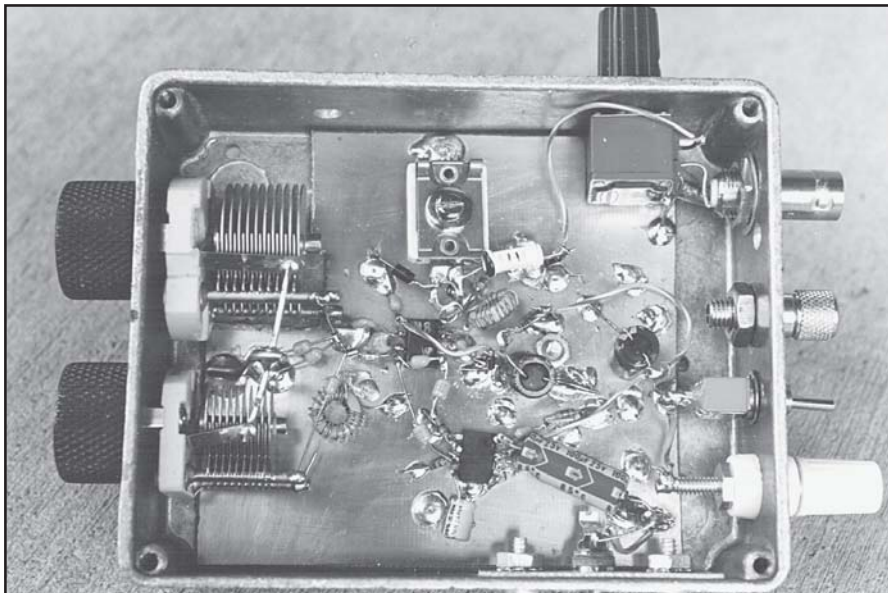

Fig 1.11—Direct conversion receiver assembly.

some direct conversion receivers.

The receiver also has problems. Some, the audio images, are intrinsic to all simple direct conversion receivers. This is the price, but also the thrill of such a design. The selectivity is lacking. This can be remedied with audio filters that can be placed in the receiver. Examples of audio filters are found elsewhere in this book. These filters would go between the mixer and the audio amplifier. It is easy to add such things to a breadboarded receiver, but more difficult with a printed board.

The greatest performance deficiency is

the poor strong signal handling capability of the receiver. Although helped a bit by placing the only gain control in the antenna lead, the problem is intrinsic to the NE602 mixer. The basic Gilbert Cell is capable of much more, but only when biased to draw considerably more current. The current is kept low in the NE602 by design, for it is intended for battery powered consumer equipment and not ham gear. Strong, high performance direct conversion receivers are described later in the book.

Initial turn-on and adjustment is straight forward. Apply power initially with a

100- $\Omega$  resistor in the power supply line. The resistor serves as a fuse if you have done something drastically wrong. Inserting the headphones when the output capacitor is uncharged will produce an audible pop. If the audio seems to be working, turn the receiver off, remove the extra resistor, and start again. Attach an antenna, advance the gain control and tune C1. Signals should be heard. Adjust the front-end tuned circuit for maximum signal. If you have a calibrated signal generator you can inject a signal and see if the operation is at the right frequency. If you have a general coverage receiver available, you can attach the antenna of this receiver to that of the general coverage receiver where you will be able to hear the LO signal. If an antenna is not available, you can throw 20 or 30 feet of wire out on the floor. While this is not going to compete with a good outdoor antenna, it will provide signals in abundance to listen to and confirm receiver operation.

The receiver in Fig 1.11 was built for the 40-meter band. If you want to try a different band, all that is required is to change the two inductors. Increasing the 1.16- $\mu$ H inductor to 4.5  $\mu$ H will drop the receiver right into the 80 meter band. A band switching version would be practical.

The first popular receivers of this sort appeared in the USA in a *QST* paper by WA3RNC.<sup>4</sup> Variations of a similar sort were generated and published in Europe by George Dobbs, G3RJV. George used a double tuned circuit in the front end to improve signal handling properties.

## 1.6 A REGENERATIVE RECEIVER

There was a time when simple vacuum tube regenerative circuits were the only receivers available to the radio amateur. Even when super-heterodynes became possible, the regenerative design remained as the entry level radio.

Regenerative receivers have become popular again, but they now generally use semiconductors. Much of this popularity has been fueled by the work of Charles Kitchin, N1TEV.<sup>5,6</sup> People now build regenerative receivers for the sheer joy of listening to a receiver that is extremely simple, yet is capable of receiving signals from all over the world. The radio offered here tunes from 5.5 to 16 MHz, covering three amateur bands, 7, 10.1, and 14 MHz, as well as international short-wave broadcasts at 6, 7, 9.5, 12, 13.5, and 15 MHz.

The core of a regenerative receiver is the detector. Fig 1.12 shows a JFET version of a classic regenerative detector using a “tickler coil.” Signals from the antenna or a preceding radio frequency amplifier are applied to the tuned circuit, producing a voltage at the FET gate. This produces FET drain currents that vary at the RF rate. The RF drain current flows in the tickler coil which couples energy back to the original coil through inductive transformer action. If enough energy is coupled back, the circuit oscillates. Even when the coupling is weaker, insufficient for oscillation, the circuit can have very high gain. This makes the weakest signal large within the detector circuit. The presence of any large signal in a “square-law” device like a JFET will produce detection, which

means that audio also appears within the circuit. It need only be coupled out and applied to headphones or an audio amplifier to complete the receiver.

Our receiver uses some slightly unusual circuits that simplify the design. The detector is based upon a little appreciated variation of a traditional Hartley oscillator, a variant *without* transformer action. Instead, two series inductors, L1 and L2, serve as the traditional “tank,” or resonator. Toroids were used, although Q is not critical and traditional cylindrical coils will also work. Indeed, low Q radio frequency chokes offer opportunity to the experimenter.

The detector, Q2, uses a junction field effect transistor. While we used a 2N5454, the detector worked well with any N-chan-

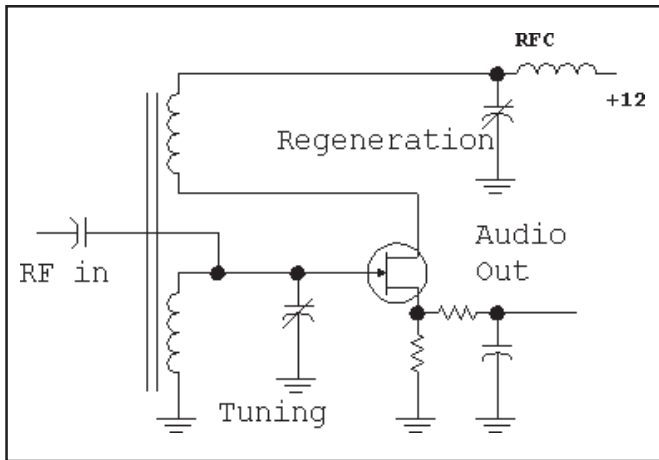

**Fig 1.12—A classic regenerative detector.**

C3, each with a large knob. C2 is a “band-set” while C3 is a higher resolution “band-spread” tuning, an action resulting from the series and parallel fixed capacitors around C3. Regeneration is controlled with another 365-pF variable capacitor. None of the variable capacitor values are terribly critical. If you find others at a flea market or hamfest, you can adapt the circuit to use them. That’s part of the charm of a personalized regenerative receiver; it applies positive feedback to your imagination.

This circuit uses an RF amplifier, Q1. The gain is not really needed, or even desired. However, the amplifier provides a relatively stable driving impedance for the detector, and is a convenient way of varying the strength of the signals arriving at the detector. The RF amplifier is preceded by a 5th order low pass and 3rd order high pass filters. The high pass rejects signals from the AM broadcast band that could overload the receiver. The low pass attenuates FM and TV broadcast signals that could inter-modulate in the RF amplifier or detector, producing distortion within the receiver tuning range.

Audio gain is provided by Q3 driving

nel depletion mode FET we could find in our junk box. This included the U309, J310, 2N4416, 2N3819, and MPF-102, as well as some even more obscure parts. We couldn’t find an FET that would not work. Use what you have! The complete receiver schematic is shown in **Fig 1.13**, and a front panel photograph appears in **Fig 1.14**.

We wound our own 1-mH choke for L3

using a large ferrite bead. A 1-mH or 2.5 mH RFC will work well in this position. A 1-K resistor even functioned in place of L3, although the regeneration control was not as smooth as it was with an inductor.

The mechanical complications of a dial mechanism are avoided by tuning the receiver with two variable capacitors, C2 and

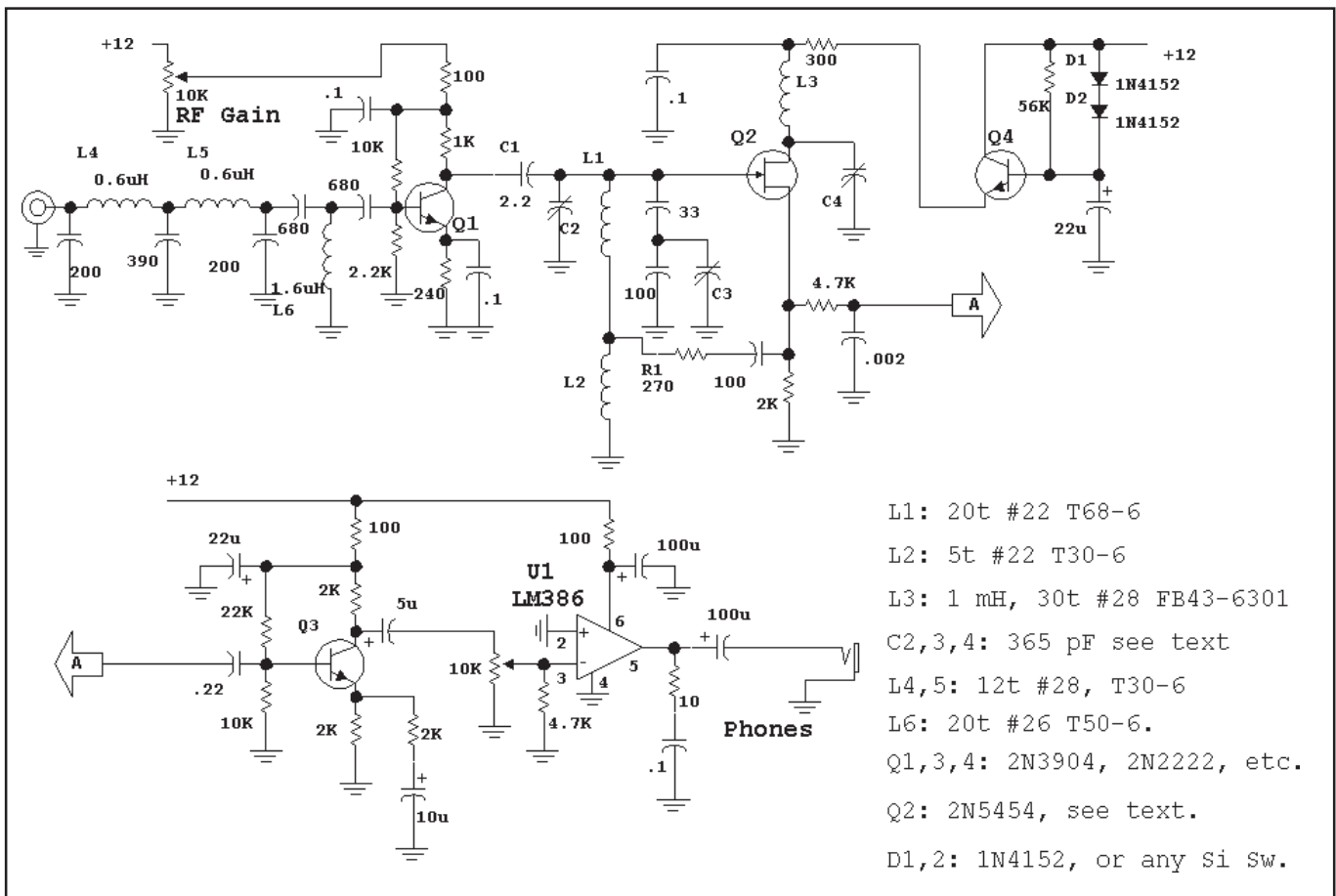

- L1: 20t #22 T68-6
- L2: 5t #22 T30-6
- L3: 1 mH, 30t #28 FB43-6301
- C2,3,4: 365 pF see text
- L4,5: 12t #28, T30-6
- L6: 20t #26 T50-6.
- Q1,3,4: 2N3904, 2N2222, etc.
- Q2: 2N5454, see text.
- D1,2: 1N4152, or any si Sw.

**Fig 1.13—A regenerative receiver tuning from 5.5 to 16 MHz. See text for discussion of parts and construction.**

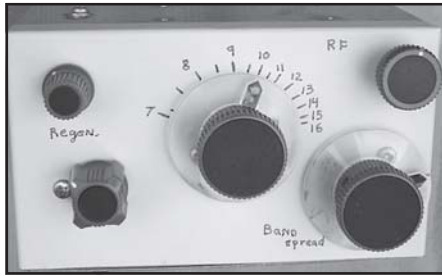

Fig 1.14—Front panel view of the regenerative receiver.

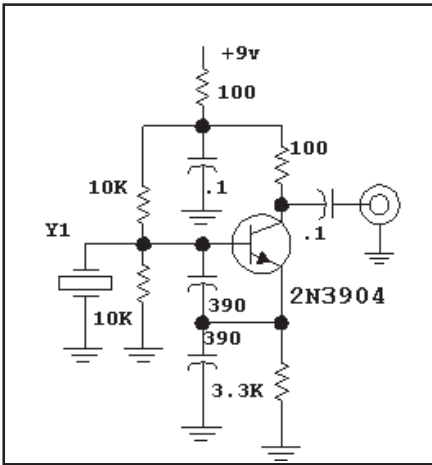

Fig 1.15—A simple crystal oscillator becomes a substitute for a signal generator.

U1, a common LM386N output amplifier. This will drive either low impedance “Walkman” type phones or a small speaker. Walkman is a Sony trademark. Q4 is an active decoupling filter that provides hum-free dc to the detector. Although the receiver of Fig 1.13 is shown with a 12-V power supply, it worked well with voltages as low as 6. Typical current is 20 mA at 12 V.

A signal generator with frequency counter is useful during initial experiments with the receiver. However, many builders may not have them available. Fig 1.15 shows a suitable substitute, a crystal oscillator that will operate anywhere within the receiver range. Numerous inexpensive crystals are available from the popular mail order sources that will provide a starting point. For example, a 10-MHz crystal available for under \$1 will mark the 10.1-MHz amateur and the 9.5 to 10-MHz SW broadcast bands.

The receiver can be built in any of many forms. A metal front panel is a must, affording shielding between circuitry and

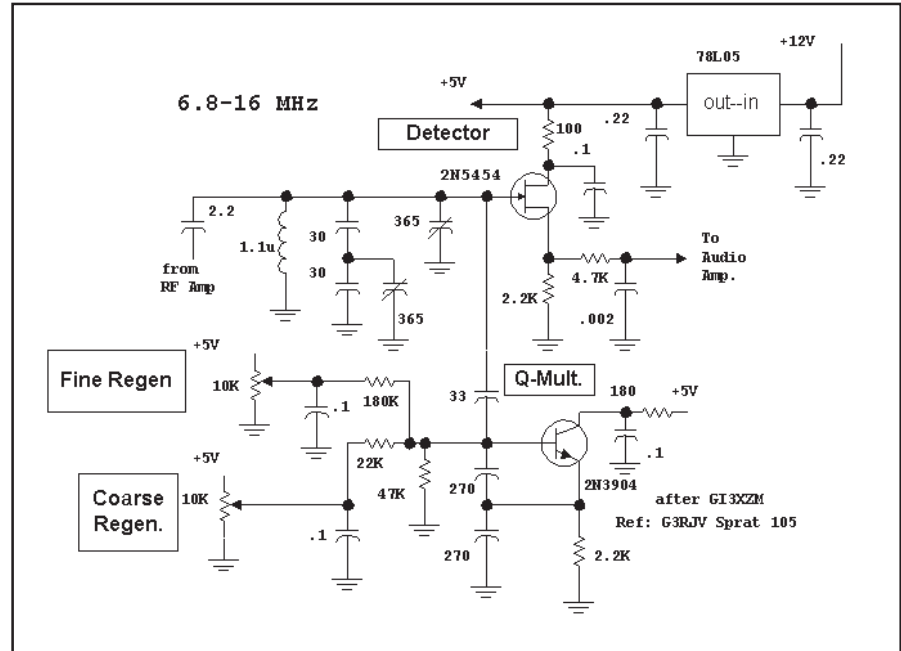

Fig 1.16—Alternative regenerative detector.

the operator’s hands. However, the rest of the receiver could be as simple as a block of wood found in the garage. Our receiver was built “ugly” with scraps of circuit board material. One scrap will suffice, although our receiver used three, an indicator of earlier experiments. Other breadboards will work as well, but a printed circuit board should *never* be used for a regenerative receiver. Even if dozens are to be built, such as in a club effort, the project should emphasize open ended, flexible breadboarding to encourage experimentation.

Some experimentation may be required to set up the regeneration. Increasing L2 by a turn or decreasing R1 will both increase regeneration. However, too much inductance at L2 or too little resistance at R1 will produce such robust feedback that regeneration cannot be stopped or easily controlled.

Operation of this, or any regenerative receiver is a multiple control effort. Begin with the regeneration control, C4, at minimum capacitance, unmeshed, and set the two tuning controls at half. Set the RF gain for maximum gain, +12 V on the amplifier, with the audio gain in the middle and attach an antenna. Tuning C2 may produce a signal. Now slowly advance the regeneration, adding C at C4. It is normal for background noise to increase with a mild “plop” occurring in the headphones as the detector begins to oscillate. If the detector

becomes overloaded, reduce the RF gain control. Tune the receiver until an AM signal is found. Then reduce regeneration until the “squeals” subside. CW and SSB are best received with the regeneration well advanced. While the receiver works best with an outside antenna, it will function with as little as a few feet of wire tacked to the wall. The signal generator of Fig 1.15 requires no more than a two foot piece of wire on its output, somewhere in the same room as the receiver.

There are numerous interactions between controls, features that offer challenge and intrigue for the experimenter who takes the time to enjoy them. Numerous circuit refinements are available to the experimenter who wishes to continue the quest. The experimenter will discover a great deal from his or her efforts in operating this receiver. The availability of very high gain through positive feedback can be used to great advantage. But operation can be a greater challenge than found with a more advanced receiver.

A more recent experiment used a different regenerative detector, shown in Fig 1.16. This circuit eliminates one of the variable capacitors used in the other circuit, replacing it with a pair of potentiometers. This circuit was featured in a recent issue of *SPRAT* by George Dobbs, G3RJV, although the circuit seems to be the brainchild of G13XZM.<sup>7</sup> Performance of the two circuits is similar.

## 1.7 AN AUDIO AMPLIFIER WITH DISCRETE TRANSISTORS

The amateur literature is rich with older designs using high impedance headphones. These designs are often very battery efficient, a vital performance virtue for portable or emergency equipment. But high impedance headphones that can be used with the more efficient designs have become rare. The answer to this dilemma is a simple audio amplifier that will drive low impedance headphones while maintaining reasonable efficiency.

One solution to the problem is one of many integrated circuits. Throughout the book we used the LM386 or op-amps to drive headphones of the Sony “Walkman” variety. An alternative circuit is shown in Fig 1.17. This amplifier uses commonly available discrete transistors. The version of the circuit that we built used leaded parts, but could just as well be built with SMT components. Q1 functions as a gain stage. The 2.2-k $\Omega$  collector load (R8) with 100- $\Omega$  degeneration (R4) produce Q1 bias current of 2 mA for an approximate voltage gain of 20. Q2 functions as a floating voltage source that establishes bias for complementary emitter-follower output transistors Q3 and Q4. Negative feedback through R3 reduces gain and establishes overall bias. This cir-

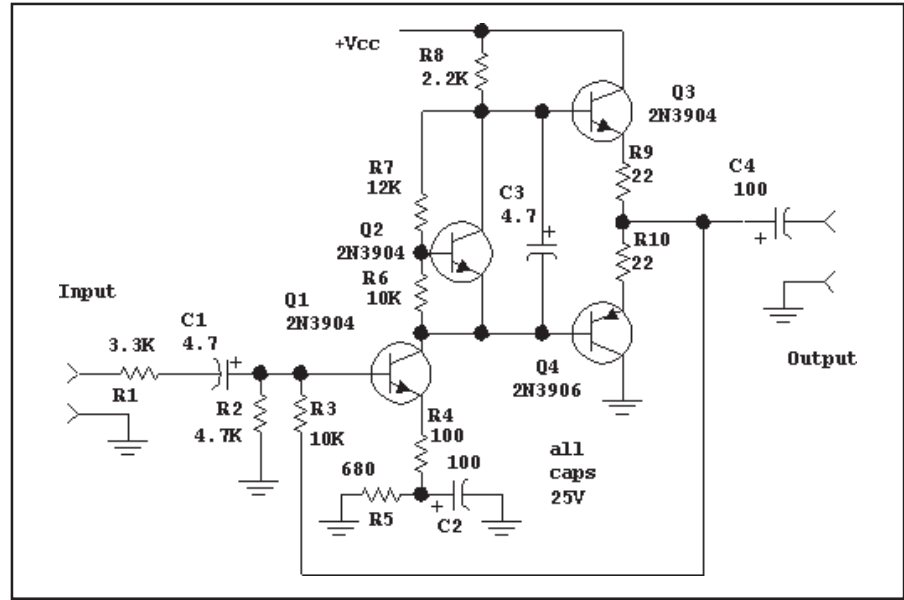

Fig 1.17—Simple audio amplifier using discrete components.

cuit is similar to many of the simpler integrated circuits. This circuit functions well with power supplies from 5 to 15 V.

An IC is usually the preferred solution.

However, the discrete solution is available when an IC is not. All of the transistors in this circuit are very inexpensive and usually found in the experimenter’s junk-box.

# 1.8 A DIRECT CONVERSION RECEIVER USING A DISCRETE COMPONENT PRODUCT DETECTOR

The direct conversion receiver described earlier used an NE-602 integrated circuit to fulfill both the detection and the local oscillator functions. Discrete (non-integrated) components can also be used in these applications. The receiver shown in **Fig 1.18** uses a differential amplifier as the product detector. This design, shown for operation in the 40-meter band, has been built with both traditional leaded components and with surface mounted technology (SMT) parts and appears in **Fig 1.19**.

Q1 functions as a local oscillator. Voltage control is used with any of several common tuning diodes. The Colpitts circuit uses small powder iron toroids for both leaded and SMT components. C1 is a combination of NP0 capacitors, selected during construction to resonate at the desired frequencies. With the parts shown, the receiver tunes over about a 50-kHz range in the 40-meter band. The range may be expanded by paralleling additional varactor diodes, increasing the value of the 82-pF blocking capacitor, decreasing the value of the 2.2-kΩ resistor in series with the tuning control, or combinations of these measures.

The oscillator is buffered with Q2, a common-emitter amplifier with emitter de-

generation. This circuit, using negative feedback, uses a form found throughout the book, one where an added component reduces gain to improve performance. The output drives the mixing product detector consisting of Q3 and Q4. An RF signal is extracted from the antenna through a gain control, low pass filtered, and applied to the base of Q5 where it is amplified and converted to a current source

feeding Q3 and Q4. The mixer collectors are bypassed for RF.

The detector output feeds a differential signal to a LM386 audio amplifier. De-coupling became important with this stage, owing to the internal resistance found with a normal 9V battery. An uncomfortable “howling” oscillation disappeared with high decoupling capacitance for the audio amplifier.

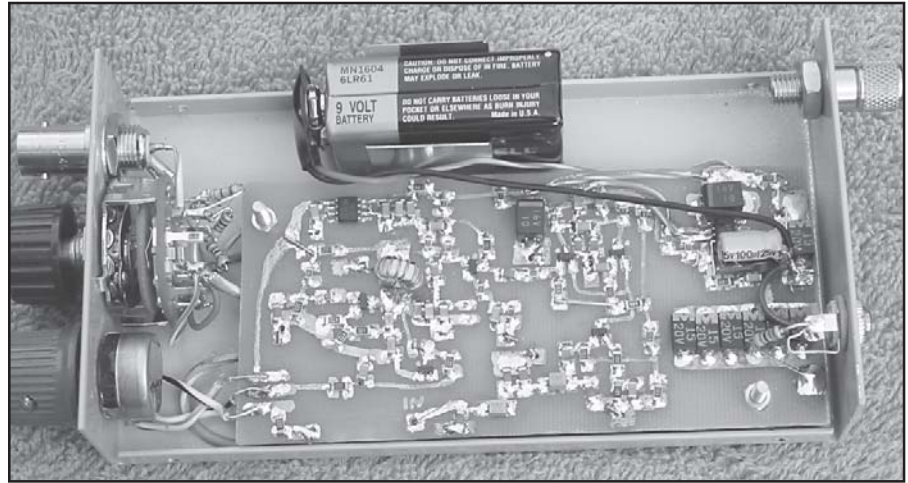

Fig 1.19—Inside view of SMT direct conversion receiver.

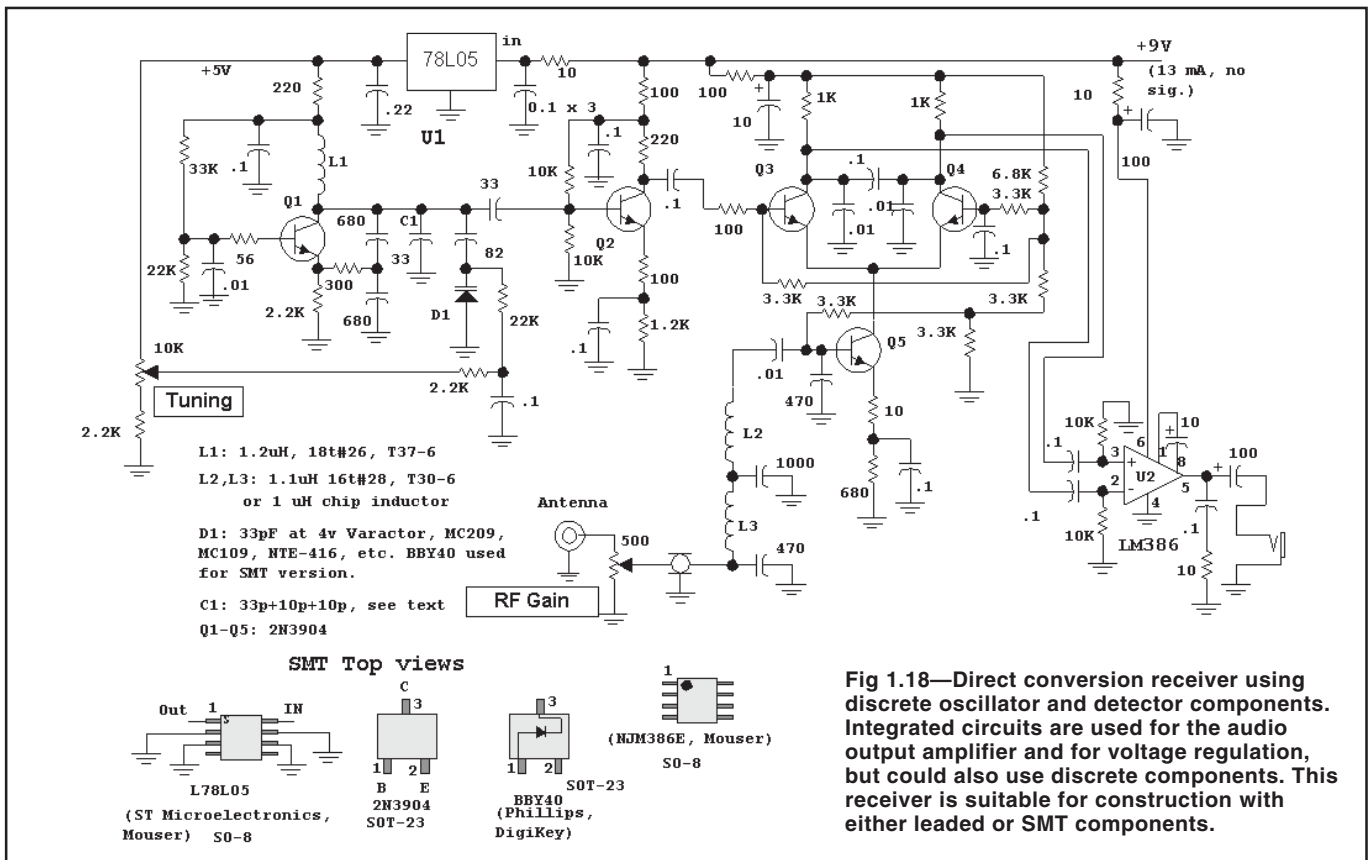

Fig 1.18—Direct conversion receiver using discrete oscillator and detector components. Integrated circuits are used for the audio output amplifier and for voltage regulation, but could also use discrete components. This receiver is suitable for construction with either leaded or SMT components.

## 1.9 POWER SUPPLIES

Among the many tools needed by the circuit experimenter, beginning or seasoned, is a power supply. Indeed, several are always useful. Batteries serve well for simple, low current applications. However, the more useful power supply extracts energy from the power mains. That ac voltage is applied to a transformer, is rectified, filtered with a large capacitor, and regulated with transistors and/or integrated circuits.

Two major design questions are presented to the beginner: What transformer should be selected and how large should the filter capacitor be? Fig 1.20 shows an example 12-V, 0.5-A design we use to address these questions.

Transformers are rated for RMS output voltage with a load. The peak voltage will be higher by a factor of 1.414, so a 12.6-V transformer will have a peak output of 17.8 V. The transformer current rating should equal or exceed the maximum desired dc current, so a 0.5-A transformer is adequate for this application. This is shown in part A of Fig 1.20. A switch and protective slow-blow fuse is added to the transformer primary.

A bridge rectifier using four diodes is added to the circuit to generate a dc output. The bridge is preferred over circuits with just two diodes, for a center tapped transformer is then not required. Bridge rectifier diodes should have an average current rating above the maximum power supply current. 1-A diodes would be fine for this application.

Some waveforms are shown in Fig 1.21. The “before filtering” voltage is the result of rectification for the circuit of Fig 1.20A. The “V-cap” trace shows the voltage across the capacitor when it is added to the circuit, Fig 1.20B. The significant detail is the *ripple*, or variation in unregulated output voltage occurring at the filter capacitor. Fig 1.22 shows ripple for two different capacitor values when the load current is 0.5 A.

A suitable regulator is the popular 7812. This three terminal regulator IC will provide the desired output with a *dropout* of about 2.5 V. Dropout is the minimum voltage difference between the regulated output and the higher unregulated input. With a 2.5-V dropout, the unregulated input must be 14.5 V or more over the entire cycle. Fig 1.22 shows that a 2000- $\mu$ F capacitor will be adequate, but 500  $\mu$ F will not. If we define  $\Delta V$  as the difference between the peak rectified voltage and the minimum unregulated value,  $17 - 14.5 = 2.5$ ,  $I$  as the output current, and  $\Delta t$  as the time for a half cycle (.0083 second for 60 Hz), the minimum capacitor value in

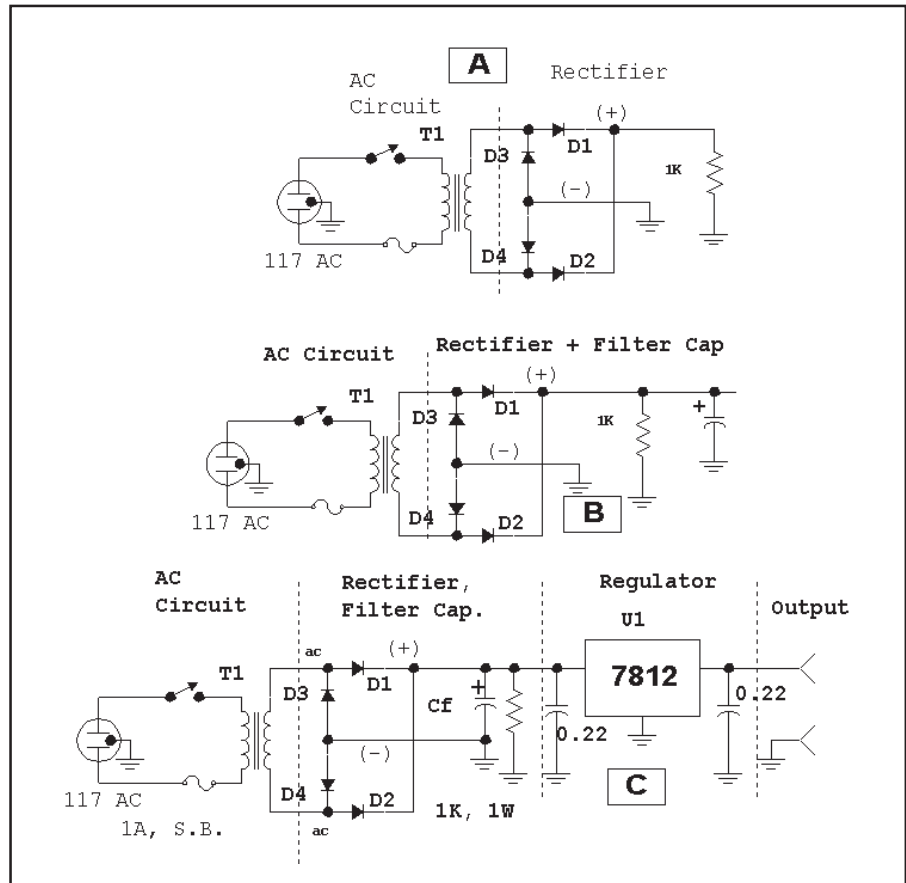

Fig 1.20—Fundamental power supply. Part A shows the transformer and rectifier, B adds the critical output filter capacitor, while C uses a 12-V regulator IC.

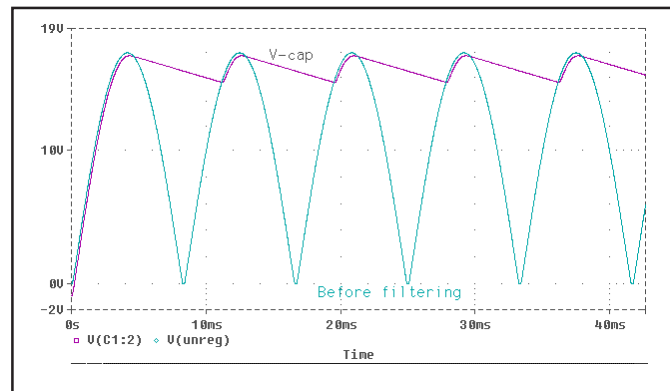

Fig 1.21— Waveforms for a simple power supply. The “before filtering” shows the raw rectified signal without any filter capacitor. The “V-cap” shows the voltage across the filter capacitor attached to the rectifier when loaded to a modest current.

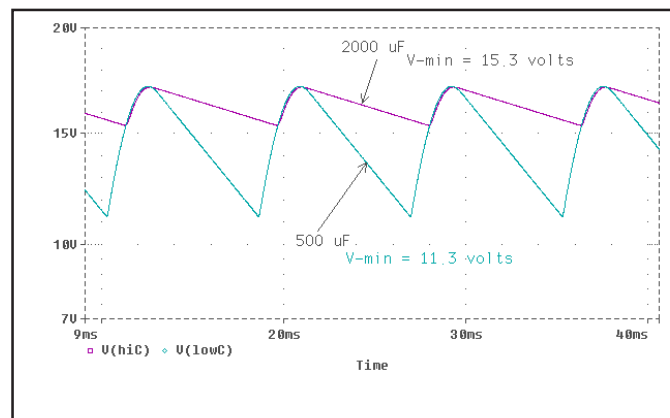

Fig 1.22—Waveforms showing the voltage across filter capacitors of two values when loaded with 0.5 A. See text discussion.

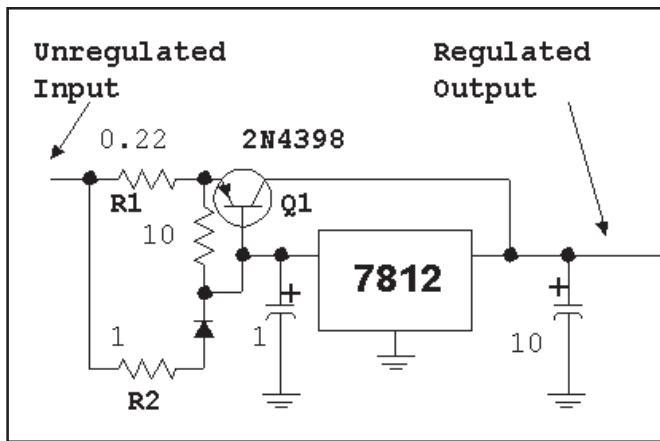

Fig 1.23—Extending the output current capability of a regulator with a “wrap-around” PNP transistor.

Farads is given by

$$C = \frac{I \cdot \Delta t}{\Delta V} \quad (\text{Eq 1.1})$$

For this example, Eq 1.1 predicts a minimum C of 1700 μF. A practical value of 2500 μF would be a good choice.

The complete circuit with the regulator is shown in Fig 1.20C. Extra capacitors, placed close to the regulator IC, serve to stabilize the IC. The user should check data sheets for the IC that he or she uses to evaluate stability. The 1-kΩ bleeder resistor consumes little current, but guarantees that the supply turns off soon after the switch is opened.

The 0.5-A rating of the 7812 becomes a problem when more current is needed. Fig 1.23 shows a circuit that will extend the output current rating by adding a power transistor. Q1 now carries most of the current with the split being determined by the ratio of R2/R1. The dropout for the total circuit is now that of the IC plus a little more than a volt for the diode/transistor and R1 and R2.

Fig 1.24 shows a supply using an LM317. This is a programmable voltage part that can supply outputs from 1.2 up to 37 V, set with two resistors, for an output current of 1.5 A. The power supply we built, used extensively for developing many of the circuits in this book, was variable voltage and also included a 12-V regulator as a second output. An 18-V transformer was used, for we wanted regulated outputs up to 20 V.

Many other regulators are found in vendor catalogs, many with considerably higher output currents and lower dropouts. The experimenter is encouraged to build his own circuits using them. Switching mode regulators offer interesting performance virtues with equally interesting challenges.

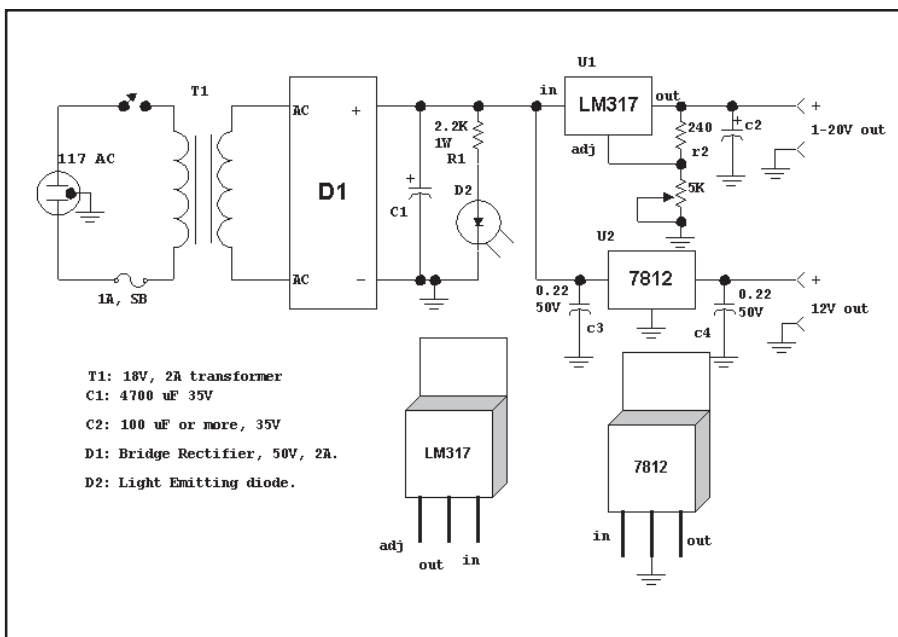

Fig 1.24—Practical dual output power supply featuring the LM-317 regulator.

## 1.10 RF POWER MEASUREMENTS

Before one can do any meaningful experiments with transmitters, you must be able to measure RF power. A basic scheme for doing this is shown in Fig 1.25. The RF is applied to the 50-Ω termination through a coaxial cable. It is necessary that a well defined impedance be available to absorb the transmitter power. The load must be capable of dissipating that power in the form of heat. So if the transmitter is capable of delivering, for example, 100 W, the 50-Ω load resistor must be capable of dissipating this power. The load must be a resistor that really appears as a resistor to

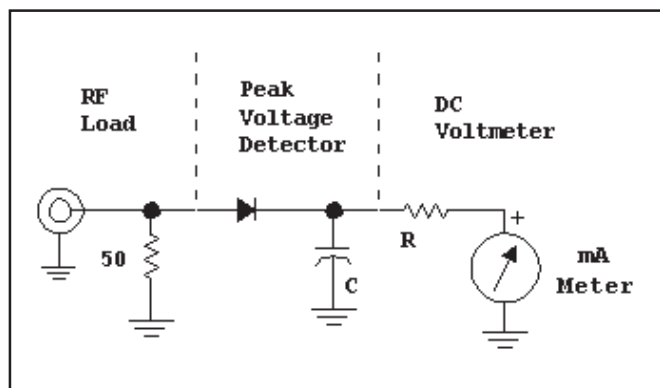

Fig 1.25—A basic RF power meter.

the radio frequency applied to it. This means that the usual power resistors sold by vendors, even if capable of dissipating 100 W, will not be suitable. They are usually built as a “wire wound” part, making them highly inductive for RF. It is sometimes possible to tune them, an interesting avenue for the advanced experimenter.

Suitable 50-Ω terminations, or “dummy loads” can be built with parallel combinations of 2-W carbon resistors, or similar 2 or 3-W metal oxide power resistors such as those manufactured by Yaeko or Xicon. Some of these are used in power attenuators described in Chapter 7.

The RF power dissipated in the resistor will develop a corresponding RF voltage. That is rectified with a simple diode detector, providing a signal across the capacitor equaling the peak RF voltage, less 0.7 V for the diode turn-on voltage.

The power meter is completed with a suitable dc volt meter. It can be as simple as a 0-1-mA current meter and a resistor, an FET voltmeter, or even a digital voltmeter.

**Fig 1.26** shows a dual range power meter. Essentially it is a pair of power meters sharing a single meter movement. The higher power part of the circuit starts with a 4-W load built from two parallel 100-Ω, 2-W resistors. These can be carbon or metal film resistors. If 2-W resistors are not available, four parallel 200-Ω 1-W parts will work as well. The resulting RF voltage is rectified with a silicon switching diode. This should be a 100-V part such as the 1N4148, 1N4152, or similar diode. The voltmeter part of the circuit is a 20-kΩ resistor driving a 0-1 mA meter.

Assume a transmitter is attached and keyed on to produce an indication of 0.6 mA. This represents a peak of 12 V, for the meter multiplier is the 20-kΩ resistor. The resulting power is then calculated from the formula given with the figure, 1613 mW, or 1.6 W.

The 50-mW input to the power meter uses a single 51-Ω, ¼-W, resistor with a more sensitive 1N34A rectifier diode. The meter multiplier is now just 1.5 kΩ. An approximate calibration curve is shown in **Fig 1.27**. The finished meter is shown in **Fig 1.28**.

Other schemes suitable for RF power measurement include terminated oscilloscopes, microwave power meters (usually using calorimeter measurement methods,) spectrum analyzers, and wideband logarithmic integrated circuits. Some of these will be covered in a later chapter.

Often we wish to examine an RF voltage to see if a circuit is “alive,” and perhaps to adjust it. The classic method for doing this used an RF probe with a high impedance, usually vacuum tube or FET voltmeter. The method is still very useful, especially when

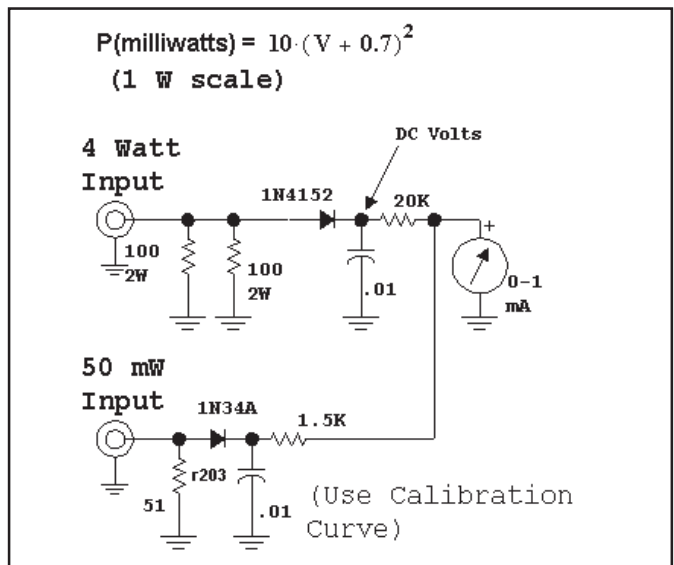

**Fig 1.26**—Dual range power meter. The 4-W input uses the formula to calculate power in milliwatts. The 50-mW range uses the curve of **Fig 1.23**.

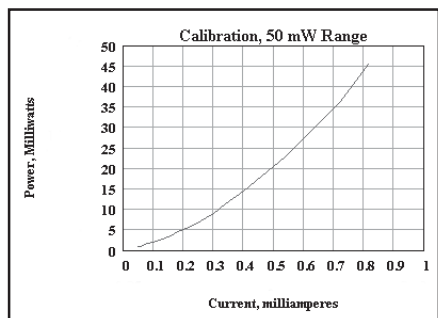

**Fig 1.27**—Calibration curve for the 50 mW range of the previous power meter.



**Fig 1.28**—The front panel of the dual-range QRP power meter.

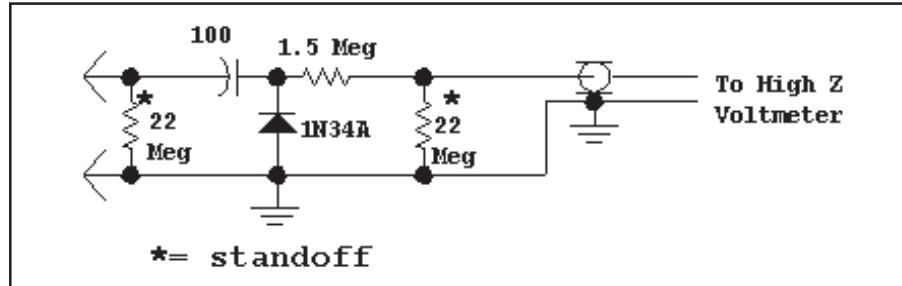

**Fig 1.29**—RF probe suitable for use with a VTVM, FET voltmeter, or even a DVM. Resistors marked with \* are standoff resistors used for probe construction and have little impact on circuit operation.

instrumentation is limited. **Fig 1.29** shows a very simple RF probe. The photo in **Fig 1.30** shows an open breadboard version; it’s the sort of circuit that one builds when a measurement must be done immediately. A long lasting version of the same circuit might better be built inside a cylinder at the end of the coaxial cable.

The probe may require calibration. This is best done with one of the other power

meters and a small transmitter or similar RF source. The transmitter is attached to the power meter and the output is measured. The corresponding RF voltage is noted and the RF probe is attached to the power meter 50-Ω resistor, producing a result that can be compared.

**Fig 1.31** shows a high impedance dc voltmeter suitable for use with this probe. It is also a good starting measurement tool for



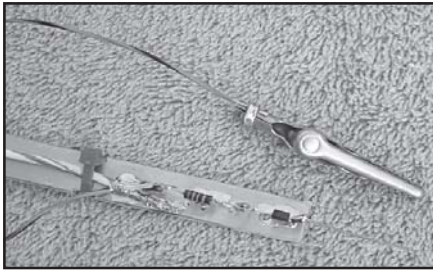

**Fig 1.30**—Close up view of an RF probe built on a strip of PC board material. The probe is a capacitor lead.

use in the lab. For general utility, it is useful to have the 5.1-M $\Omega$  resistor at the tip end of a probe that is inserted into a circuit for measurements. This allows the dc to be mea-

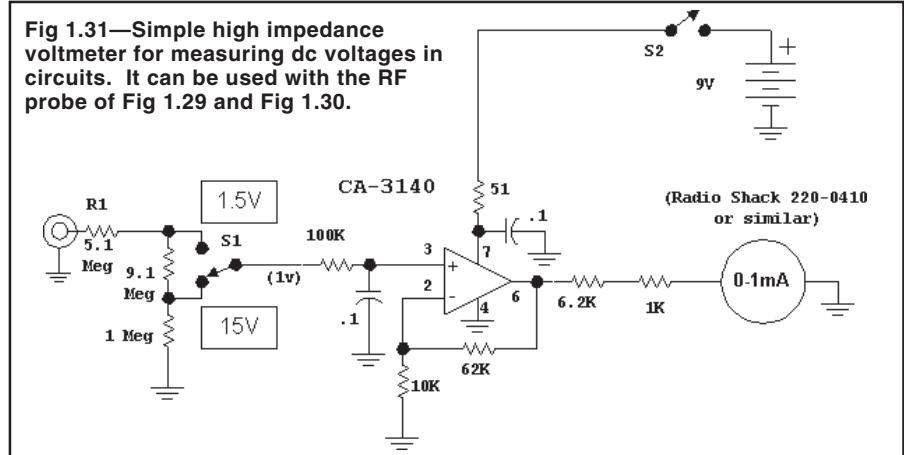

**Fig 1.31**—Simple high impedance voltmeter for measuring dc voltages in circuits. It can be used with the RF probe of Fig 1.29 and Fig 1.30.

sured without upsetting signals that may be present in the circuit. This circuit can be calibrated with a fresh 1.5-V battery; vary

the 6.2-k $\Omega$  resistor if needed. We will have more to say about RF power measurement in Chapter 7.

## 1.11 A FIRST TRANSMITTER

This section describes the design of a simple transmitter suitable as a first rig, a project for someone who has never built a transmitter. It uses robust circuits with few adjustments required during construction. It can be built with nothing more than a volt meter, a power meter, and power supply. We used an oscilloscope and a spectrum analyzer during the rig design phase and those results are presented. However, that equipment is not necessary for construction. The crystal controlled 2-W 40-meter transmitter is built with breadboard methods rather than with a printed circuit.

The circuit, shown in Fig 1.32, begins with Q1 functioning as a crystal controlled oscillator. Our crystal had a marked frequency of 7045 kHz. This was the specified frequency for operation with a 32-pF load capacitance. This Colpitts circuit uses a pair of series 390-pF feedback capacitors. The equivalent 195 pF parallels the crystal. Because this capacitance is much larger than the specified 32 pF, the operating frequency will be less than the marked 7045 kHz. If you want the frequency to be exact, a small trimmer capacitor can be placed in series with the crystal. We will eventually do this as a method of obtaining some slight tuning, but don't bother with this refinement in the beginning. The complexity of crystals is discussed in later chapters.

The oscillator is built on the end of a

scrap of circuit board material. The crystal was held on the board with a piece of double sided foam tape (Tesa, 67601). The oscillator worked right off with several V peak-to-peak observed at both the base and the emitter with an oscilloscope and 10X probe. The RF probe described earlier could also be used. The oscillator functioned well with supply voltages as low as 2.5 V. A quick check with a receiver confirmed the frequency.

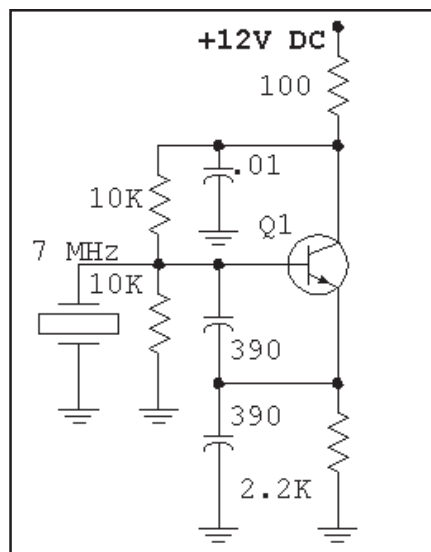

**Fig 1.32**—Crystal controlled oscillator that is the start of the beginner's transmitter.

The oscillator is followed by a buffer amplifier. A buffer is an amplifier that allows power to be extracted from an oscillator, or other stage, without adversely disturbing it. An ideal buffer often has a high input impedance so it can be attached without extracting any power. The best buffers have good reverse isolation, meaning that any signal present at the output is heavily attenuated at the input.

The first buffer tried was an emitter follower, a common choice to follow a crystal oscillator. Performance was poor. While the loading was light, the output was highly distorted. This problem behavior is discussed in detail in Chapter 2. The design was changed to the degenerated common emitter amplifier shown in Fig 1.33. We obtain the buffer input from the oscillator base instead of the more common emitter, for the waveform is cleaner, more sine-wave-like, at that point.

The buffer is added to the crystal oscillator by soldering the required parts to the board or to other components. The board is not installed in a box at this time. Rather, it's loose where it is easiest to build and measure. We can tack solder small load resistors or coax connectors to the board to facilitate experimentation.

The buffer output transformer has a 4:1 turns ratio. The primary, the 12-turn winding on a FB43-2401 ferrite bead, or a FT37-43 toroid, which is virtually identical, has an inductance of about 50  $\mu$ H. This

has a 7-MHz reactance of 2.3-k $\Omega$ . The load on the output is transformed from 50  $\Omega$  up by the square of the turns ratio to 800  $\Omega$ , the approximate impedance presented to the collector of Q2. The inductive reactance is much higher, so it does not impact the circuit operation. The output is not tuned, allowing it to function well over a wide frequency range.

We measured the power from the 3-turn output link on T1 by attaching a small length of coax cable that ran to the 50-mW input of the power meter described earlier. The output was +10 dBm, 10 mW, with R1=270  $\Omega$ , and was up to +15 dBm with R1 of 150  $\Omega$ . Recall that the power meter has a 50- $\Omega$  impedance.

We want more than 10 mW from our transmitter and will eventually add a power amplifier to reach an output of two

W. That amplifier will require modest drive of 200 to 300 mW. We could obtain more power by biasing the second stage for higher gain and output. A more conservative and stable, free from self-oscillation, approach adds a third stage.

The evolving design is shown in Fig 1.34 with a class C amplifier for Q3. We want this third stage to provide a power gain of 10 and pick another 2N3904. With an F<sub>t</sub> more than ten times the operating frequency, gain will be good. The 2N3904 also has a beta that holds up well at high currents, a useful characteristic for a power amplifier. While we wanted class C operation in the 3<sup>rd</sup> stage, stability was deemed vital, so the circuit is degenerated with a 10- $\Omega$  emitter resistor and a 100- $\Omega$  load is placed at the base. Class C operation is

assured. Q3 current disappears when RF drive is removed from the amplifier.

The desired driver output power is 1/3 W. This can be realized by properly loading the stage. We must present a resistive load to the collector given by

$$R_L = \frac{(V_{CC} - V_e)^2}{2 \cdot P_{out}} \quad (\text{Eq. 1.2})$$

where V<sub>cc</sub> is the supply, V<sub>e</sub> is the emitter voltage, and R<sub>L</sub> is the load resistance in Ohms. (V<sub>cc</sub>-V<sub>e</sub>) is about 11 V for this example, so the equation predicts a desired load of about 150  $\Omega$ . An L-network, L1 and the 200-pF capacitor, is designed to transform a 50- $\Omega$  load to “look like” 200  $\Omega$  at the collector. An RF choke provides collector bias for the transistor. While tunable components could have been used in the L-network to get the optimum output, we elected to use fixed values. The L-network design (see section 3.6) produced values of 1.97  $\mu$ H and 197 pF. We wound an inductor on a toroid and then measured inductance, spreading or compressing turns slightly to produce the desired value. We then used a 5% value for the 200-pF capacitor. Variable elements are only needed in higher Q situations, or where it is not possible to find tight tolerance components.

Power output could be measured with the 4-W position of the watt meter. We used an alternative approach here. A 51- $\Omega$  1/2-W resistor was tack soldered into the circuit at the output point shown in Fig 1.34 and the output voltage was measured with an oscilloscope and 10X probe. The Q3 output was 123 mW, 7 V peak-to-peak at the load, with R1=270  $\Omega$  in the buffer. Changing R1 to 150  $\Omega$  increased output to 314 mW. The DC current, 43 mA, was determined by measuring the voltage drop across the 10- $\Omega$  decoupling resistor. The calculated efficiency is then 62%, good for an amplifier which contains resistors in both the emitter and collector. The 2N3904 at Q3 is operating well within ratings. Generally, a TO-92 plastic transistor like the 2N3904 can dissipate a quarter of a watt for extended times, or half a watt for the shorter intermittent periods encountered in a CW transmitter. This “rule of thumb” can be stretched with heat-sinking, or easily violated in thermally isolated settings. Owing to the good efficiency, the dissipation is only 200 mW in Q3.

Q3 power output varied smoothly from very low levels up to the maximum 314 mW as V<sub>cc</sub> was adjusted from 5 to 12 V. This is generally a useful method for ex-

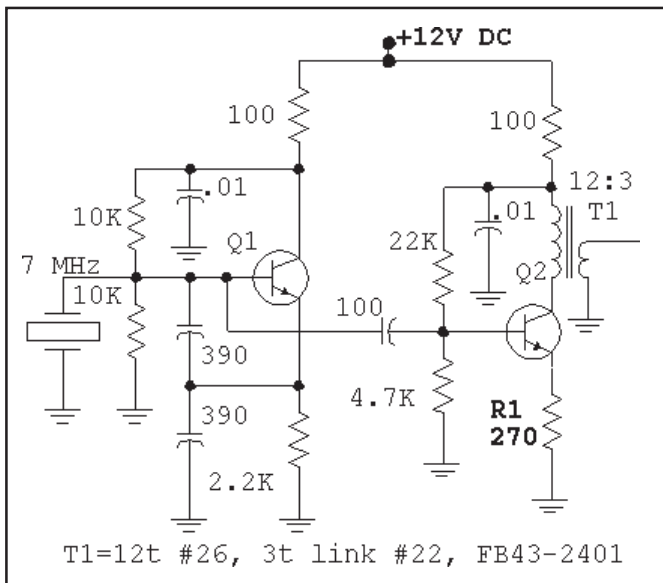

Fig 1.33—Evolving transmitter schematic showing the addition of a buffer amplifier, Q2.

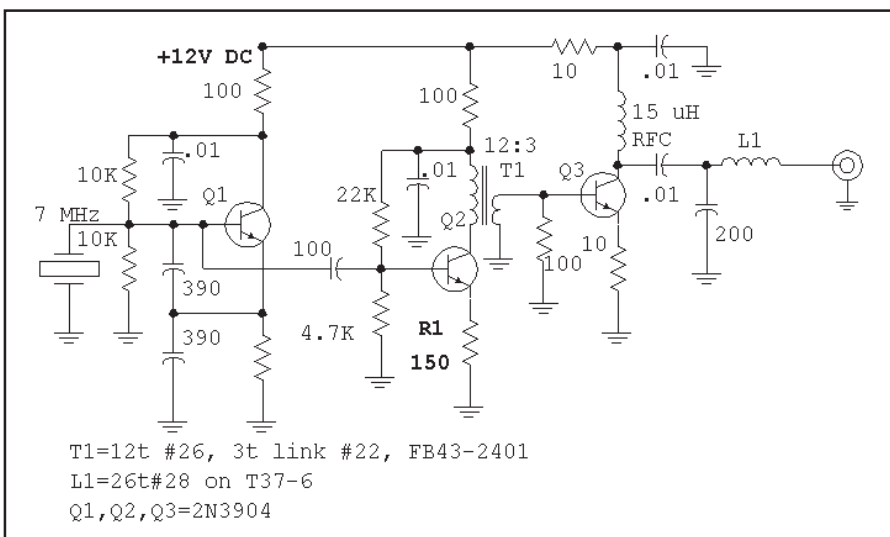

Fig 1.34—A Class C driver amplifier, Q3, is added to the transmitter.

aming stability. We will eventually add a “drive control” to the circuit.

Before continuing we need to address the issue of spectral purity. Some observed waveforms have departed from a sine wave. This means that these waveforms are harmonic-rich. This transmitter uses a crystal oscillator operating at the output frequency. The only signals that should be present anywhere within the transmitter are at 7 MHz or harmonics at 14, 21,

28, ... MHz. The only filtering needed is a low pass filter at the transmitter output. While the L-network that makes a 50- $\Omega$  load appear as 200  $\Omega$  at the Q3 collector has a low pass characteristic, it has only two components and is not very effective as a filter. If the driver amplifier is going to be used by itself as a transmitter, another low pass filter should be added to the output. There is, however, little value in adding a better low pass filter

after the driver if it is to be used only to drive another stage which will also be creating harmonic distortion. Spectrum analyzer measurements showed spurious driver outputs at -27, -30, -43, and -49 dBc for the second through fifth harmonics when the driver was delivering full output. The harmonic suppression was actually worse at lower output levels. The term dBc refers to dB down with respect to the *carrier*.

## 1.12 A BIPOLAR TRANSISTOR POWER AMPLIFIER

The project now starts to get exciting as we begin to experiment with higher output powers. The transistor we have selected for a 2-W power amplifier (PA) is a 2N5321. This is a NPN device in a TO-39 case with a collector dissipation of 10 W in an infinite head sink, or 1 W in free air, 50-V breakdowns, the ability to switch a current of 2 A, and a 50-MHz  $F_T$ , all for less than \$1. The low  $F_T$  restricts the device to the lower bands, but it also means that high frequency stability will not be an issue. The 2-W PA schematic is presented in Fig 1.35.

The first detail we must consider with the PA is a heat sink. Our intention was to increase power by about 10 dB to the 2 to 3-W level. If efficiency turns out to be 50%, we will have a collector dissipation that is the same as the RF output. The transistor can't support this power without a heat sink. We had a Thermalloy 2215A in the junk box which should be more than adequate. The transistor was mounted in the heat sink which was then bolted to a PC board scrap. Holes through the board made the leads available for soldering. Be careful to avoid any short circuits that are not intended. The transistor case is attached to

the collector terminal in most TO-39 packaged devices.

It's always difficult to estimate heat sink sizes. While one can do thermodynamic calculations, it's generally adequate with small transmitters to experimentally treat the problem. Touch the heat sink often during initial measurements. If it's too hot to touch, the heat sink is not large enough. We always seem to err in the conservative area with more heat sink than is needed.

The formula presented in Eq 1.2 shows that a 25- $\Omega$  load resistance presented to the collector will support the desired output. A simple pi-network was designed. The network Q was kept low, but was picked to generate a network with standard, and junk-box available, capacitors. A matching network design is presented in Chapter 3.

A 33-V Zener diode is attached from the collector to ground. The collector voltage will never reach these levels with normal Class-C operation, so the diode is transparent except for the sometimes substantial capacitance that it adds to the collector circuit. But, the diode conducts if the output load disappears, and prevents collector breakdown that might otherwise destroy

the transistor. Care was taken to keep the emitter lead short when the amplifier was built, for even small amounts of inductance can alter the performance. This is *not always* bad.

Transmitter testing *always* begins by attaching a 50- $\Omega$  load to the output. This can be a power meter or a resistor of the proper rating. The PA should never be run without a load.

The first PA we built for this project used the simplified circuit of Fig 1.36. This circuit suffered from instabilities which became clear as we varied the drive from the earlier part of the transmitter. At one point, the RF output and the collector current both changed abruptly. The oscilloscope showed frequencies well below the desired 7 MHz. Changing the collector RF choke from the original 15  $\mu$ H to a smaller 2.7- $\mu$ H molded choke moved the frequency up, but the instability was still present. However, changing the base circuit to one with a lower drive impedance completely solved the problem. The output power and collector current now vary smoothly as the drive is varied. The base transformer is a 2:1 turns ratio step-down that now drives the base from a

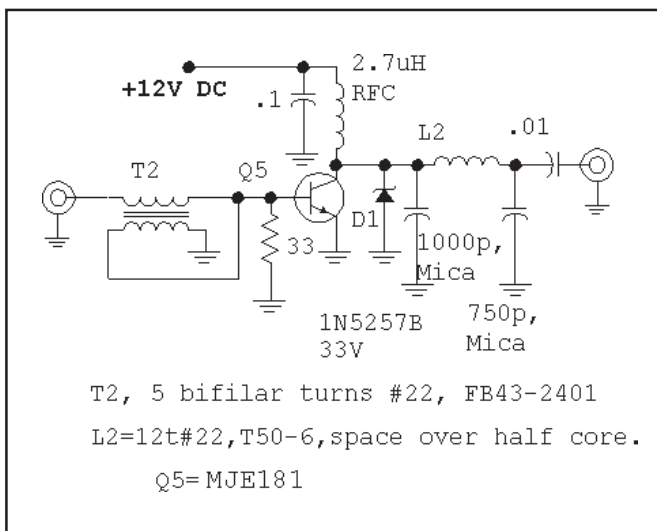

Fig 1.35—A 2 W power amplifier.

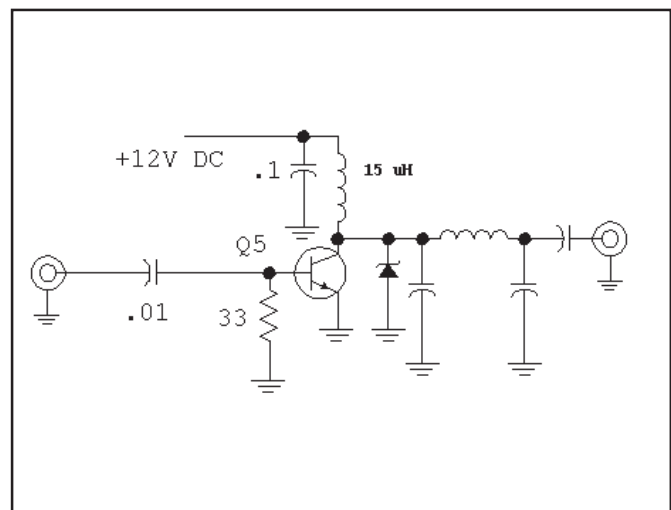

Fig 1.36—Earlier simplified PA design which suffered with stability problems. See text for discussion.

12.5- $\Omega$  source impedance. The 33- $\Omega$  base resistor absorbs some drive and tends to stabilize the amplifier. Changing this resistor is one of the experimental “hooks” available to the experimenter fighting instability.

The 2-W amplifier is installed in the transmitter. An output power of 2.25 W results from a drive of just over 100 mW. Increasing the drive produces higher out-

put. But once the output gets much beyond 3 W, Q5 begins to heat. Although a higher power was observed with the oscilloscope when the key was first pressed, the power decreases over a period of a few seconds before stabilizing. We investigated this by looking at the collector waveform at differing drive levels. When driven to 2.25-W output, the collector voltage varied between 3 and 23 V. As drive

increases, the bottom of the collector swing drops toward zero. But at this point the amplifier is fully loaded. Further excursions are not consistent with simple class C operation. More drive will cause higher current with little increases in output, allowing efficiency to decrease. This causes the heating. Changing both the matching network and drive power is needed for higher output.

## 1.13 AN OUTPUT LOW PASS FILTER

When the 2-W amplifier drive is adjusted for 2.25-W output, the measured efficiency was 47%. A spectrum analysis showed 2<sup>nd</sup> and 3<sup>rd</sup> harmonics at -36 dBc and -47 dBc. Addition of an outboard low pass filter removed all spurious responses to better than -75 dBc.

The outboard low pass filter is shown in Fig 1.37. This is a 7<sup>th</sup>-order Chebyshev design with a 7.5-MHz ripple cutoff frequency and a ripple of .07 dB. The rather obscure ripple was picked to fit standard value capacitors that were on hand. The inner capacitors are parallel combinations of 680 and 180 pF. The measured insertion loss for the filter was 0.11 dB at 7 MHz. The filter was built into a small aluminum box, Fig 1.38, as an outboard appendage so it could be used for other projects. Also, the performance is superior when the shielding around the filter is absolute. If the same filter was built into the transmitter, there is a greater chance that ground currents and radiation could provide paths for signals to leak around the filter.

This extreme filtering is probably redundant. A much simpler filter could be built into the transmitter, near the output

coax connector, for adequate harmonic attenuation. Chapter 3 provides detail.

### Practical Details

The modules built so far are mere scraps of circuit board material sitting on a bench with short pieces of wire to tie them together. They need to be refined and packaged to create a transmitter that we can put on the air. An almost complete schematic of the transmitter is shown in Fig 1.39.

The first refinement is a keying circuit. This function is performed by Q4, a PNP switching *integrator*. This is a favorite keying scheme of ours, allowing a grounded key to control the positive supply to a transmitter stage. Keying in the positive supply allows the grounded parts of the circuit to remain grounded without ever being disturbed by keying. Q4 serves the additional function of shaping the keying. When the key is pressed, current begins to flow in the 3.9-k $\Omega$  resistor. The current flows from Q4 base which “tries” to turn Q4 on. As the Q4 collector voltage begins to increase, the change is coupled back to the base through the capacitor. The

positive going signal opposes the current extracted by the 3.9-k $\Omega$  resistor. Hence, the collector does not switch immediately to a high state. Rather, it ramps upward at an approximately steady rate until Q4 becomes saturated. Forcing the stage to turn on smoothly over a couple of milliseconds restricts the bandwidth of the modulation related to turning the carrier on. That bandwidth will extend a few hundred Hz on either side of the carrier. Beyond that, no clicks will be heard in a good receiver.

A power output control is added to the emitter of Q2. Owing to the class C nature of the following amplifiers, the output control will allow the transmitter to run from the maximum output down to virtually nothing. The control is a screwdriver adjusted pot mounted on the board.

A variable capacitor, C1, is added to the crystal oscillator. The capacitor used in our transmitter tuned from 5 to 80 pF and provided a tuning range of 3 to 4 kHz. Use whatever is in your junkbox. While certainly not a substitute for a VFO, it allows the user to dodge some interference. A “spot” switch, S2, allows the oscillator to function without placing a signal on the air.

Finally, a transmit-receive system is added. This function is performed with a multi-pole toggle switch, a simple but ad-

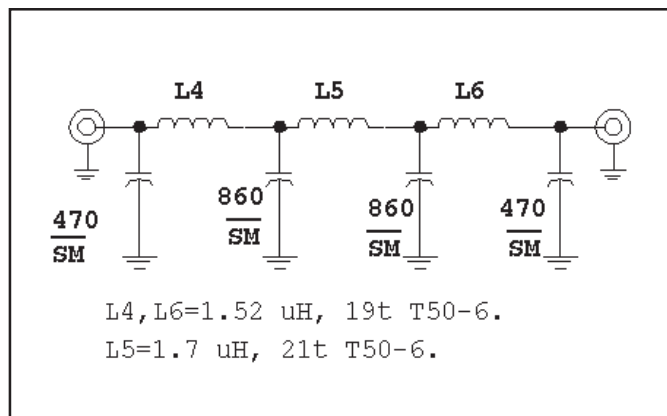

Fig 1.37—Low pass filter for use with the experimental transmitter.

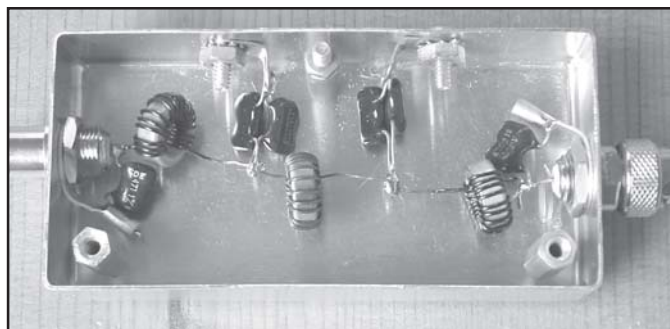

Fig 1.38—Inside view of the 7-element low pass filter built to go with the beginner’s rig. The filter is also used with other equipment.

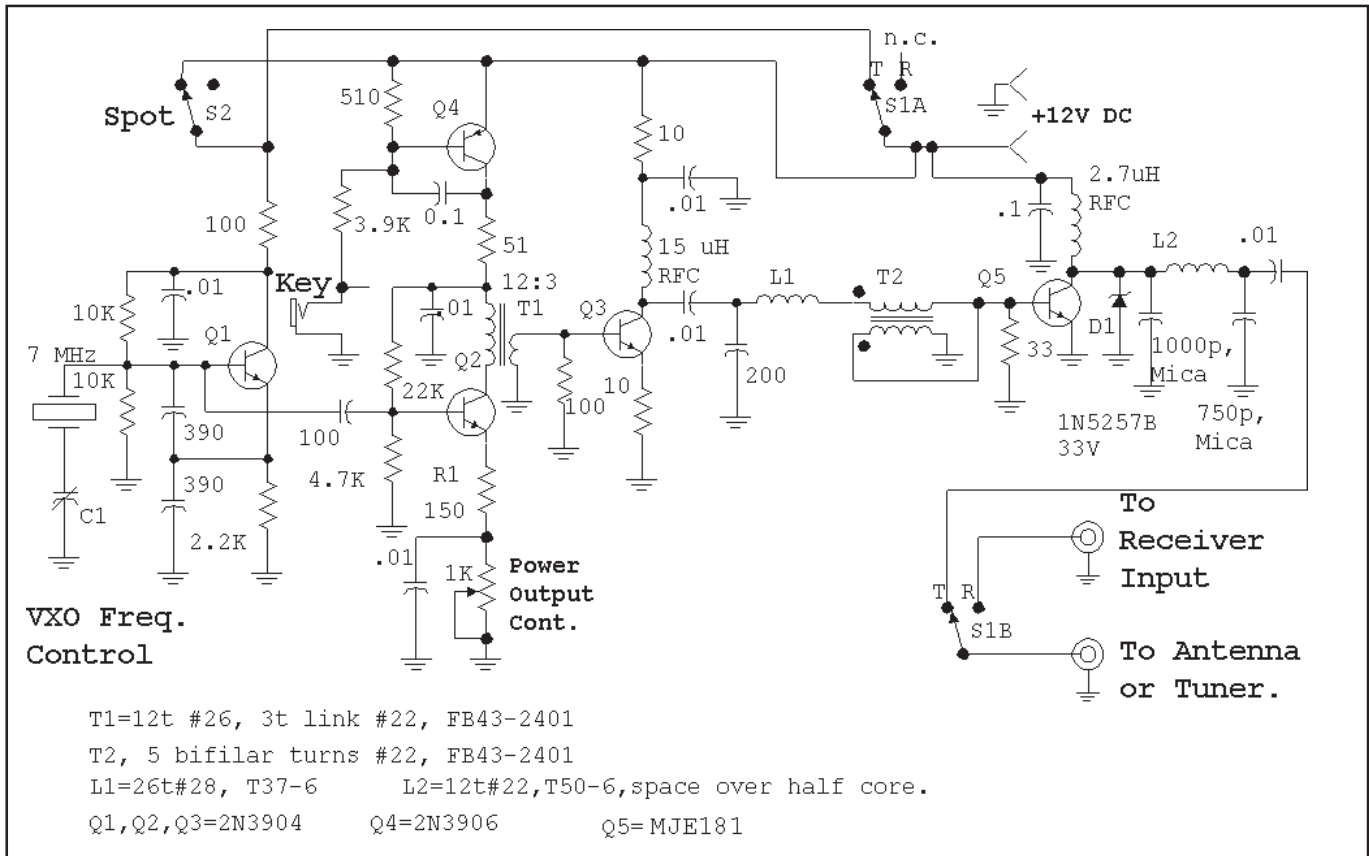

Fig 1.39—A nearly complete schematic of the transmitter. This version combines the PA with the earlier stages, adds shaped keying, power output adjust, T/R switching, and VXO action.

equate solution. S1A applies the +12 V supply to the oscillator during transmit periods. The supply is always available to Q3 and Q5 and does not need to be switched. The keying circuit, Q4, controls

the supply reaching Q2. S1B switches the antenna from the receiver to the transmitter. The miniature toggle switch at S1 is suitable for powers up through a few watts. More refined T/R methods are presented

elsewhere in the book.

If this transmitter is to be used with a high quality modern receiver with a wide AGC range, a two pole switch is all that is needed at S1. The user can then listen to the transmitter in the receiver as the key is actuated. The more common scenario places this transmitter with a simple direct conversion receiver such as that described earlier in this chapter. It will then be impossible to turn the gain in that receiver down far enough to prevent overload. An answer to the problem is presented in Fig 1.40 where a sidetone oscillator is added to the system. A 555-timer integrated circuit functions as the square wave oscillator which is keyed on and off with Q5. Q5 base current routes through a 10-kΩ resistor attached to the key in Fig 1.39. R2 must be adjusted for the headphones used with the transmitter. The headphones are disconnected from the receiver during transmit intervals, attached only to the sidetone oscillator. Two phone jacks are included on the transmitter. A short cable then routes the receiver audio output from the receiver to the transmitter where it is switched. This scheme does not prevent the receiver from being overloaded, but guarantees that you don't have to listen when it happens. The receiver won't be damaged by

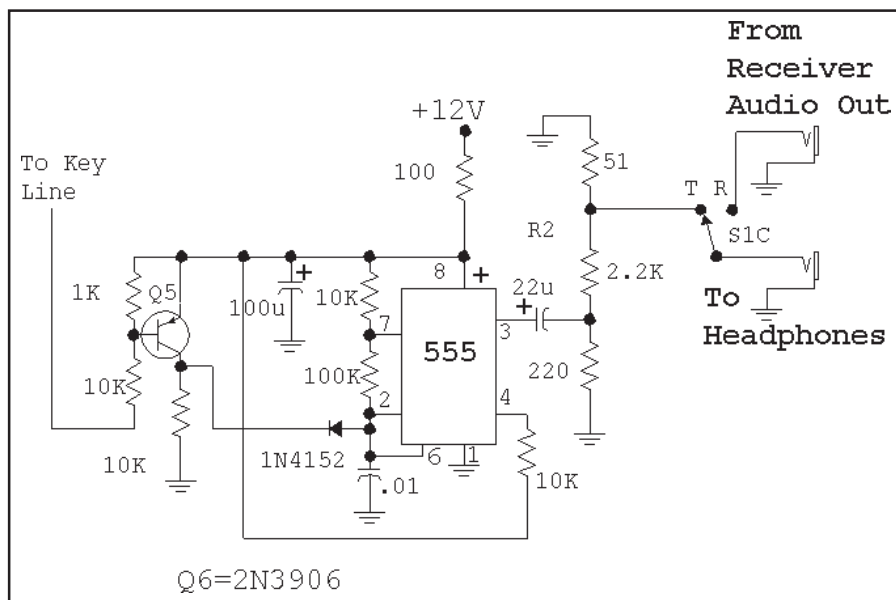
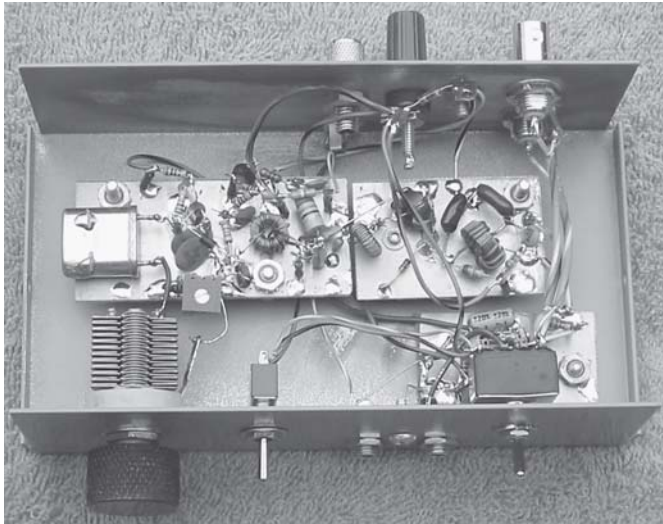

Fig 1.40—Sidetone oscillator for the transmitter. This circuit is also suitable as a code practice oscillator.



**Fig 1.41—Overall view of the complete transmitter construction.**



**Fig 1.42—Outside view of the Beginner Station. At left is the beginner's direct conversion receiver with the transmitter at the right.**

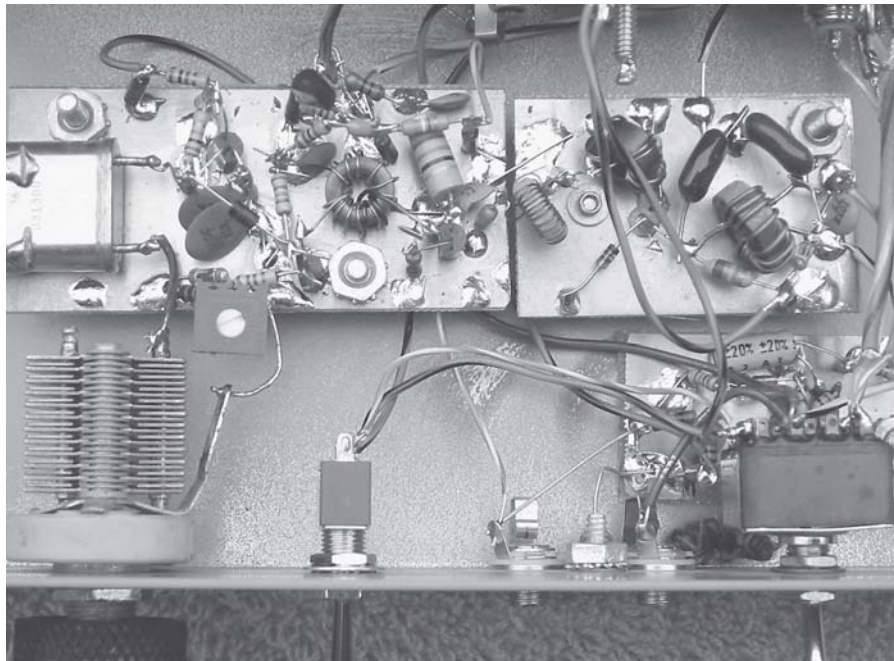

**Fig 1.43—The inside view of the transmitter shows the capacitor and T/R switch mounted to the front panel with power and coaxial connectors on the rear. The left board contains the first three stages while the right board contains the 2-W power amplifier. A heat sink is under that board. A small board under the T/R switch contains the sidetone oscillator.**

the overload. A third pole is needed on the switch for this refinement. Three pole double throw toggle switches are unusual, so we used one with four poles.

The complete transmitter is packaged in a standard box as shown in **Fig 1.41**. This one measured 2 x 3.5 x 6 inches, although whatever is available will work. Alternatively, you can build your own box. The outside of the box can be fixed to be as attractive as you would like it to be, consistent with personal tastes. The variable capacitor, C1, the spotting switch, S2, and the T/R switch are located on the front panel as shown on the right hand side of **Fig 1.42**. The key jack and a headphone jack are also located on the front. The rear panel contains power receptacles, a jack for the audio input from the receiver, and coaxial connectors for the antenna and a cable to the receiver input. The box we purchased for the transmitter had gray paint on it. Unfortunately, it had nearly as much paint on the inside as was on the outside. Inside paint was removed where components were grounded to the case. Details of the internal construction appear in **Fig 1.43**.

## 1.14 ABOUT THE SCHEMATICS IN THIS BOOK

The schematic diagrams used in this book differ slightly from other ARRL publications in that we use slightly different conventions. Not all details are presented in all schematics.

Capacitors are in microfarads if electrolytic or if they have decimal values less than 1. Values greater than unity are in picofarad if they are not electrolytic. Electrolytic caps always have a voltage rating greater than the  $V_{cc}$  or  $V_{dd}$  value used

in the circuit with 25 V being typical. In some applications we will use C values in nF, which stands for nanofarad.  $1000 \text{ pF} = 1 \text{ nF}$ .

RF transformers are specified by turns ratio rather than impedance ratio. Often this data is presented within the schematic diagram rather than as part of a caption. The same holds for inductance values. We strive to load the schematic with as much information as possible.

We generally label schematics with the parts that we used. But that does not mean that this is what you might want to use. An example is our frequent use the 1N4152 silicon switching diode. In all cases, virtually all of these can be replaced by the more common 1N4148 or 1N914. When there is a question about such details, look the part up and see if the parts you have on hand are similar. Then try the substitution.

## REFERENCES

1. W. Hayward and D. DeMaw, *Solid State Design for the Radio Amateur*, ARRL, 1977.
2. R. Hayward and W. Hayward, "The Ugly Weekender," *QST*, Aug, 1981, pp 18-21. See also G. Grammer, *Understanding Amateur Radio*, ARRL, 2<sup>nd</sup> Edition, 1976, p 144.
3. R. Lewallen, "An Optimized QRP Transceiver," *QST*, Aug, 1980, pp 14-19.
4. J. Dillon, "The Neophyte Receiver," *QST*, Feb, 1988, p 14-18.
5. C. Kitchin, "A Simple Regenerative Radio for Beginners," *QST*, Sep, 2000, p 61.
6. C. Kitchin, "An Ultra-Simple VHF Receiver for 6 Meters," *QST*, Dec, 1997, p 39.
7. G. Dobbs, "A Stable Regenerative Receiver," *SPRAT*, Issue 105, Dec, 2000, p 21.

